

Components for safety applications

Preventa safety modules
for emergency stop, limit switch and two-hand control monitoring

Operating principle, characteristics

Operating principle (see page 1/12)

Characteristics

Type		XPS-AS	XPS-AM	XPS-AP
Product designed for use in safety related parts of control systems (conforming to EN 954-1)		Category 4		
Supply - voltage - voltage limits	V	\sim and \equiv 24 or 48, \sim 115, \sim 230 \sim - 20...+ 10 % (24 V, 48 V) \equiv - 20...+ 20 % (24 V, 48 V) \sim - 15...+ 15 % (115 V) \sim - 15...+ 10 % (230 V)		
- frequency	Hz	50/60		
Consumption 24 V 48 V 115 V/230 V	VA	< 6 < 9 < 6	< 6 < 9 < 7	< 8 < 11 < 8
Module fuse protection		Internal, electronic		
Control unit voltage between S11-S12, S21-S22 or S11-B1	V	24 (24 V version), 48 (48 V, 115 V, 230 V versions)		
Minimum voltage and current between terminals S11-S12, S21-S22 or S11-B1 (inputs A and B) U min./I min. - 24 V (20 °C) version U min./I min. - 48 V (20 °C) version U min./I min. - 115 V/230 V (20° C) vers.		16 V/70 mA 35 V/25 mA 41 V/25 mA	16 V/60 mA 35 V/25 mA 41 V/25 mA	16 V/100 mA 35 V/45 mA 41 V/45 mA
Calculation of wiring resistance RL between terminals S11-S12, S21-S22 or S11-B1 as a function of the internal supply voltage U int (terminals S11-S21)	Ω	$RL \max. = \frac{U \text{ int} - U \text{ min.}}{I \text{ min.}}$ Ue = true voltage applied to terminals A1-A2 U int = supply voltage Ue - 3 V (24 V, 48 V version) U int between 42 V and 45 V, with typical value = 45 V (115 V, 230 V version) RL max. must not exceed 50 Ω		
Synchronisation time between inputs A and B automatic start, linked terminals S33-S34	ms	Approx. 300		
Outputs - voltage reference - number and type of safety circuits		Volt-free		
		2 N/O (13-14, 23-24)	3 N/O (13-14, 23-24, 33-34)	6 N/O (13-14, 23-24, 33-34, 43-44, 53-54, 63-64)
- number and type of additional circuits		–	1 N/C (41-42)	1 N/C (71-72)
- breaking capacity in AC-15	VA	C300 : inrush 1800, maintained 180 24 V/1.5 A - L/R = 50 ms		
- breaking capacity in DC-13				
- max. thermal current (Ithe)	A	5	6	
- output fuse protection conforming to IEC 947-5-1, DIN VDE 0660 part 200	A	6 fast acting, 4 gl		
- minimum current	mA	10		
- minimum voltage	V	17		
- max. total thermal current	A	10	15	30
Electrical life		See page 1/10		
Response time on input opening	ms	< 40		
Rated insulation voltage (Ui)	V	300 (degree of pollution 2 conforming to IEC 947-5-1, DIN VDE 0110 parts 1 and 2)		
Rated impulse withstand voltage (Uimp)	kV	4 (overvoltage category III, conforming to IEC 947-1, DIN VDE 0110 parts 1 and 2)		
LED display		4		
Operating temperature	°C	- 10...+ 55		
Storage temperature	°C	- 25...+ 85		
Degree of protection	Terminals	IP 20		
conforming to IEC 529	Enclosure	IP 40		
Connection	Type	Captive screw clamp terminals : without cable end 1 x 4 mm ² , with cable end 2 x 2.5 mm ²		

Components for safety applications

Preventa safety modules
for emergency stop, limit switch and two-hand control monitoring

References

References

Description	No. of safety circuits	Additional outputs	Supply	Reference	Weight kg
Safety modules for emergency stop, limit switch and two-hand control monitoring	2	-	~ and = 24 V	XPS-AS5140	0.350
			~ and = 48 V	XPS-AS5340	0.350
			~ 115 V	XPS-AS3440	0.450
			~ 230 V	XPS-AS3740	0.450
	3	1 (NC)	~ and = 24 V	XPS-AM5140	0.600
			~ and = 48 V	XPS-AM5340	0.600
			~ 115 V	XPS-AM3440	0.700
			~ 230 V	XPS-AM3740	0.700
	6	1 (NC)	~ and = 24 V	XPS-AP5140	0.600
			~ and = 48 V	XPS-AP5340	0.600
			~ 115 V	XPS-AP3440	0.700
			~ 230 V	XPS-AP3740	0.700



XPS-AS



XPS-AM

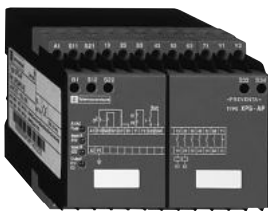

XPS-AP

Components for safety applications

Preventa safety modules
for emergency stop, limit switch and two-hand control monitoring

Connections, functional diagrams

XPS-AS

Module XPS-AS associated with an emergency stop button with 2 N/C contacts

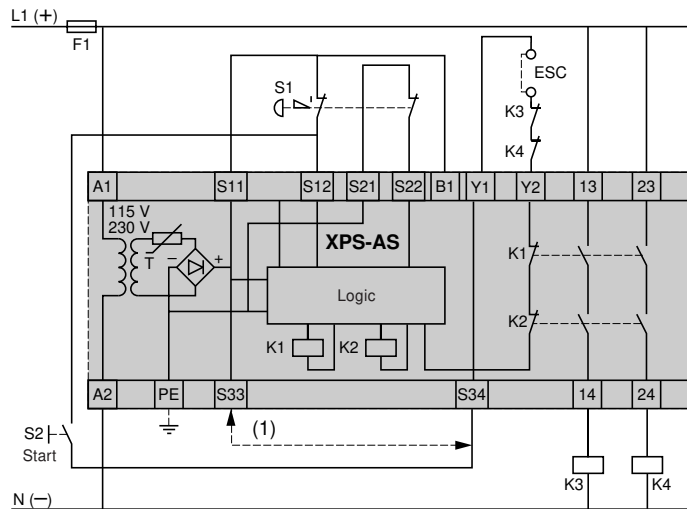

ESC : External start conditions
Y1-Y2 : Feedback loop
(1) Automatic start

Key to LEDs

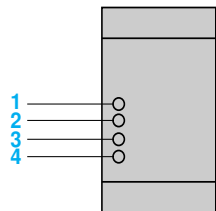

- 1 A1-A2 supply voltage, fuse status
- 2 Input S12 (A)
- 3 Input S22 (B)
- 4 K1/K2 status (N/O safety outputs off)

Type III A two-hand control monitoring conforming to EN 574

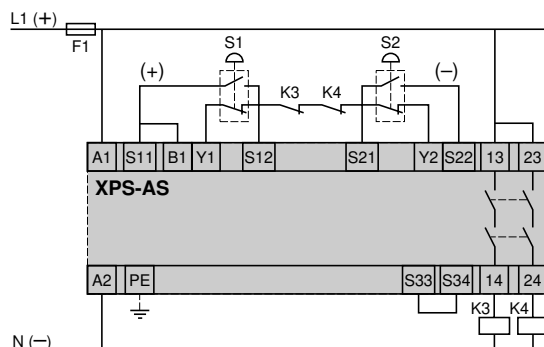

S1 and S2 : pushbuttons.
Must not be used for applications (presses) which require a type III C module (XPS-BC) conforming to EN 574

Functional diagrams
Emergency stop function

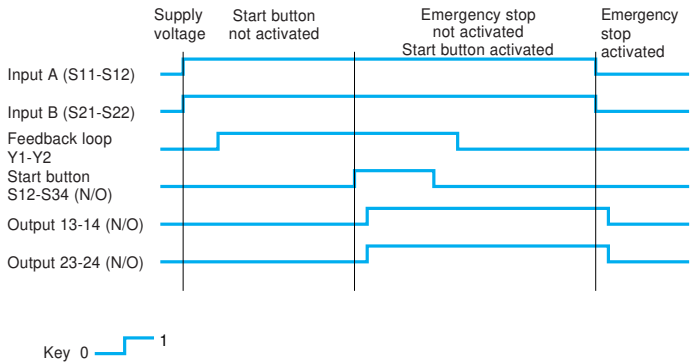

Guard with automatic start function

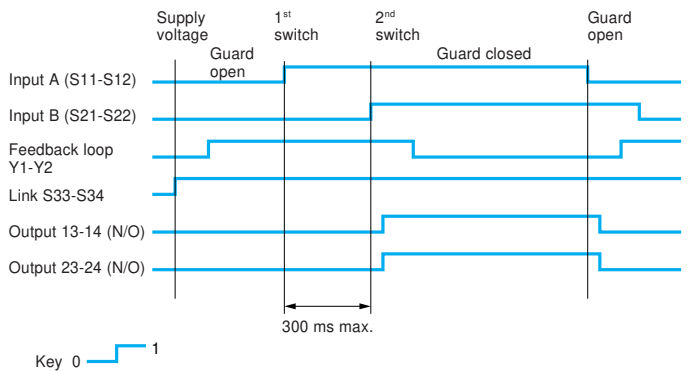

Two-hand control function

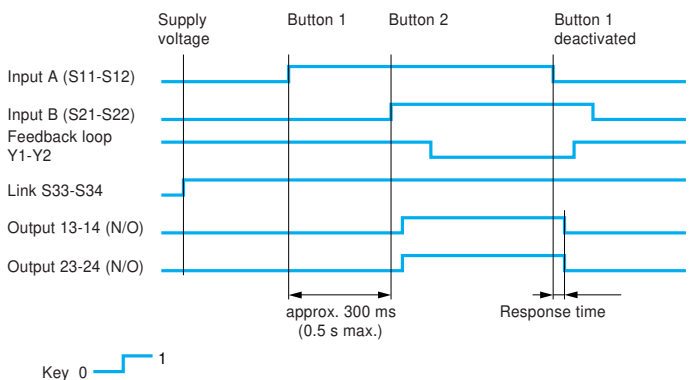

Components for safety applications

Preventa safety modules
for emergency stop, limit switch and two-hand control monitoring

Connections, functional diagrams

XPS-AM

Module XPS-AM associated with an emergency stop button with 2 N/C contacts

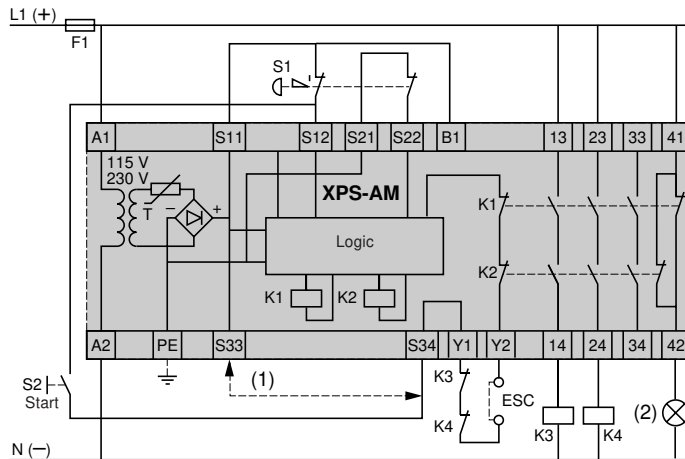

- (1) Automatic start
- (2) "Emergency stop" signalling
- ESC : External start conditions
- Y1-Y2 : Feedback loop

Key to LEDs

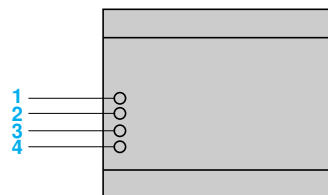

- 1 A1-A2 supply voltage, fuse status
- 2 Input S12 (A)
- 3 Input S22 (B)
- 4 K1/K2 status (N/O safety outputs closed)

Functional diagrams Emergency stop function

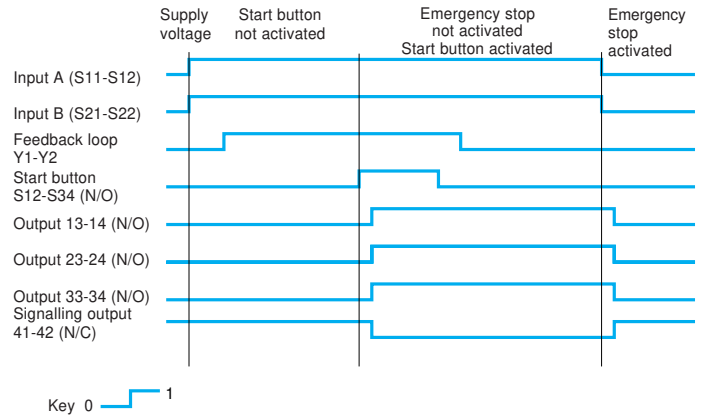

Guard with automatic start function

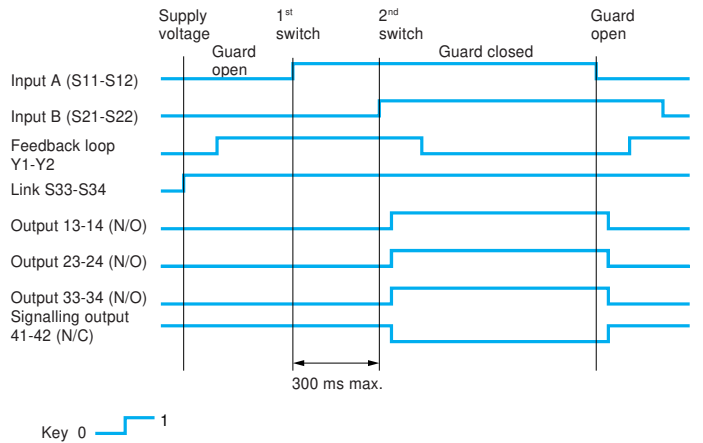

Components for safety applications

Preventa safety modules
for emergency stop, limit switch and two-hand control monitoring

Connections, functional diagrams

1

XPS-AP

Module XPS-AP associated with an emergency stop button with 2 N/C contacts

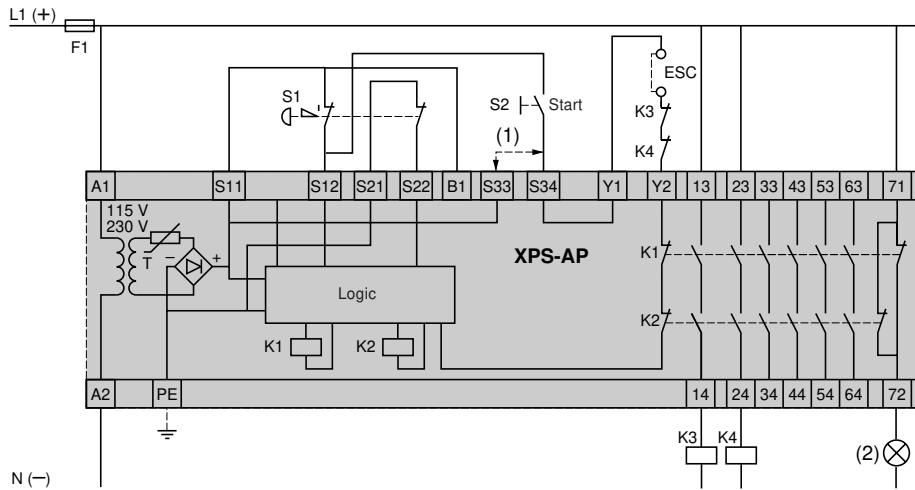

- (1) Automatic start
- (2) "Emergency stop" signalling
- ESC : External start conditions
- Y1-Y2 : Feedback loop

Key to LEDs

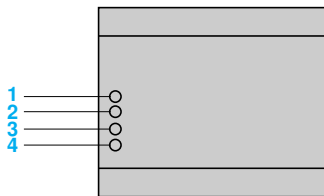

- 1 A1-A2 supply voltage, fuse status
- 2 Input S12 (A)
- 3 Input S22 (B)
- 4 K1/K2 status (N/O safety outputs closed)

Functional diagrams

Emergency stop function

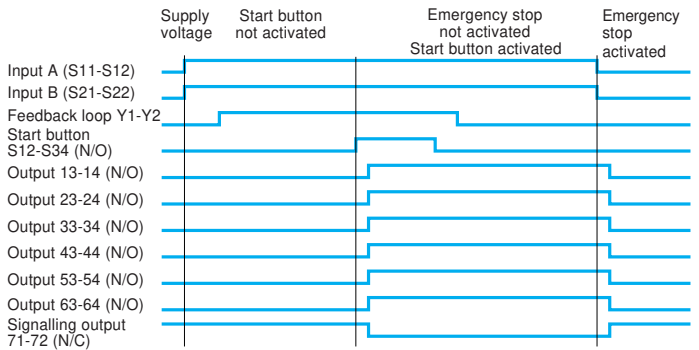

Key 0 1

Guard with automatic start function

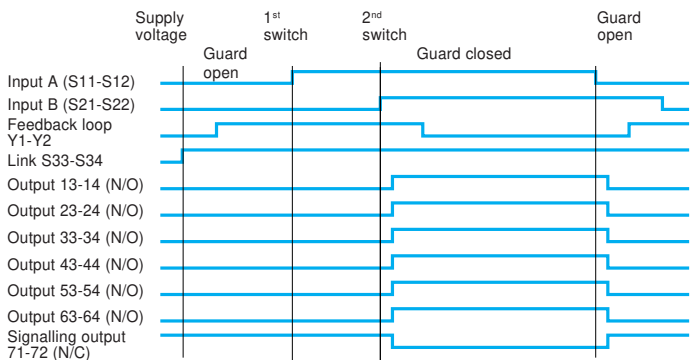

Key 0 1

Components for safety applications

Preventa safety modules
for emergency stop, limit switch and two-hand control monitoring

Connections

XPS-AS/AM/AP

Emergency stop monitoring configuration
1-channel wiring

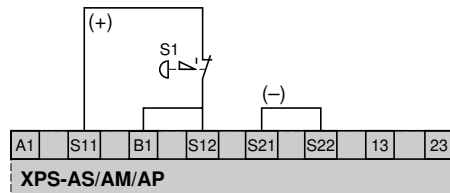

Emergency stop button with 1 N/C contact.
Not all faults are detected : a short-circuit on the emergency stop button is not detected.

2-channel wiring

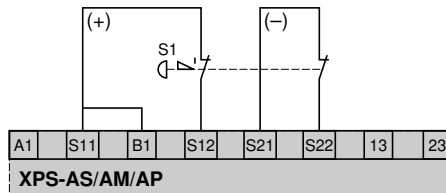

Emergency stop button with 2 N/C contacts (recommended application).
The 2 input channels are connected to different polarities. A short-circuit between the 2 inputs is detected.

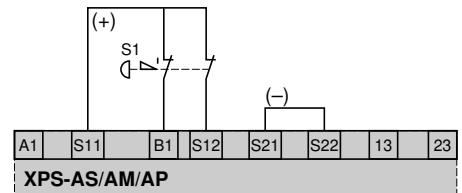

Emergency stop button with 2 N/C contacts.
Both input channels are connected to the same polarity. A short-circuit between the 2 inputs is not detected.

2-channel wiring

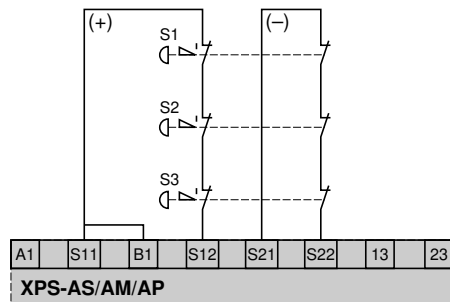

Connection to multiple emergency stop buttons with 2 N/C contacts (recommended application).
The 2 input channels are connected to different polarities. A short-circuit between the 2 inputs is detected.
NOTE : A high resistance short between channels may not be detected.

Type III A two-hand control monitoring, conforming to EN 574

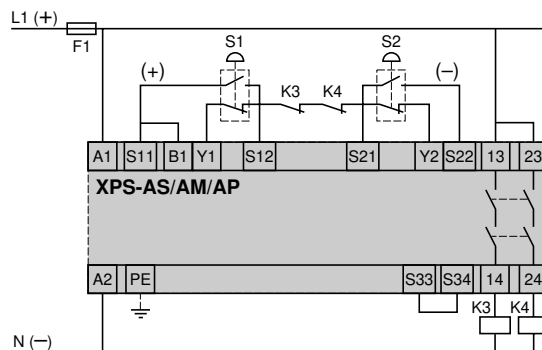

S1 and S2 : pushbuttons.
Must not be used for applications (presses) requiring type III C modules (XPS-BC) conforming to standard EN 574.
See page 1/41.

Monitoring of a guard associated with a limit switch with 2 N/C contacts

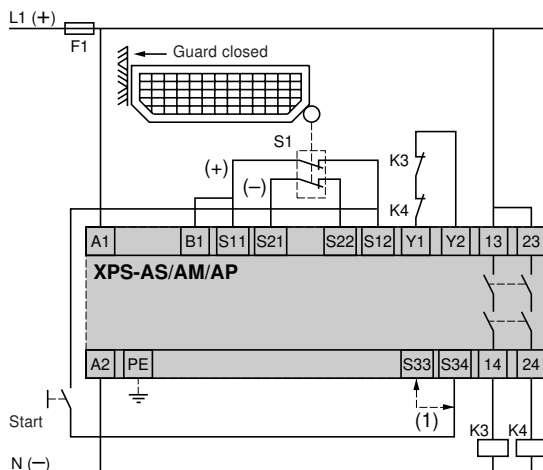

Single limit switch lock for a movable guard with manual or automatic reset after closing.
In automatic reset mode (1), synchronisation time between the two inputs is monitored. In manual reset mode, input synchronisation time is unlimited.

Monitoring of a movable guard associated with 2 limit switches with 1 contact each (limit switch 1 with N/O contact, limit switch 2 with N/C contact)

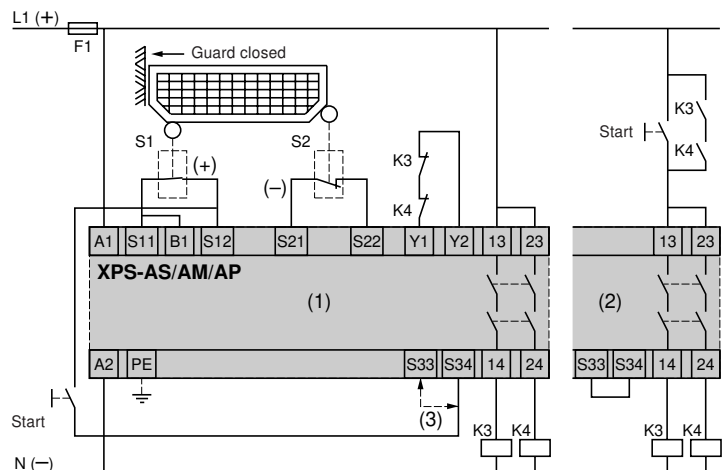

(1) Manual reset after closing, no synchronisation control of limit switches.
(2) Manual reset after closing with limit switch synchronisation check.
(3) Automatic reset after closing with limit switch synchronisation check.