

Ball Rail® Systems



Linear Motion and
Assembly Technologies

STAR – Ball Rail® Systems

Product Overview

STAR Ball Rail® Systems were specially developed for use in machine tools and industrial robots calling for compact, rolling-element linear motion guideways. Ball Rail® Systems are available in various accuracy classes, each with extremely high load capacity and high rigidity.

These compact assemblies are available in 8 common sizes and offer the same high load capacities in all four main load directions.

Make up your own compact linear motion guideways from interchangeable standard stock elements...

STAR manufactures its guide rails and runner blocks with such high precision, especially in the ball track zone, that each individual component element can be replaced by another at any time. This makes infinite combinations possible within each accuracy class.

Each element can be individually ordered and separately stocked.

Both sides of the guide rail can be used as reference edges.

- ▶ Ball Rail® Systems with integrated measuring system
(For more information see special catalog 82 350)

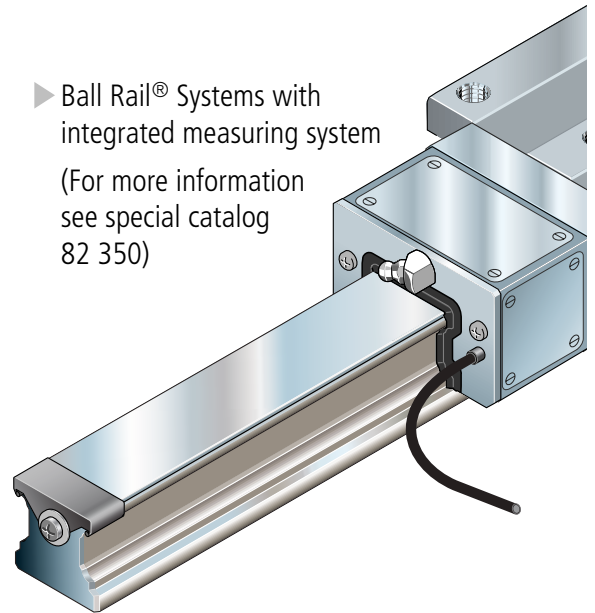

- ▶ For the majority of all applications:
STAR Runner Blocks, steel version

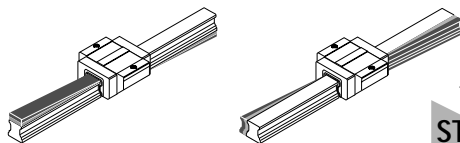

- ▶ For uneven mounting surfaces or other alignment errors:
STAR Super Runner Blocks s

- ▶ With 30% higher load capacity, super runner blocks can now attain the service life of conventional runner blocks

Proven Rail Seal® cover strip for guide rail mounting holes:

- ▶ One cover for all holes
- ▶ Material: corrosion resistant spring steel to DIN 17230 / EN 10088
- ▶ Easy clip-on mounting
- ▶ 0.3 mm Rail Seal® cover strip as standard for sizes 35 - 65

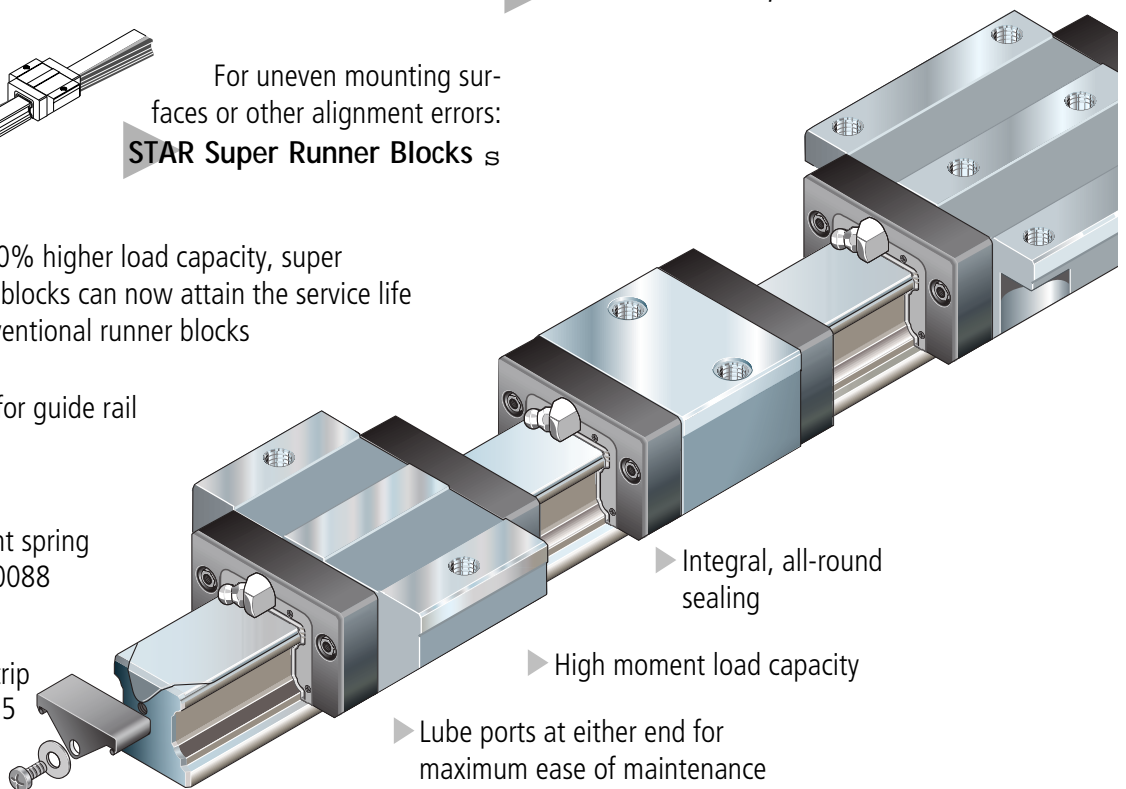

- ▶ Integral, all-round sealing
- ▶ High moment load capacity
- ▶ Lube ports at either end for maximum ease of maintenance
- ▶ One guide rail profile for all runner blocks

30% higher dynamic load capacities and moments as standard in all accuracy classes:

- extends service life by a factor of 2.2
- field-proven
- Equal load rating in all four main load directions

For lightweight applications:

STAR Runner Blocks, aluminum version

- ▶ Simline runner blocks for all configurations

For low-noise applications:

STAR Runner Blocks with spacer balls

- ▶ 4 different preload classes

- ▶ Mounting of flanged runner block from above or below

- ▶ Optimized entry-zone geometry and the high number of balls per track greatly reduce variations in elastic deflection

- ▶ Smooth, light running due to optimized ball recirculation and ideal track geometry





- ▶ End face mounting holes for attachment of bellows, lubrication plates or scraper plates

- ▶ Guide rail with mounting hole plugs

For high moment loads:
STAR Wide Ball Rail® Systems

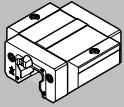
STAR – Ball Rail® Systems

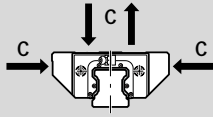
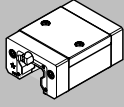
Product Overview with Load Capacities

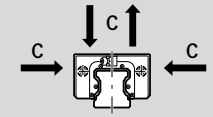
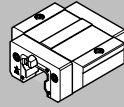
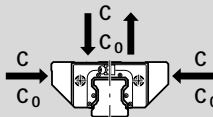
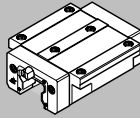
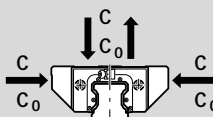
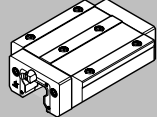
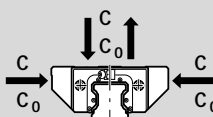
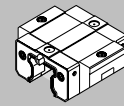
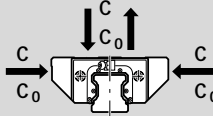
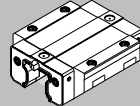
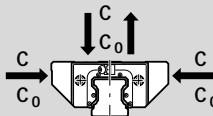
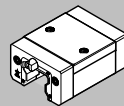
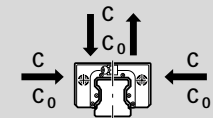
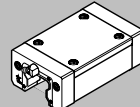
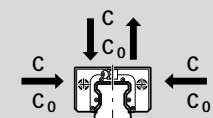
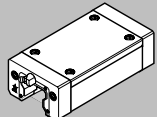
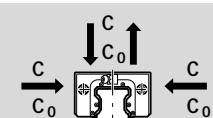
		Page	
<p>Super runner blocks, steel version with self-aligning feature</p> <p>Observe maximum load! (for details, see individual types)</p>	  <p>Standard width, short 1661-</p>	28	
	  <p>Slimline, short 1662-</p>	30	
<p>Runner blocks, steel version</p> <p>Special versions: All steel runner blocks in accuracy class N (clearance and preload 0.02 C) are also available:</p> <ul style="list-style-type: none"> – with zinc-iron coating and yellow chromating (part numbers 16...4-30), – with low-friction seal (part numbers 16...4-11). <p>Preferred versions: 1651-, 1653-, 1622- and 1623-.</p>	 <p>Standard width, short 1665-</p>	44	
	 <p>Standard width 1651-</p>	46	
	 <p>Standard width, long 1653-</p>	48	
	 <p>Standard width, short, low profile 1663-</p>	50	
	 <p>Standard width, low profile 1693-</p>	52	
	 <p>Slimline, short 1666-</p>	54	
	 <p>Slimline 1622-</p>	56	
	 <p>Slimline, long 1623-</p>	58	

STAR – Ball Rail® Systems

Product Overview with Load Capacities

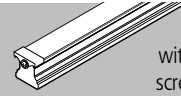
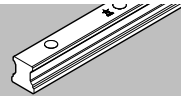
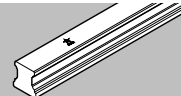
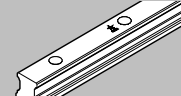
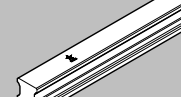
		Page		
Guide rails *Also available as special version: zinc-iron coating with yellow chromating in accuracy class N	 <p>For mounting from above, with Rail Seal cover strip and screw-down protective caps* 1605-6.-</p>	80		
	 <p>For mounting from above, with plastic (or steel) mounting hole plugs* 1605-0.- (1606-0.-)</p>	82		
	 <p>For mounting from below* 1607-</p>	84		
	 <p>For mounting from above – thin dense chrome plated 1645-</p>	86		
	 <p>For mounting from below – thin dense chrome plated 1647-</p>	88		
	<ul style="list-style-type: none"> - Rail Seal mounting hole cover strip - Mounting hole plugs - Protective caps 			

Basis for load capacities p. 11:

Determination of load dynamic capacity C is based on a travel life of 100,000 m to DIN 636. Load capacities on the basis of 50,000 m are also given for comparison.

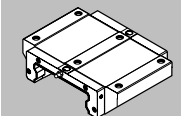
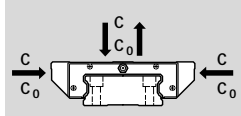
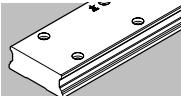
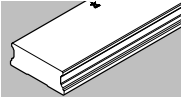
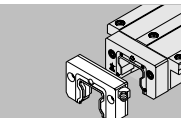
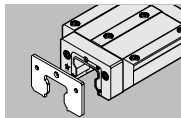
Wide Ball Rail Systems Runner Blocks, steel version	 <p>Wide 1671-</p>	96		
Wide Ball Rail Systems Guide rails	 <p>Wide, for mounting from above* 1675-</p>	98		
Also available as special version: zinc-iron coating with yellow chromating in accuracy class N	 <p>Wide, for mounting from below 1677-</p>	100		
Accessories	 <p>Front lube unit</p>	102	 <p>Scraper plate</p>	



STAR – Ball Rail® Systems

Super Runner Blocks Σ Steel Version

Super Runner Block Σ
with self-aligning feature 1661-
Standard width, short

Special versions:

Runner blocks in accuracy class N
(clearance and preload 0.02 C) are
also available:

- with zinc-iron coating and yellow chromating
(part numbers 16...-4-30),
- with low friction seals
(part numbers 16...-4-11).

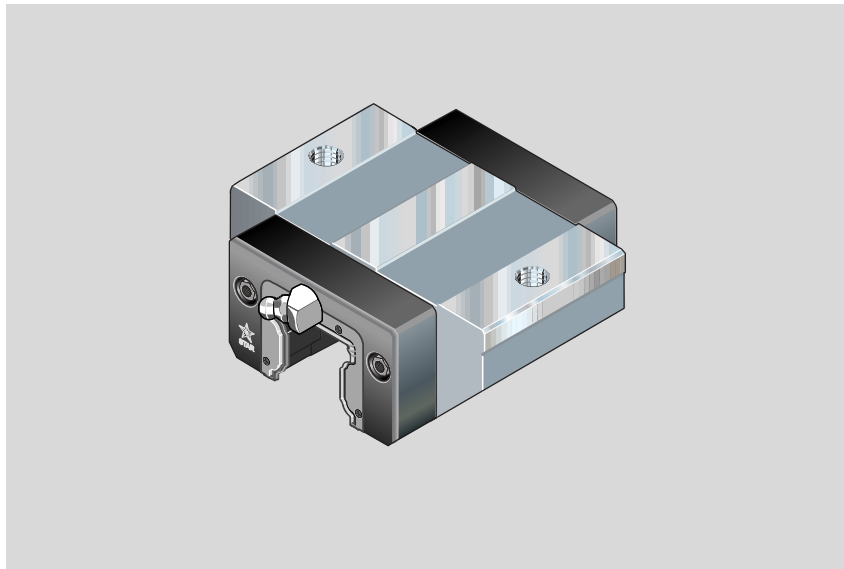

Part numbers

Size	Accuracy class	Part numbers for runner block for preload class	
		up to approx. 10 μ m clearance	Preload 0.02 C
15	H	1661-193-10	1661-113-10
	N	1661-194-10	1661-114-10
20	H	1661-893-10	1661-813-10
	N	1661-894-10	1661-814-10
25	H	1661-293-10	1661-213-10
	N	1661-294-10	1661-214-10
30	H	1661-793-10	1661-713-10
	N	1661-794-10	1661-714-10
35	H	1661-393-10	1661-313-10
	N	1661-394-10	1661-314-10

Permissible load

When calculating the service life, use the maximum load capacity figure.

The permissible load is only limited for statistical purposes (see table).

Note on dynamic load capacities and moments (see table)

Determination of dynamic load capacities and moments is based on a travel life of 100,000 m.

For comparison with the 50,000 m travel sometimes applied for rail-type guideways, the figures for **C** and **M_t** in the table should be multiplied by 1.26.



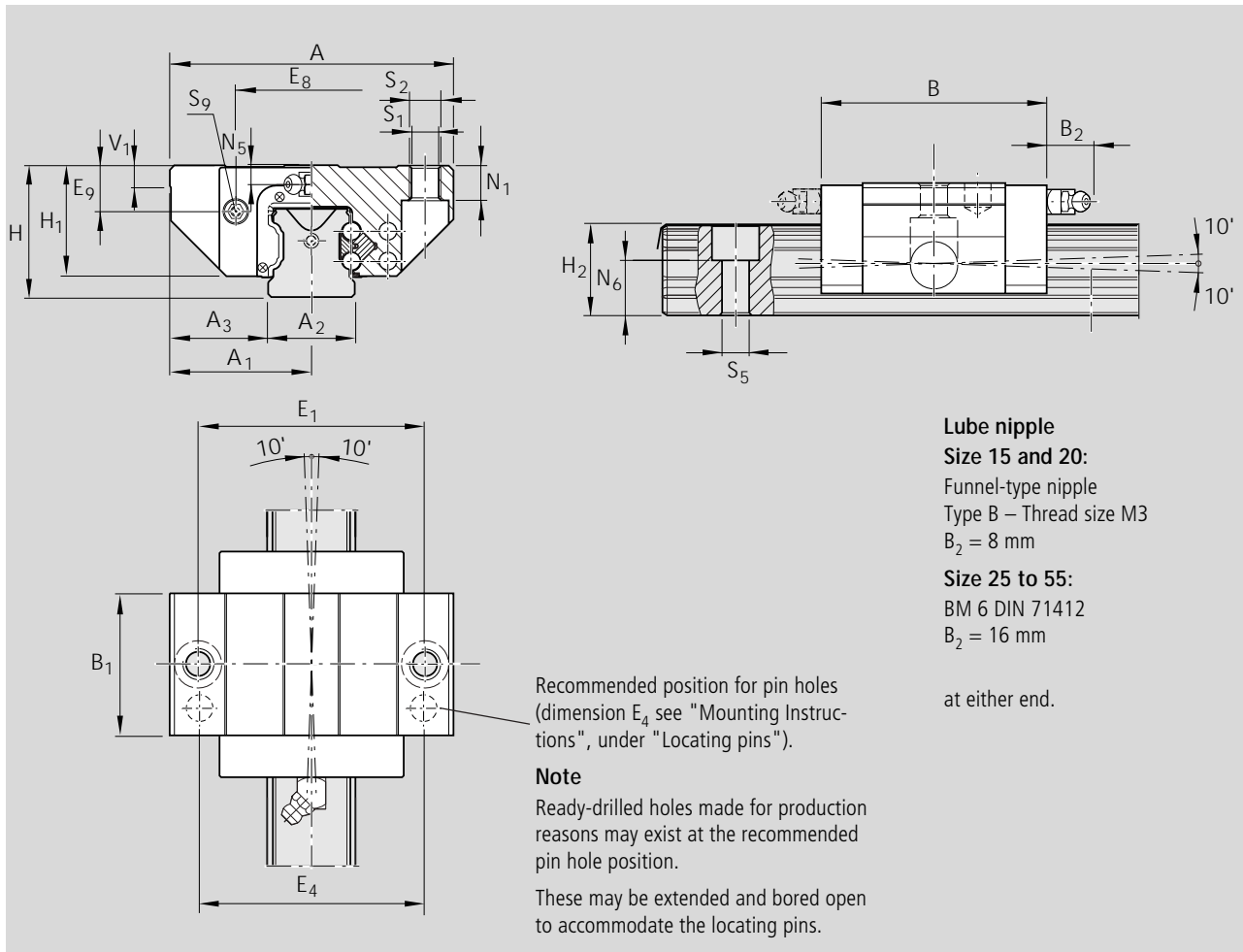

Dimensions (mm)																
Size	A	A ₁	A ₂	A ₃	B	B ₁	H	H ₁	H ₂ ¹⁾	H ₂ ²⁾	V ₁	E ₁		E ₈	E ₉	N ₁
15	47	23.5	15	16.0	40.5	25.7	24	19.8	16.3	16.20	5.0	38		24.55	6.7	5.0
20	63	31.5	20	21.5	52.5	31.9	30	25.4	20.7	20.55	6.0	53		32.4	7.3	7.5
25	70	35.0	23	23.5	61.5	38.6	36	29.5	24.4	24.25	7.5	57		38.3	11.5	9.0
30	90	45.0	28	31.0	71.5	45.0	42	35.0	28.5	28.35	7.0	72		48.4	14.6	11.0
35	100	50.0	34	33.0	79.0	51.4	48	40.0	32.15	31.85	8.0	82		58.0	17.5	12.0

¹⁾ Dimension H_2 with Rail Seal cover strip

²⁾ Dimension H_2 without Rail Seal cover strip

Size	Dimensions (mm)						Mass (kg)	Load capacities (N)	Permissible load (N)	Moments (Nm)	
	N ₅	N ₆ ^{±0.5}	S ₁	S ₂	S ₅	S ₉		C dyn.		F _{max}	M _t dyn.
15	4.0	10.3	4.4	M5	4.4	M2.5-3.5deep	0.19	3 900	1 500	39	15
20	4.7	13.2	5.4	M6	6.0	M3-5 deep	0.43	10 100	3 900	130	50
25	5.5	15.2	6.8	M8	7.0	M3-5 deep	0.50	11 400	4 400	170	65
30	6.0	17.0	8.6	M10	9.0	M3-5 deep	0.90	15 800	6 100	270	105
35	7.0	20.5	8.6	M10	9.0	M3-5 deep	1.35	21 100	8 100	450	175

30% higher dynamic load capacities and moments than previous design



STAR – Ball Rail® Systems

Super Runner Blocks Σ Steel Version

Super Runner Block Σ
with self-aligning feature 1662-
Slimline, short

Special versions:

Runner blocks in accuracy class N
(clearance and preload 0.02 C)
are also available:

- with zinc-iron coating and yellow chromating
(part numbers 16...4-30),
- with low friction seals
(part numbers 16...4-11).

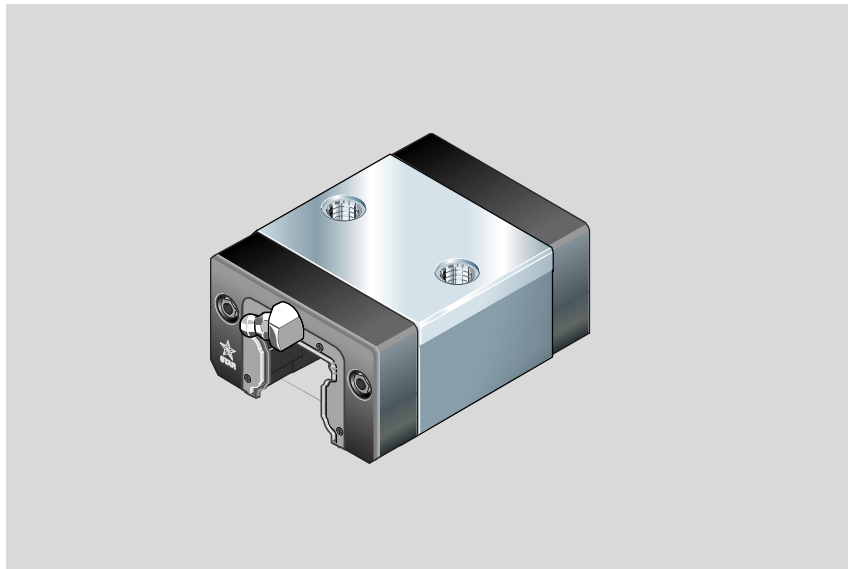

Part numbers

Size	Accuracy class	Part numbers for runner block for preload class	
		up to approx. 10 μm clearance	Preload 0.02 C
15	H	1662-193-10	1662-113-10
	N	1662-194-10	1662-114-10
20	H	1662-893-10	1662-813-10
	N	1662-894-10	1662-814-10
25	H	1662-293-10	1662-213-10
	N	1662-294-10	1662-214-10
30	H	1662-793-10	1662-713-10
	N	1662-794-10	1662-714-10
35	H	1662-393-10	1662-313-10
	N	1662-394-10	1662-314-10

Permissible load

When calculating the service life, use the maximum load capacity figure.

The permissible load is only limited for statistical purposes (see table).

Note on dynamic load capacities and moments (see table)

Determination of dynamic load capacities and moments is based on a travel life of 100,000 m.

For comparison with the 50,000 m travel sometimes applied for rail-type guideways, the figures for **C** and **M_t** in the table should be multiplied by 1.26.



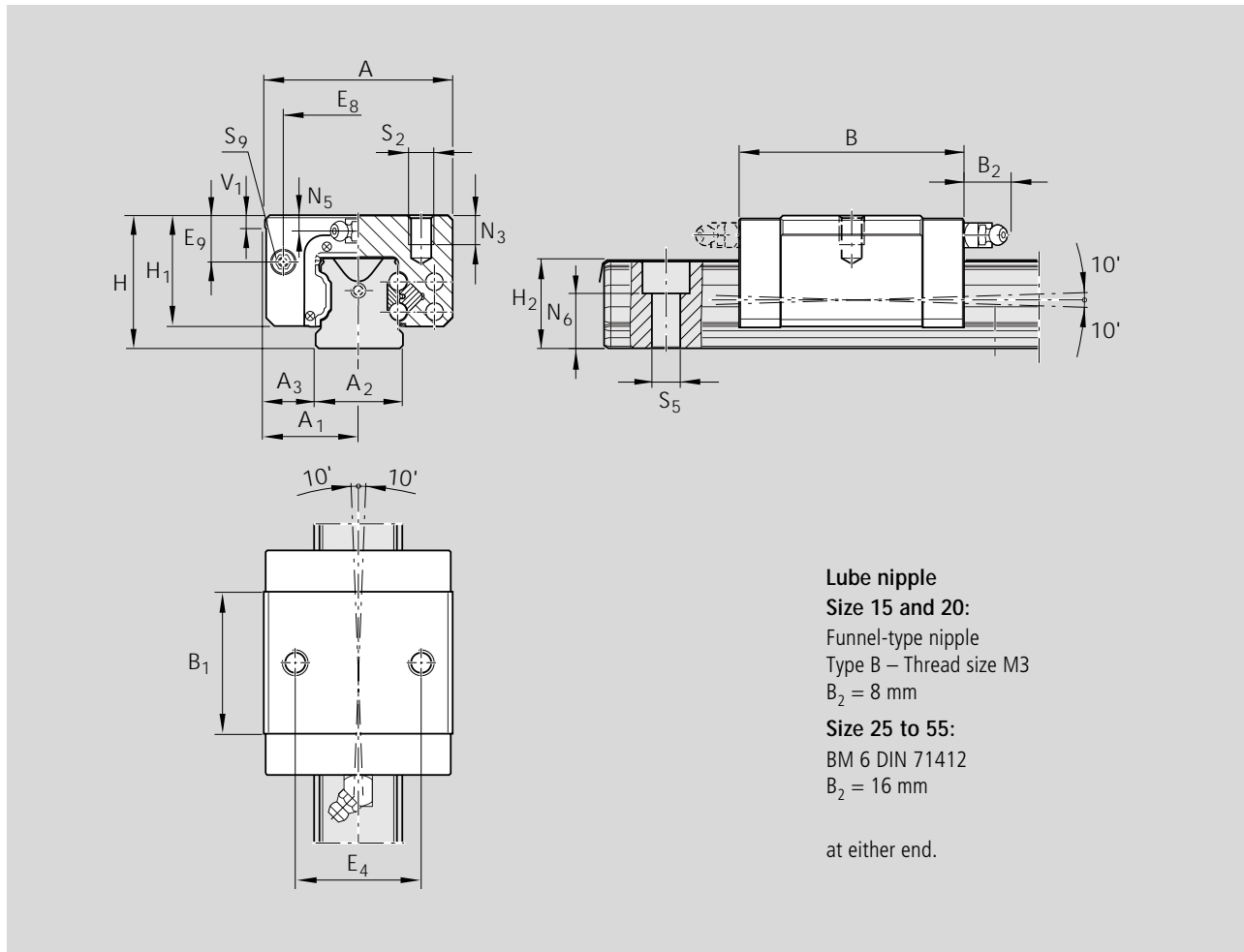

Dimensions (mm)																
Size	A	A ₁	A ₂	A ₃	B	B ₁	H	H ₁	H ₂ ¹⁾	H ₂ ²⁾	V ₁	E ₁	E ₈	E ₉		N ₃
15	34	17	15	9.5	40.5	25.7	24	19.8	16.3	16.20	5.0	26	24.55	6.7		6.0
20	44	22	20	12.0	52.5	31.9	30	25.4	20.7	20.55	6.0	32	32.4	7.3		7.5
25	48	24	23	12.5	61.5	38.6	36	29.5	24.4	24.25	7.5	35	38.3	11.5		9.0
30	60	30	28	16.0	71.5	45.0	42	35.0	28.5	28.35	7.0	40	48.4	14.6		12.0
35	70	35	34	18.0	79.0	51.4	48	40.0	32.15	31.85	8.0	50	58.0	17.5		

1) Dimension H₂ with Rail Seal cover strip

2) Dimension H₂ without Rail Seal cover strip

Size	Dimensions (mm)					Mass (kg)	Load capacities (N)	Permissible load (N)	Moments (Nm)	
	N ₅	N ₆ ^{±0.5}	S ₂	S ₅	S ₉		C dyn.	F _{max}	M _t dyn.	M _t max.
15	4.0	10.3	M4	4.4	M2.5-3.5 deep	0.12	3 900	1 500	39	15
20	4.7	13.2	M5	6.0	M3-5 deep	0.30	10 100	3 900	130	50
25	5.5	15.2	M6	7.0	M3-5 deep	0.40	11 400	4 400	170	65
30	6.0	17.0	M8	9.0	M3-5 deep	0.65	15 800	6 100	270	105
35	7.0	20.5	M8	9.0	M3-5 deep	0.95	21 100	8 100	450	175

30% higher dynamic load capacities and moments than previous design



STAR – Ball Rail® Systems

Product Description Runner Blocks, Steel Version

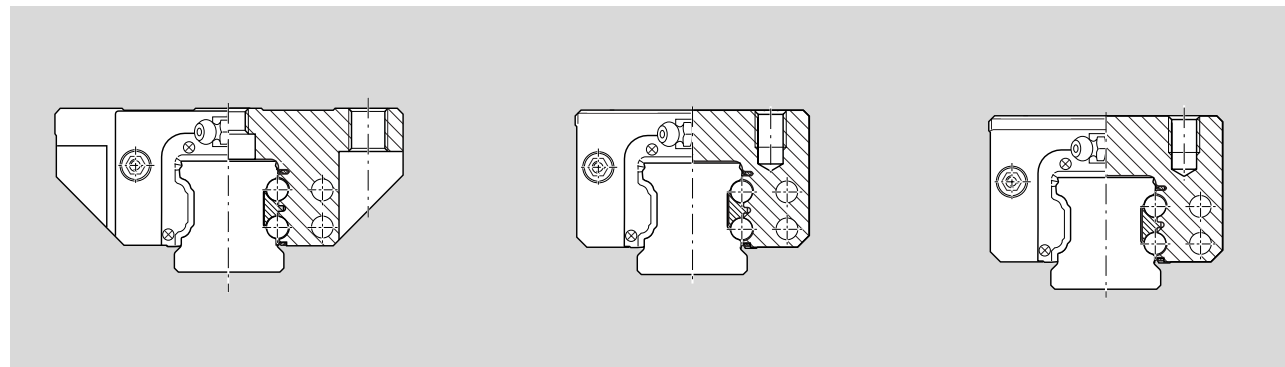
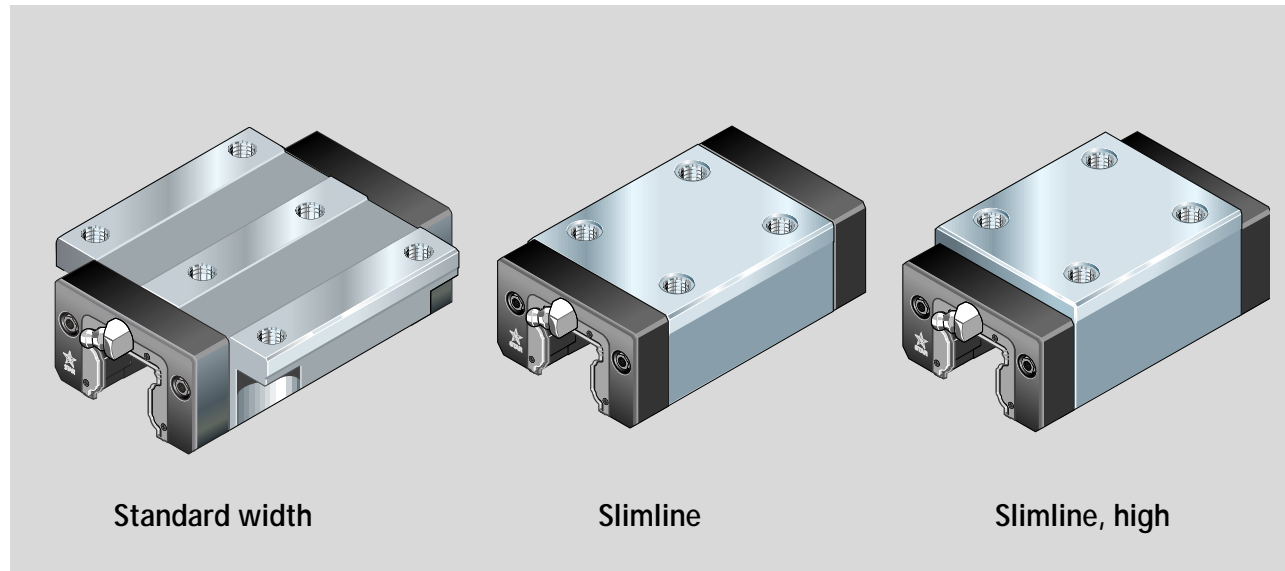

These figures are also valid for the long versions.

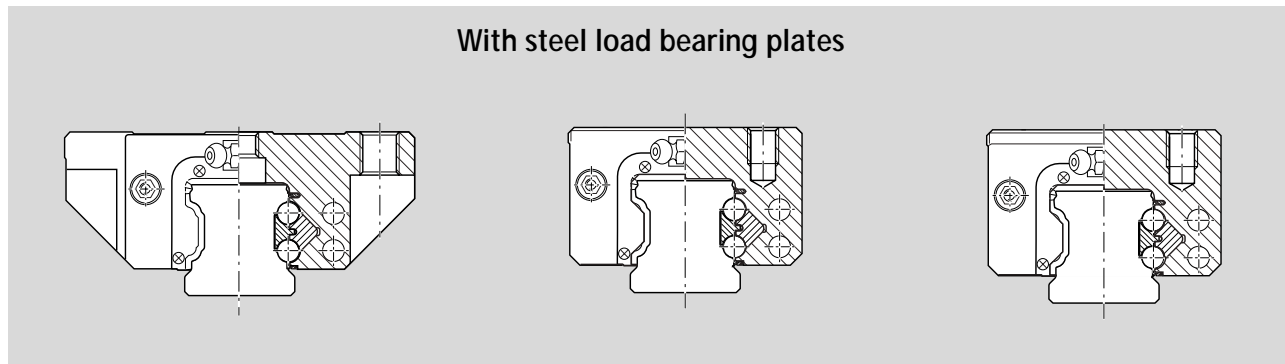

The Ball Rail® System consists of:

- A guide rail with all surfaces ground and ball track zones hardened
- A runner block with all surfaces ground and ball track zones hardened, made of rolling bearing steel or with hardened and ground steel load bearing plates with
 - cage designed for optimum ball recirculation
 - integral all-round sealing of all ball tracks
 - bearing steel balls

Technical Data

Accuracy classes and their tolerances (µm)

STAR Ball Rail® Systems are offered in up to five different accuracy classes.

For available versions see table "Part Numbers".

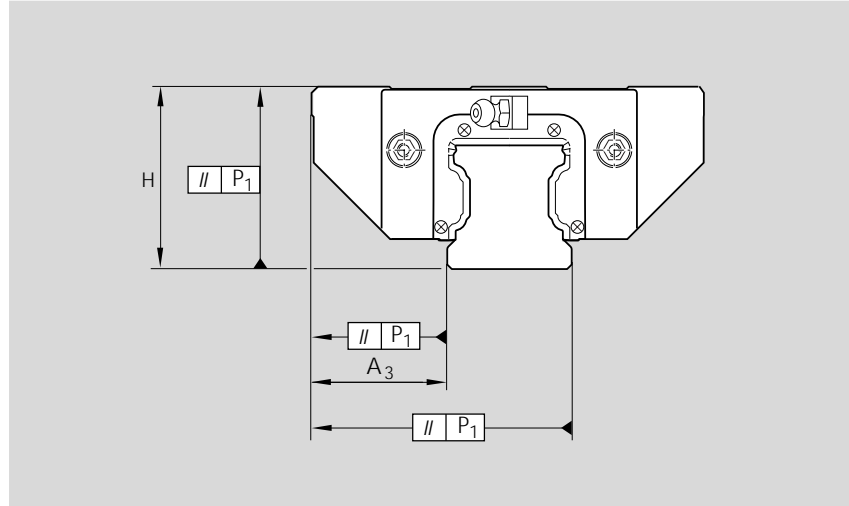

Built-in interchangeability through precision machining

STAR manufactures its guide rails and runner blocks with such high precision, especially in the ball track zone, that each individual component element can be replaced by another at any time.

A runner block can be used without problems on various guide rails of the same size, for example.

This applies equally to the use of different runner blocks on one and the same guide rail.

Accuracy classes	Dimensional tolerances H and A ₃ (µm)		Max. difference in dimensions H and A ₃ on the same rail ΔH, ΔA ₃ (µm)
	H	A ₃	
UP	± 5	± 5	3
SP	± 10	± 7	5
P	± 20	± 10	7
H	± 40	± 20	15
N	± 100	± 40	30

Measured at middle of runner block:	<p>For any runner block/rail combination at any position on rail</p>	<p>For different runner blocks at same position on rail</p>
-------------------------------------	--	---

Parallelism offset P₁ of the Ball Rail® System in service

Measured at middle of runner block

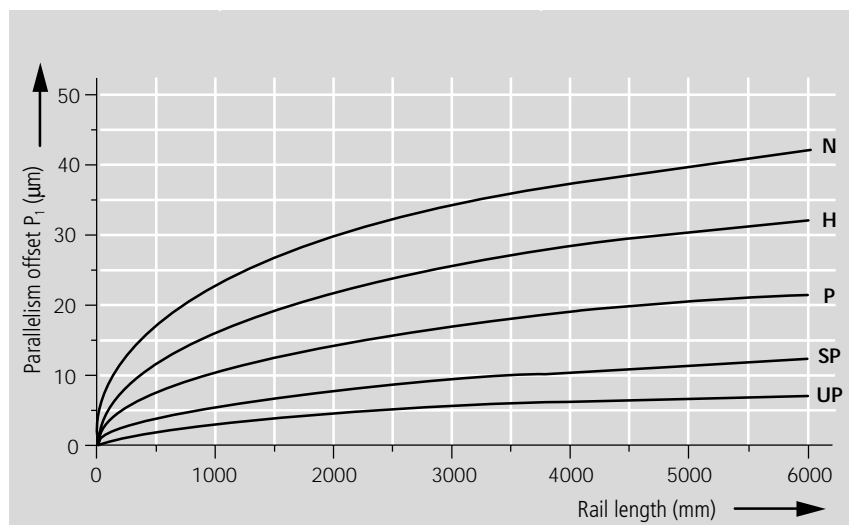

STAR – Ball Rail® Systems

Technical Data – Runner Blocks, Steel Version

Rigidity of the Ball Rail® System at 0.08 C preload

Runner block 1651-
Standard width

————— measured values

Runner block mounted using
six screws:

- 4 outer screws of strength class 12.9
- 2 centerline screws of strength class 8.8

1. Down load

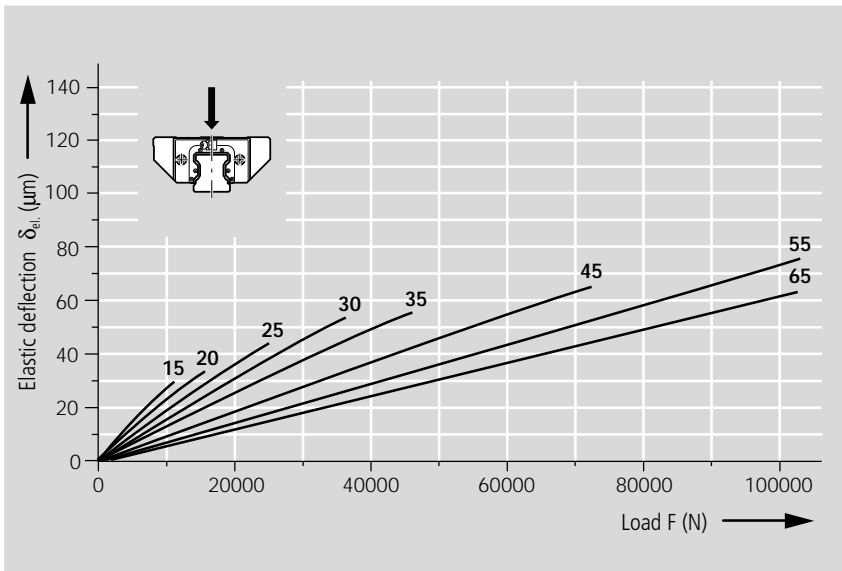

2. Lift-off load

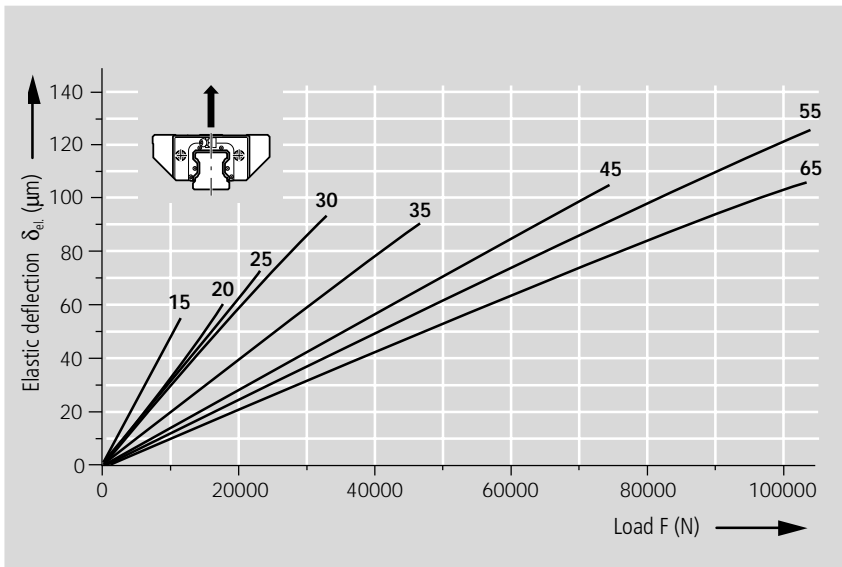

3. Side load

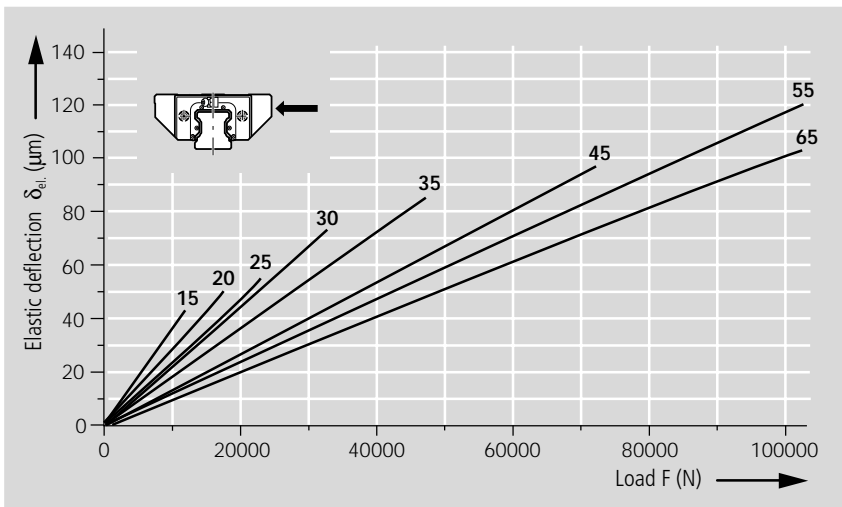

Rigidity of the Ball Rail® System at 0.02 C preload

Runner block 1666-Slimline, short

————— measured values
 - - - - - calculated values

Runner block mounted with two screws, screw strength class 8.8

1. Down load

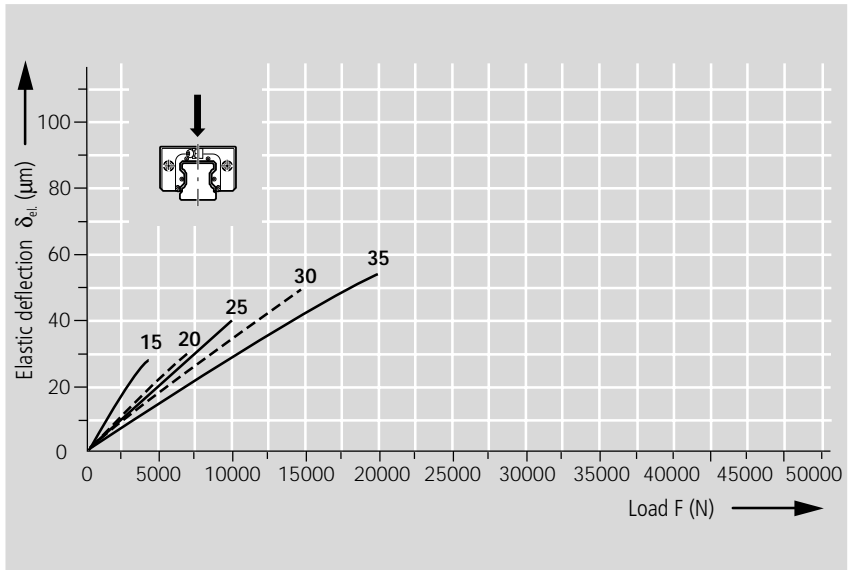

2. Lift-off load

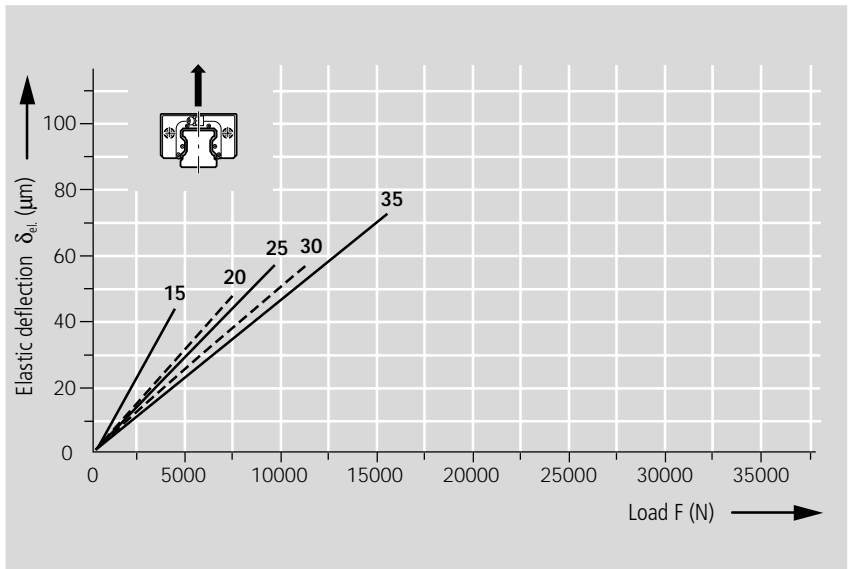

3. Side load

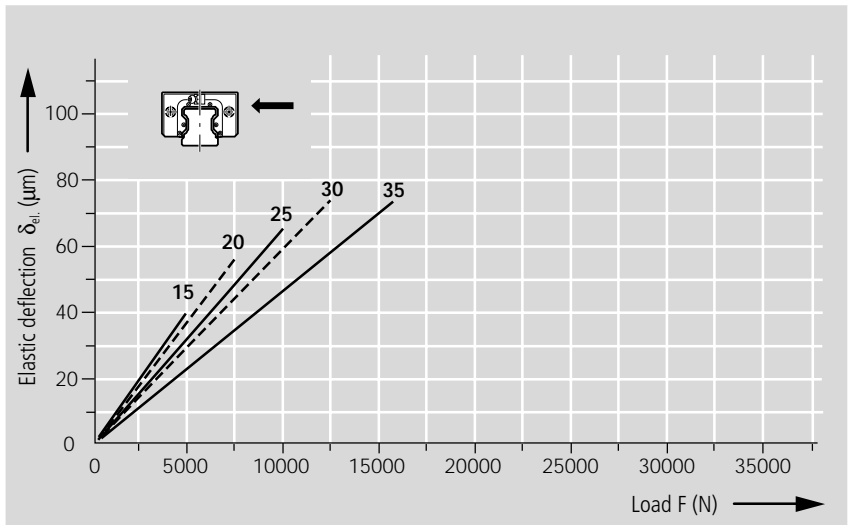

STAR – Ball Rail® Systems Mounting Instructions

For guide rails with runner block
1621-, 1622-, 1623-, 1624-, 1651-, 1653-, 1694-

Reference edges, corner radii,
mounting screw sizes and
tightening torque

Runner block 1651-, 1653-

- Standard width

Guide rails

left:

- For mounting from above 1605-, 1645-

right:

- For mounting from below 1607-, 1647

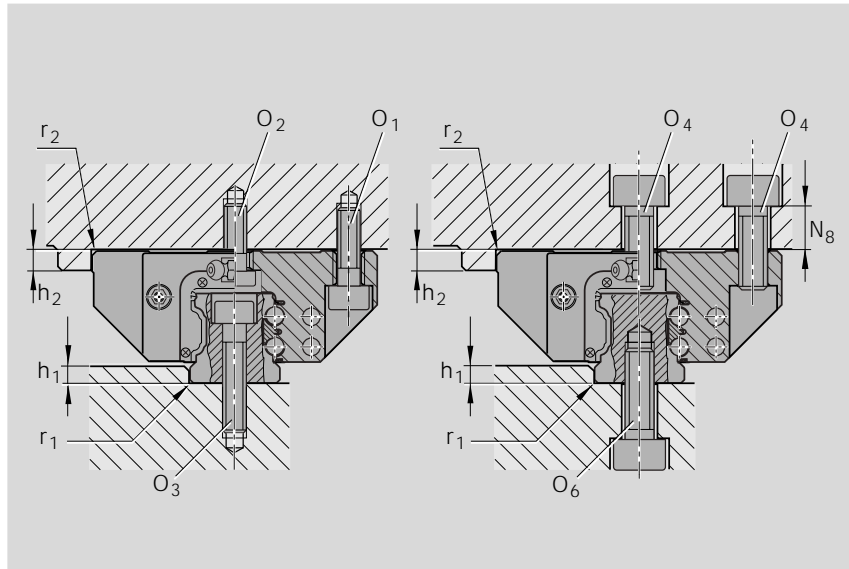

Runner block 1621-, 1622-, 1623-, 1624-, 1694-

- Slimline

Guide rail

- For mounting from above 1605-, 1645-

Note

The indicated combinations represent examples. It is on principle possible to combine any runner block with all the offered guide rail types.

Dimensions and recommended limits for side load if no additional lateral retention is provided

- When mounting the runner block from above using only 4 O₄ screws:
 - Permissible side force 1/3 lower
 - Lower rigidity

- For runner block mounting with 6 screws:
 - Tighten the centerline screws with the torque for strength class 8.8

- When mounting with 2 O₂ screws and 4 O₁ screws

- Runner block 1621-, 1622-, 1651-, 1694-
- Runner block 1623-, 1624-, 1653-

Tightening torque of the mounting screws

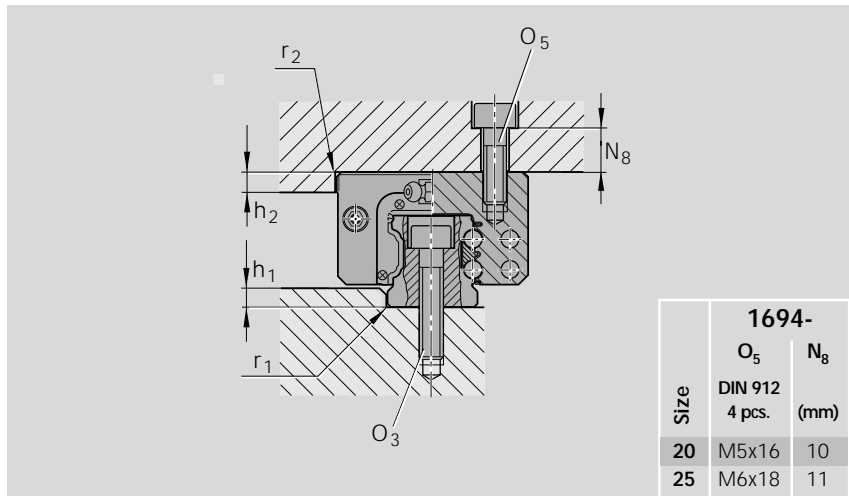

Size	h ₁		r ₁	h ₂		r ₂	O ₁	O ₂ ²⁾	O ₄ ¹⁾²⁾	O ₅	O ₃	O ₆	N ₈
	min. (mm)	max. (mm)		max. (mm)	max. (mm)		DIN 912 4 pcs.	DIN 6912 2 pcs.	DIN 912 6 pcs.	DIN 912 4 pcs.	DIN 912	DIN 912	
15	2.5	3.5	0.4	4	0.6	0.6	M4x12	M4x10	M5x12	M4x12	M4x20	M5x12	6
20	2.5	4.0	0.6	5	0.6	0.6	M5x16	M5x12	M6x16	M5x16	M5x25	M6x16	9
25	3.0	5.0	0.8	5	0.8	0.8	M6x20	M6x16	M8x20	M6x18	M6x30	M6x20	10
30	3.0	5.0	0.8	6	0.8	0.8	M8x25	M8x16	M10x20	M8x20	M8x30	M8x20	10
35	3.5	6.0	0.8	6	0.8	0.8	M8x25	M8x20	M10x25	M8x25	M8x35	M8x25	13
45	4.5	8.0	0.8	8	0.8	0.8	M10x30	M10x25	M12x30	M10x30	M12x45	M12x30	14
55	7.0	10.0	1.2	10	1.0	1.0	M12x40	M12x30	M14x40	M12x35	M14x50	M14x40	20
65	7.0	10.0	1.2	14	1.0	1.0	M14x45	M14x35	M16x45	M16x40	M16x60	M16x45	22

Screw strength class	Runner blocks				Guide rails		
	0.11 C	0.15 C ³⁾	0.23 C	0.11 C	0.06 C	0.06 C	
8.8	0.11 C	0.15 C ³⁾	0.23 C	0.11 C	0.06 C	0.06 C	
12.9	0.18 C	0.22 C ³⁾	0.35 C	0.18 C	0.10 C	0.10 C	
8.8	0.08 C	0.13 C ³⁾	0.18 C	0.08 C	0.04 C	0.04 C	
12.9	0.14 C	0.18 C ³⁾	0.26 C	0.14 C	0.07 C	0.07 C	

Nm	Screw sizes							
	M4	M5	M6	M8	M10	M12	M14	M16
8.8	2.7	5.5	9.5	23	46	80	125	195
12.9	4.6	9.5	16	39	77	135	215	340



Locating pins

If the recommended values for permissible side forces are exceeded (see table), the runner block must be additionally fixed by means of locating pins or reference edges.

Recommended dimensions for the pin holes are indicated in the drawings and table.

Possible pin types

- Taper pin (hardened) or
- Straight pin DIN 6325

Note

Ready-drilled holes made for production reasons may exist at the recommended pin hole positions ($\varnothing < S_{10}$).

These may be extended and bored open to accommodate the locating pins.

If the locating pins have to be driven in at another point (e.g. when the lube port is central), dimension E_2 must not be exceeded in the longitudinal direction (for dimension E_2 , see the tables for the individual types).

Observe dimensions E_1 and E_4 !

Only prepare the pin holes after the installation is complete (see also "General Mounting Instructions").

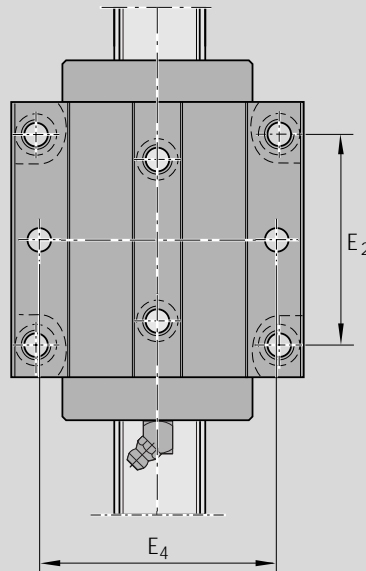
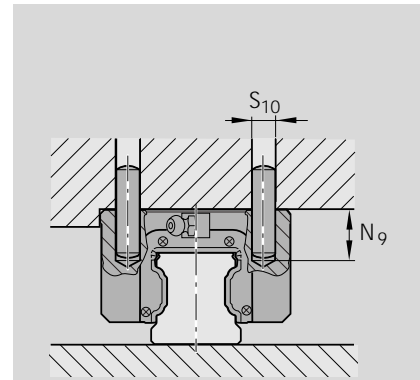
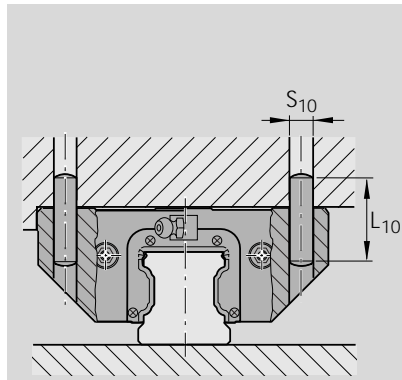

Standard width 1651-, 1653-

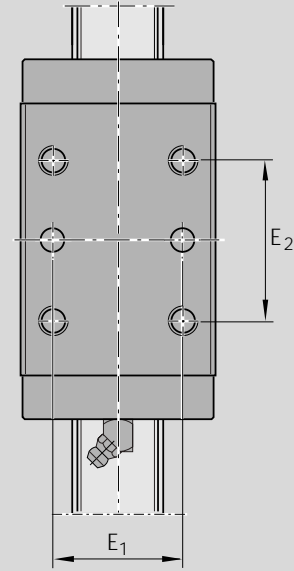

Slimline 1622-, 1623-
Slimline, high 1621-, 1624-
Slimline, low profile 1694-

Size	Dimensions (mm)					
	Taper pin (hardened) or Straight pin (DIN 6325)		E_1	E_4	N_9 (max)	1694-
S_{10}	L_{10}	N_9 (max)				
15	4	18	26	38	6.0	-
20	5	24	32	53	7.5	6.5
25	6	32	35	55	9.0	7.0
30	8	36	40	70	12.0	-
35	8	40	50	80	13.0	-
45	10	50	60	98	18.0	-
55	12	60	75	114	19.0	-
65	14	60	76	140	22.0	-

STAR – Ball Rail® Systems Mounting Instructions

For rail systems with runner block 1665-, 1666-

Reference edges, corner radii,
mounting screw sizes and
tightening torque

Runner block 1665-

- Standard width, short

Guide rails

left:

- For mounting from above 1605-

right:

- For mounting from below 1607-

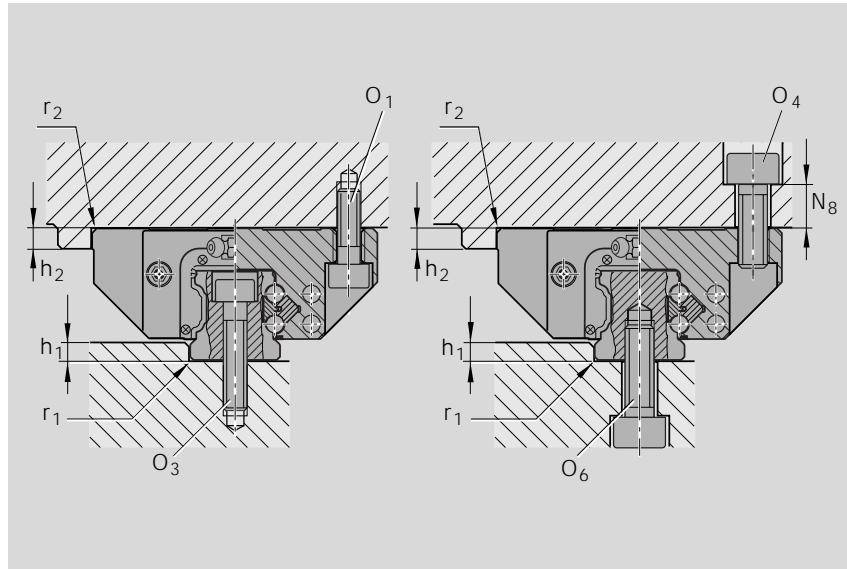

Runner block 1666-

- Slimline, short

Guide rails

- For mounting from above 1605-

Note

The indicated combinations represent examples. It is on principle possible to combine any runner block with all the offered guide rail types.

Screw mounting of runner blocks using two screws is fully sufficient up to maximum load. (See maximum permissible force and moment loads indicated under the individual types.)

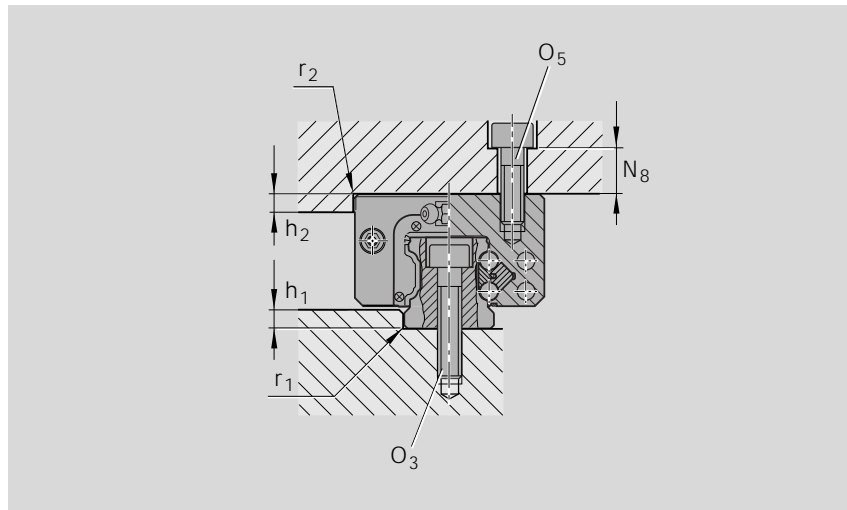

Dimensions and recommended limits
for side load if no additional lateral
retention is provided
(Runner blocks 1665-, 1666-)

Size	h ₁		r ₁	h ₂		r ₂	O ₁	O ₄	O ₅	O ₃	O ₆	N ₈
	min. (mm)	max. (mm)	max. (mm)	(mm)	max. (mm)	(mm)	DIN 912 2 pcs.	DIN 912 2 pcs.	DIN 912 2 pcs.	DIN 912 (rail)	DIN 912 (rail)	(mm)
15	2.5	3.5	0.4	4	0.6	0.6	M4x12	M5x12	M4x12	M4x20	M5x12	6
20	2.5	4.0	0.6	5	0.6	0.6	M5x16	M6x16	M5x16	M5x25	M6x16	9
25	3.0	5.0	0.8	5	0.8	0.8	M6x20	M8x20	M6x18	M6x30	M6x20	10
30	3.0	5.0	0.8	6	0.8	0.8	M8x25	M10x20	M8x20	M8x30	M8x20	10
35	3.5	6.0	0.8	6	0.8	0.8	M8x25	M10x25	M8x25	M8x35	M8x25	13

Screw strength class	Runner blocks			Guide rails		
	8.8	0.08 C	0.12 C	0.08 C	0.09 C	0.09 C
	12.9	0.13 C	0.21 C	0.13 C	0.15 C	0.15 C

Tightening torque of the
mounting screws

Nm	Screw sizes								
	M4	M5	M6	M8	M10	M12	M14	M16	
8.8	2.7	5.5	9.5	23	46	80	125	195	
12.9	4.6	9.5	16	39	77	135	215	340	



Locating pins

If the recommended values for permissible side forces are exceeded, the runner block must be additionally fixed by means of locating pins or reference edges.

Recommended dimensions for the pin holes are indicated in the drawings and table.

Possible pin types

- Taper pin (hardened) or
- Straight pin DIN 6325

Note

Ready-drilled holes made for production reasons may exist at the recommended pin hole positions ($\varnothing < S_{10}$).

These may be extended and bored open to accommodate the locating pins.

Only prepare the pin holes after the installation is complete (see also "General Mounting Instructions").

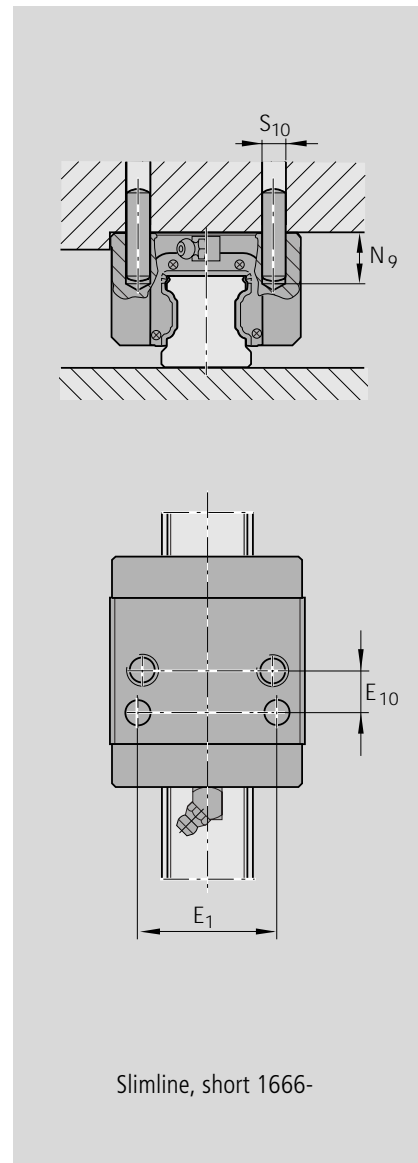
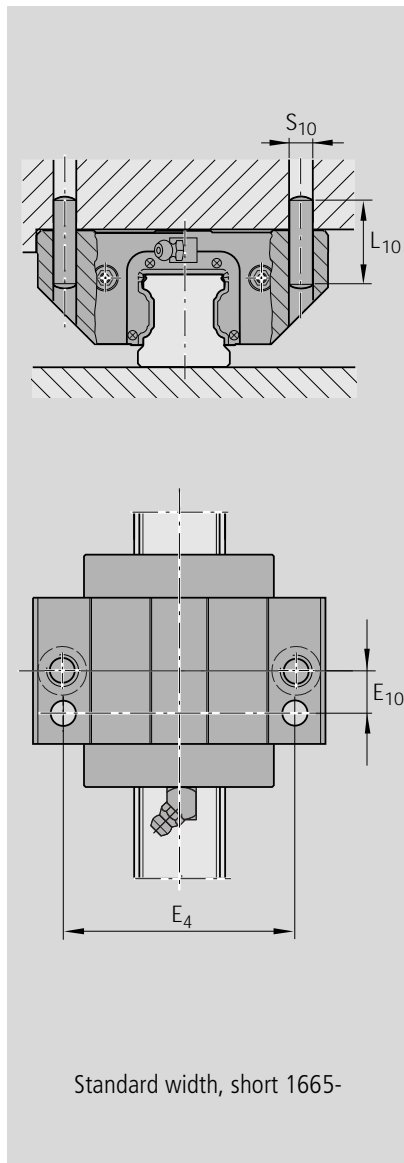

Size	Dimensions (mm)					
	Taper pin (hardened) or Straight pin (DIN 6325)		E ₁	E ₄	E ₁₀	N ₉ (max)
S ₁₀	L ₁₀					
15	4	18	26	38	9	3.0
20	5	24	32	53	10	3.5
25	6	32	35	55	11	7.0
30	8	36	40	70	14	10.0
35	8	40	50	80	15	12.0

STAR – Ball Rail® Systems

Mounting Instructions – Runner Blocks, Steel Version

Parallelism offset of the rails after mounting

measured at the guide rails and at the runner blocks

The values for parallelism offset P_1 apply to all runner blocks of the standard range. Values around 20% higher are permissible for the runner block 1665- (standard width, short) and 1666- (slimline, short).

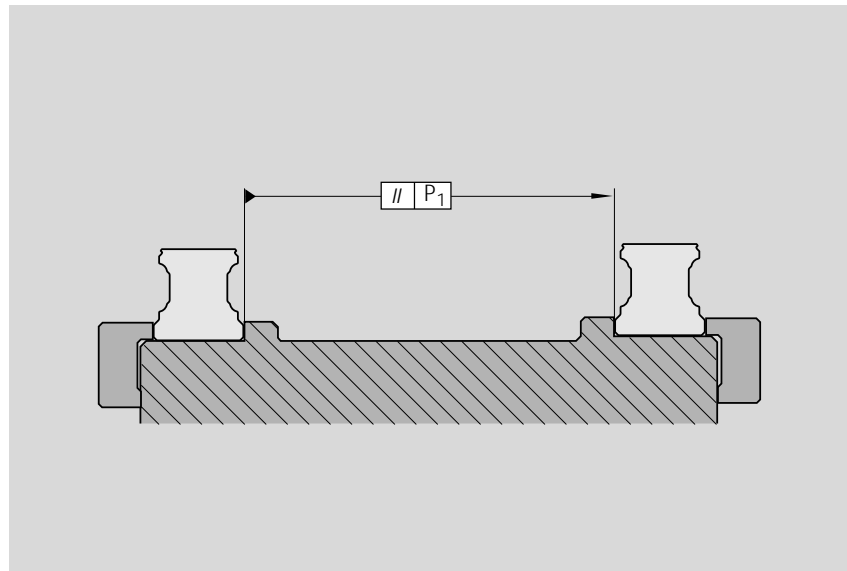

Note

The parallelism offset P_1 causes a slight increase in preload on one side of the assembly.

If the tolerances given in the table are not exceeded, reduction in travel life will as a rule be negligible.

The given values apply to precision mounting. For standard mounting, double the stated values can be used.

Size	Parallelism offset P_1 (mm)			
	up to approx. 10 μm clearance	Preload 0.02 C	Preload 0.08 C	Preload 0.13 C
15	0.015	0.009	0.005	0.004
20	0.018	0.011	0.006	0.004
25	0.019	0.012	0.007	0.005
30	0.021	0.014	0.009	0.006
35	0.023	0.015	0.010	0.007
45	0.028	0.019	0.012	0.009
55	0.035	0.025	0.016	0.011
65	0.048	0.035	0.022	0.016

Vertical offset

The vertical offset values apply to all runner blocks of the standard program.

Values around 20% higher are permissible for the runner block 1665- (standard width, short) and 1666- (slimline, short).

If the admissible vertical offset S_1 and S_2 is not exceeded, reduction in travel life will as a rule be negligible.

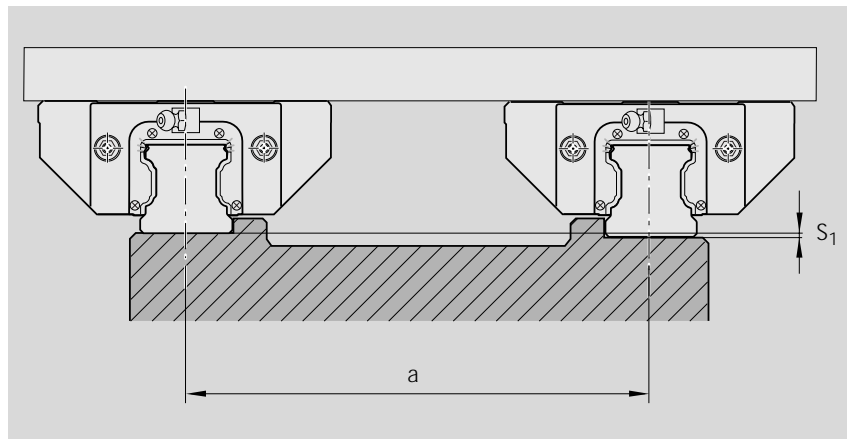

Permissible vertical offset in the transverse direction

The permissible vertical offset S_1 includes the tolerance for dimension H in accordance with the table given in the "Technical Data" section.

$$S_1 = a \cdot Y$$

S_1 = permissible vertical offset (mm)
 a = distance between rails (mm)
 Y = calculation factor

Calculation factor	for preload class			
	up to approx. 10 μm clearance	Preload 0.02 C	Preload 0.08 C	Preload 0.13 C
Y	$4.3 \cdot 10^{-4}$	$2.8 \cdot 10^{-4}$	$1.7 \cdot 10^{-4}$	$1.2 \cdot 10^{-4}$



Permissible vertical offset in the longitudinal direction

The permissible vertical offset S_2 includes the tolerance "Max. difference in dimension H on the same rail" in accordance with the table given in the "Technical Data" section.

Values around 40% higher are permissible for the runner block 1665- (standard width, short) and 1666- (slimline, short).

Values around 30% lower are permissible for runner block 1653- (standard width long), 1623- (slimline, long) and 1624- (slimline, high, long).

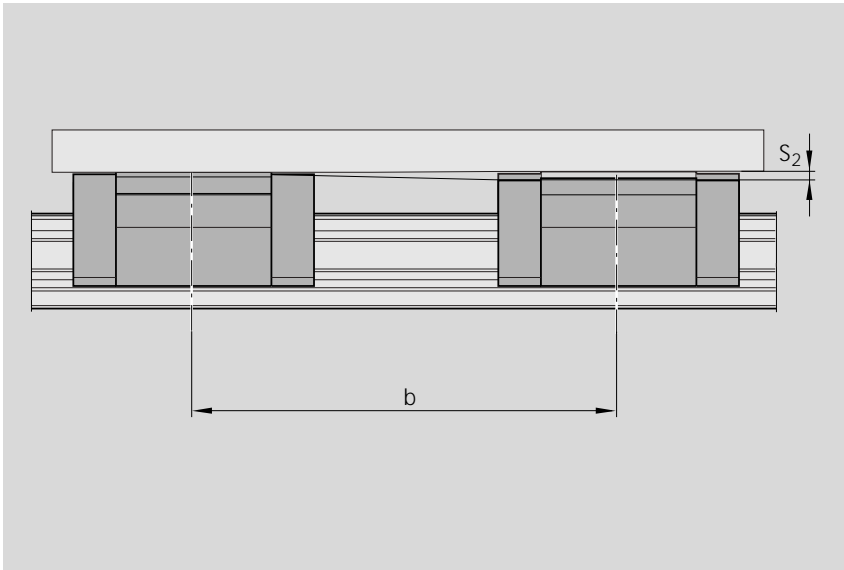

$$S_2 = b \cdot 4.3 \cdot 10^{-5}$$

S_2 = permissible vertical offset (mm)
 b = distance between runner blocks (mm)

STAR – Ball Rail® Systems

Runner Blocks, Steel Version

Runner Block 1665- Standard width, short

Special versions:

Runner blocks in accuracy class N (clearance and preload 0.02 C) are also available:

- with zinc-iron coating and yellow chromating (part numbers 16...4-30),
- with low friction seals (part numbers 16...4-11).

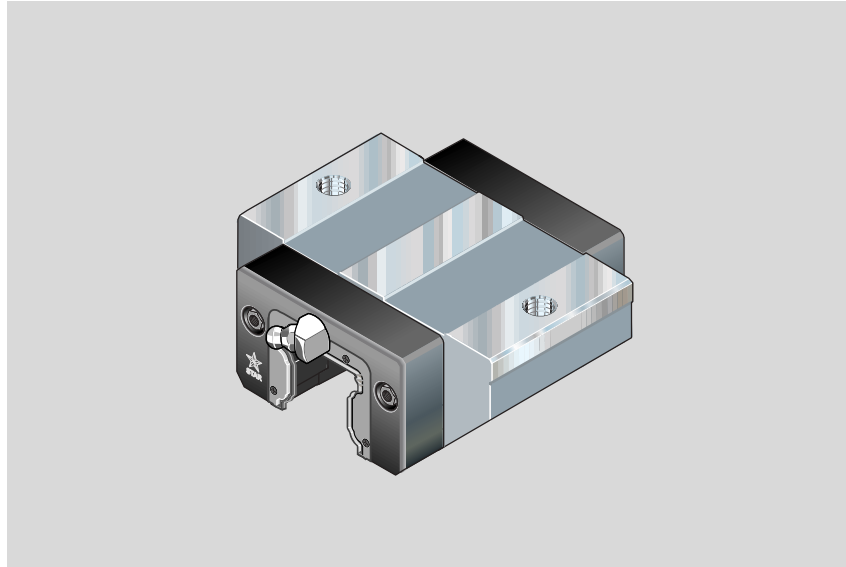

Part numbers

Size	Accuracy class	Part numbers for runner block for preload class	
		up to approx. 10 µm clearance	Preload 0.02 C
15	H	1665-193-10	1665-113-10
	N	1665-194-10	1665-114-10
20	H	1665-893-10	1665-813-10
	N	1665-894-10	1665-814-10
25	H	1665-293-10	1665-213-10
	N	1665-294-10	1665-214-10
30	H	1665-793-10	1665-713-10
	N	1665-794-10	1665-714-10
35	H	1665-393-10	1665-313-10
	N	1665-394-10	1665-314-10

Note on dynamic load capacities and moments (see table)

Determination of dynamic load capacities and moments is based on a travel life of 100,000 m.

For comparison with the 50,000 m travel sometimes applied for rail-type guideways, the figures for C , M_t and M_l in the table should be multiplied by 1.26.



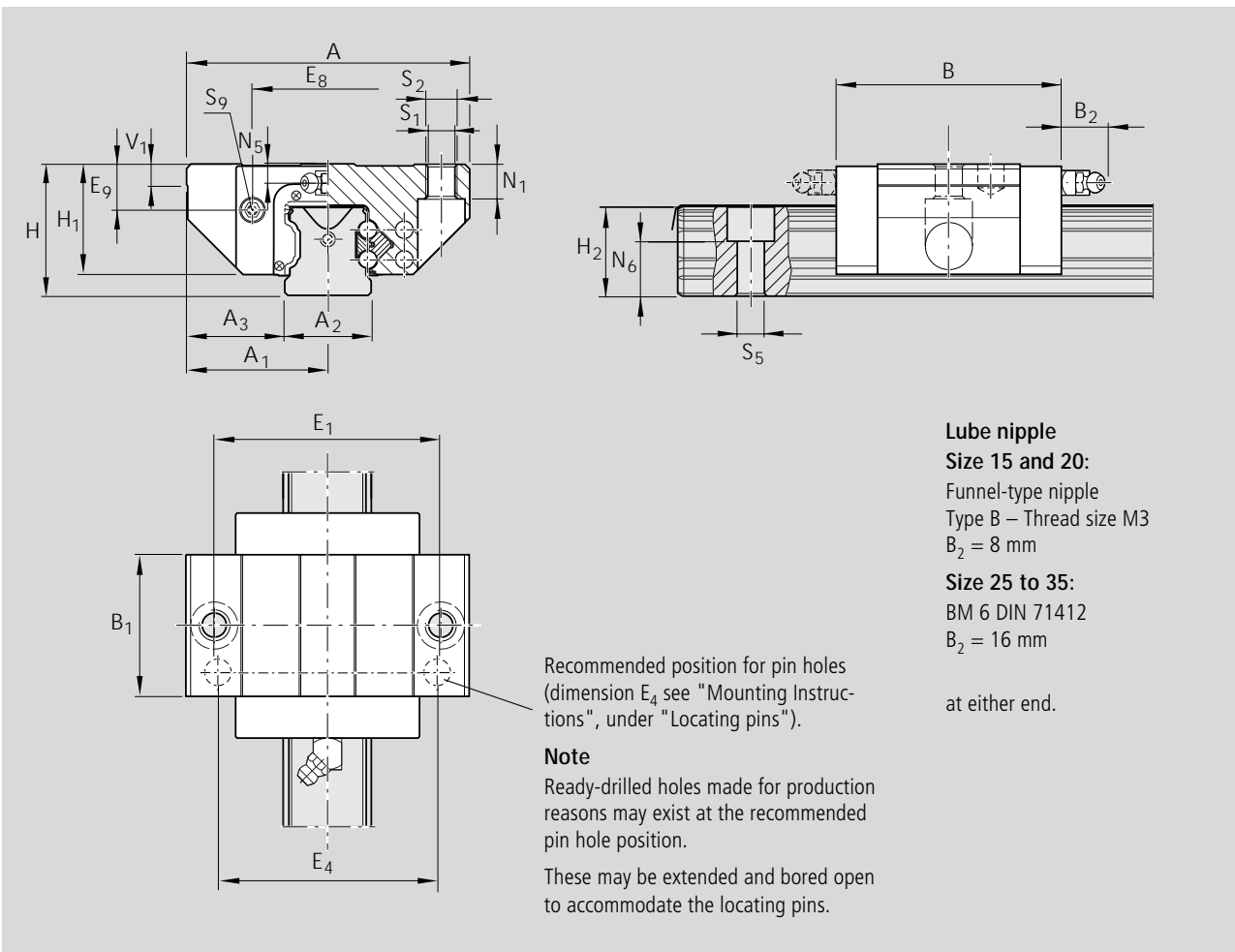

Size	Dimensions (mm)															
	A	A ₁	A ₂	A ₃	B	B ₁	H	H ₁	H ₂ ¹⁾	H ₂ ²⁾	V ₁	E ₁	E ₈	E ₉	N ₁	
15	47	23.5	15	16.0	40.5	25.7	24	19.8	16.3	16.20	5.0	38	24.55	6.7	5.0	
20	63	31.5	20	21.5	52.5	31.9	30	25.4	20.7	20.55	6.0	53	32.4	7.3	7.5	
25	70	35.0	23	23.5	61.5	38.6	36	29.5	24.4	24.25	7.5	57	38.3	11.5	9.0	
30	90	45.0	28	31.0	71.5	45.0	42	35.0	28.5	28.35	7.0	72	48.4	14.6	11.0	
35	100	50.0	34	33.0	79.0	51.4	48	40.0	32.15	31.85	8.0	82	58.0	17.5	12.0	

1) Dimension H₂ with Rail Seal[®] cover strip 2) Dimension H₂ without Rail Seal[®] cover strip

Size	Dimensions (mm)						Mass (kg)	Load capacities (N)		Moments (Nm)			
	N ₅	N ₆ ^{±0.5}	S ₁	S ₂	S ₅	S ₉		C dyn.	C ₀ stat.	M _t dyn.	M _{t0} stat.	M _L dyn.	M _{L0} stat.
15	4.0	10.3	4.4	M5	4.4	M2.5-3.5 deep	0.19	5 400	8 100	52	80	19	28
20	4.7	13.2	5.4	M6	6.0	M3-5 deep	0.43	12 400	13 600	150	170	52	58
25	5.5	15.2	6.8	M8	7.0	M3-5 deep	0.50	15 900	18 200	230	260	82	94
30	6.0	17.0	8.6	M10	9.0	M3-5 deep	0.90	22 100	24 800	380	430	133	150
35	7.0	20.5	8.6	M10	9.0	M3-5 deep	1.35	29 300	32 400	640	700	200	220

30% higher dynamic load capacities and moments



STAR – Ball Rail® Systems

Runner Blocks, Steel Version

Runner Block 1651-

Standard width

Special versions:

Runner blocks in accuracy class N (clearance and preload 0.02 C) are also available:

- with zinc-iron coating and yellow chromating (part numbers 16...-4-30),
- with low friction seals (part numbers 16...-4-11).

Size 15 to 35 in accuracy class H (clearance and preload 0.02 C) also available as low noise runner blocks with spacer balls.

Dynamic load capacities and moments are reduced by 35%.
(Part numbers 1651...3-12)

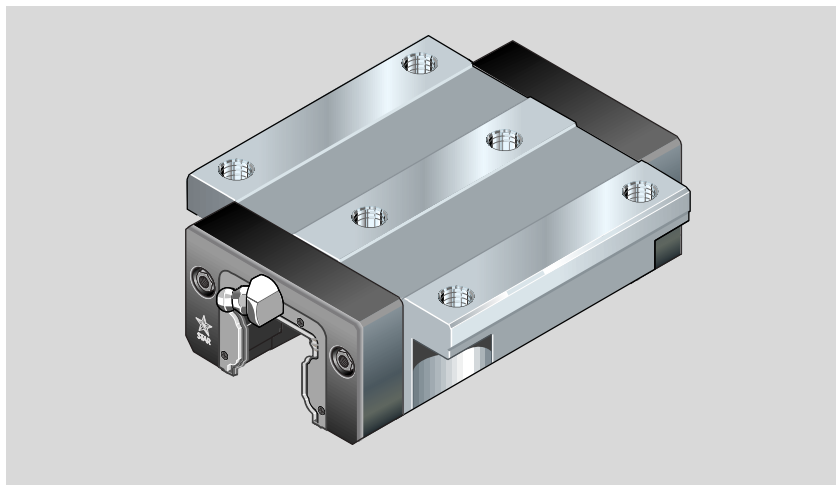

Part numbers

* 30% higher dynamic load capacities on request

Size	Accuracy class	Part numbers for runner blocks for preload class			
		up to approx. 10 µm clearance	Preload 0.02 C	Preload 0.08 C	Preload 0.13 C
15	UP		1651-119-10*	1651-129-10*	1651-139-10*
	SP		1651-111-10*	1651-121-10*	1651-131-10*
20	P		1651-112-10	1651-122-10	1651-132-10
	H	1651-193-10	1651-113-10	1651-123-10	
	N	1651-194-10	1651-114-10	1651-124-10	
	UP		1651-819-10*	1651-829-10*	1651-839-10*
25	SP		1651-811-10*	1651-821-10*	1651-831-10*
	P		1651-812-10	1651-822-10	1651-832-10
	H	1651-893-10	1651-813-10	1651-823-10	
	N	1651-894-10	1651-814-10	1651-824-10	
30	UP		1651-219-10*	1651-229-10*	1651-239-10*
	SP		1651-211-10*	1651-221-10*	1651-231-10*
	P		1651-212-10	1651-222-10	1651-232-10
	H	1651-293-10	1651-213-10	1651-223-10	
35	N	1651-294-10	1651-214-10	1651-224-10	
	UP		1651-719-10*	1651-729-10*	1651-739-10*
	SP		1651-711-10*	1651-721-10*	1651-731-10*
	P		1651-712-10	1651-722-10	1651-732-10
45	H	1651-793-10	1651-713-10	1651-723-10	
	N	1651-794-10	1651-714-10	1651-724-10	
	UP		1651-319-10*	1651-329-10*	1651-339-10*
	SP		1651-311-10*	1651-321-10*	1651-331-10*
55	P		1651-312-10	1651-322-10	1651-332-10
	H	1651-393-10	1651-313-10	1651-323-10	
	N	1651-394-10	1651-314-10	1651-324-10	
	UP		1651-419-10*	1651-429-10*	1651-439-10*
65	SP		1651-411-10*	1651-421-10*	1651-431-10*
	P		1651-412-10	1651-422-10	1651-432-10
	H	1651-493-10	1651-413-10	1651-423-10	
	N	1651-494-10	1651-414-10	1651-424-10	
75	UP		1651-519-10*	1651-529-10*	1651-539-10*
	SP		1651-511-10*	1651-521-10*	1651-531-10*
	P		1651-512-10*	1651-522-10*	1651-532-10*
	H	1651-593-10*	1651-513-10*	1651-523-10*	
85	N	1651-594-10*	1651-514-10*	1651-524-10*	
	UP		1651-619-10*	1651-629-10*	1651-639-10*
	SP		1651-611-10*	1651-621-10*	1651-631-10*
	P		1651-612-10*	1651-622-10*	1651-632-10*
95	H	1651-693-10*	1651-613-10*	1651-623-10*	
	N	1651-694-10*	1651-614-10*	1651-624-10*	

Note on dynamic load capacities and moments (see table)

Determination of dynamic load capacities and moments is based on a travel life of 100,000 m.

For comparison with the 50,000 m travel sometimes applied for rail-type guideways, the figures for C , M_t and M_l in the table should be multiplied by 1.26.



Recommended position for pin holes (dimension E_4 see "Mounting Instructions", under "Locating pins").

Note
Ready-drilled holes made for production reasons may exist at the recommended pin hole position. These may be extended and bored open to accommodate the locating pins.

Lube nipple
Size 15 and 20:
 Funnel-type nipple
 Type B – Thread size M3
 $B_2 = 8$ mm
Size 25 to 55:
 BM 6 DIN 71412
 $B_2 = 16$ mm
Size 65:
 BM 8 x 1 DIN 71412
 $B_2 = 16$ mm
 at either end.

Size	Dimensions (mm)	
	$E_{8.1}$	$E_{9.1}$
65	100	53.5

Size 65

Size	Dimensions (mm)																	
	A	A ₁	A ₂	A ₃	B	B ₁	H	H ₁	H ₂ ¹⁾	H ₂ ²⁾	V ₁	E ₁	E ₂	E ₃	E ₈	E ₉	N ₁	N ₂
15	47	23.5	15	16.0	54	39.2	24	19.8	16.3	16.20	5.0	38	30	26	24.55	6.7	5.0	4.4
20	63	31.5	20	21.5	70	49.6	30	25.0	20.7	20.55	6.0	53	40	35	32.4	7.3	7.5	5.2
25	70	35.0	23	23.5	81	57.8	36	29.5	24.4	24.25	7.5	57	45	40	38.3	11.5	9.0	7.0
30	90	45.0	28	31.0	94	67.4	42	35.0	28.5	28.35	7.0	72	52	44	48.4	14.6	11.0	8.0
35	100	50.0	34	33.0	105	77.0	48	40.0	32.15	31.85	8.0	82	62	52	58.0	17.5	12.0	10.2
45	120	60.0	45	37.5	133	97.0	60	50.0	40.15	39.85	10.0	100	80	60	70.0	21.0	15.0	12.4
55	140	70.0	53	43.5	159	115.5	70	57.0	48.15	47.85	12.0	116	95	70	80.0	22.3	18.0	13.5
65	170	85.0	63	53.5	188	139.6	90	76.0	60.15	59.85	15.0	142	110	82	76.0	11.0	23.0	14.0

¹⁾ Dimension H₂ with Rail Seal® cover strip

²⁾ Dimension H₂ without Rail Seal® cover strip

Size	Dimensions (mm)							Mass (kg)	Load capacities (N)		Moments (Nm)			
	N ₅	N ₆ ^{±0.5}	S ₁	S ₂	S ₅	S ₉	C dyn.		C ₀ stat.	M _t dyn.	M _{t0} stat.	M _L dyn.	M _{L0} stat.	
15	4.0	10.3	4.4	M5	4.4	M2.5-3.5deep	0.23	7 800	13 500	74	130	40	71	
20	4.7	13.2	5.4	M6	6.0	M3-5deep	0.55	18 800	24 400	240	310	130	165	
25	5.5	15.2	6.8	M8	7.0	M3-5deep	0.70	22 800	30 400	320	430	180	240	
30	6.0	17.0	8.6	M10	9.0	M3-5deep	1.10	31 700	41 300	540	720	290	380	
35	7.0	20.5	8.6	M10	9.0	M3-5deep	1.75	41 900	54 000	890	1 160	440	565	
45	8.0	23.5	10.5	M12	14.0	M4-7deep	3.15	68 100	85 700	1 830	2 310	890	1 130	
55	9.0	29.0	12.5	M14	16.0	M5-8deep	5.20	98 200	121 400	3 100	3 860	1 540	1 905	
65	16.0	38.5	14.5	M16	18.0	M4-7deep	10.25	160 000	192 700	6 300	7 610	3 160	3 815	

30% higher dynamic load capacities and moments

STAR – Ball Rail® Systems Runner Blocks, Steel Version

Runner block 1653-

Standard width, long

Special versions:

Runner blocks in accuracy class N (clearance and preload 0.02 C) are also available:

- with zinc-iron coating and yellow chromating (part numbers 16...-4-30),
- with low friction seals (part numbers 16...-4-11).

Size 15 to 35 in accuracy class H (clearance and preload 0.02 C) also available as low noise runner blocks with spacer balls.

Dynamic load capacities and moments are reduced by 35%.

(Part numbers 1653...3-12)

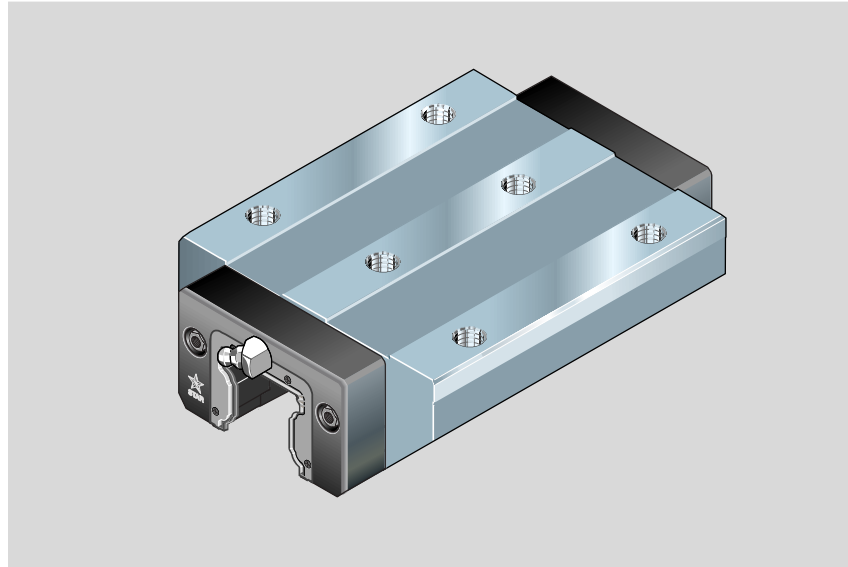

Part numbers

* 30% higher dynamic load capacities on request

Size	Accuracy class	Part numbers for runner blocks for preload class			
		up to approx. 10 µm clearance	Preload 0.02 C	Preload 0.08 C	Preload 0.13 C
15	N	1653-194-10	1653-114-10		
20	UP		1653-819-10*	1653-829-10*	1653-839-10*
	SP		1653-811-10*	1653-821-10*	1653-831-10*
	P		1653-812-10	1653-822-10	1653-832-10
	H	1653-893-10	1653-813-10	1653-823-10	
25	N	1653-894-10	1653-814-10	1653-824-10	
	UP		1653-219-10*	1653-229-10*	1653-239-10*
	SP		1653-211-10*	1653-221-10*	1653-231-10*
	P		1653-212-10	1653-222-10	1653-232-10
30	H	1653-293-10	1653-213-10	1653-223-10	
	N	1653-294-10	1653-214-10	1653-224-10	
	UP		1653-719-10*	1653-729-10*	1653-739-10*
	SP		1653-711-10*	1653-721-10*	1653-731-10*
35	P		1653-712-10	1653-722-10	1653-732-10
	H	1653-793-10	1653-713-10	1653-723-10	
	N	1653-794-10	1653-714-10	1653-724-10	
	UP		1653-319-10*	1653-329-10*	1653-339-10*
45	SP		1653-311-10*	1653-321-10*	1653-331-10*
	P		1653-312-10	1653-322-10	1653-332-10
	H	1653-393-10	1653-313-10	1653-323-10	
	N	1653-394-10	1653-314-10	1653-324-10	
55	UP		1653-419-10*	1653-429-10*	1653-439-10*
	SP		1653-411-10*	1653-421-10*	1653-431-10*
	P		1653-412-10	1653-422-10	1653-432-10
	H	1653-493-10	1653-413-10	1653-423-10	
65	N	1653-494-10	1653-414-10	1653-424-10	
	UP		1653-519-10*	1653-529-10*	1653-539-10*
	SP		1653-511-10*	1653-521-10*	1653-531-10*
	P		1653-512-10*	1653-522-10*	1653-532-10*
65	H	1653-593-10*	1653-513-10*	1653-523-10*	
	N	1653-594-10*	1653-514-10*	1653-524-10*	
	UP		1653-619-10*	1653-629-10*	1653-639-10*
	SP		1653-611-10*	1653-621-10*	1653-631-10*
65	P		1653-612-10*	1653-622-10*	1653-632-10*
	H	1653-693-10*	1653-613-10*	1653-623-10*	
	N	1653-694-10*	1653-614-10*	1653-624-10*	

Note on dynamic load capacities and moments (see table)

Determination of dynamic load capacities and moments is based on a travel life of 100,000 m.

For comparison with the 50,000 m travel sometimes applied for rail-type guideways, the figures for C , M_t and M_L in the table should be multiplied by 1.26.



Lube nipple
Size 20:
 Funnel-type nipple
 Type B – Thread size M3
 $B_2 = 8 \text{ mm}$
Size 25 to 55:
 BM 6 DIN 71412
 $B_2 = 16 \text{ mm}$
Size 65:
 BM 8 x 1 DIN 71412
 $B_2 = 16 \text{ mm}$
 at either end.

Recommended position for pin holes (dimension E_4 see "Mounting Instructions", under "Locating pins").

Note
 Ready-drilled holes made for production reasons may exist at the recommended pin hole position. These may be extended and bored open to accommodate the locating pins.

Size	Dimensions (mm)	
	$E_{8.1}$	$E_{9.1}$
65	100	53.5

Size 65

Size	Dimensions (mm)																	
	A	A ₁	A ₂	A ₃	B	B ₁	H	H ₁	H ₂ ¹⁾	H ₂ ²⁾	V ₁	E ₁	E ₂	E ₃	E ₈	E ₉	N ₁	N ₂
15	47	23.5	15	16.0	68.5	53.6	24	19.8	16.3	16.20	5.0	38	30	26	24.55	6.7	5.0	4.4
20	63	31.5	20	21.5	86.0	65.6	30	25.0	20.7	20.55	6.0	53	40	35	32.4	7.3	7.5	5.2
25	70	35.0	23	23.5	103.0	79.5	36	29.5	24.4	24.25	7.5	57	45	40	38.3	11.5	9.0	7.0
30	90	45.0	28	31.0	116.0	89.4	42	35.0	28.5	28.35	7.0	72	52	44	48.4	14.6	11.0	8.0
35	100	50.0	34	33.0	133.0	105.5	48	40.0	32.15	31.85	8.0	82	62	52	58.0	17.5	12.0	10.2
45	120	60.0	45	37.5	170.0	133.5	60	50.0	40.15	39.85	10.0	100	80	60	70.0	21.0	15.0	12.4
55	140	70.0	53	43.5	200.0	155.5	70	57.0	48.15	47.85	12.0	116	95	70	80.0	22.3	18.0	13.5
65	170	85.0	63	53.5	243.0	194.6	90	76.0	60.15	59.85	15.0	142	110	82	76.0	11.0	23.0	14.0

¹⁾ Dimension H_2 with Rail Seal® cover strip

²⁾ Dimension H_2 without Rail Seal® cover strip

Size	Dimensions (mm)						Mass (kg)	Load capacities (N)		Moments (Nm)			
	N ₅	N ₆ ^{±0.5}	S ₁	S ₂	S ₅	S ₉		C dyn.	C ₀ stat.	M _t dyn.	M _{t0} stat.	M _L dyn.	M _{L0} stat.
15	4.0	10.3	4.4	M5	4.4	M2.5-3.5 deep	0.32	10 000	20 200	130	190	98	150
20	4.7	13.2	5.4	M6	6	M3-5 deep	0.80	24 400	35 200	310	450	225	330
25	5.5	15.2	6.8	M8	7	M3-5 deep	1.00	30 400	45 500	430	650	345	510
30	6.0	17.0	8.6	M10	9	M3-5 deep	1.60	40 000	57 800	690	1 000	495	715
35	7.0	20.5	8.6	M10	9	M3-5 deep	2.45	55 600	81 000	1 200	1 740	830	1 215
45	8.0	23.5	10.5	M12	14	M4-7 deep	4.50	90 400	128 500	2 440	3 470	1 700	2 425
55	9.0	29.0	12.5	M14	16	M5-8 deep	7.50	124 200	170 000	3 950	5 400	2 630	3 600
65	16.0	38.5	14.5	M16	18	M4-7 deep	14.15	211 900	289 000	8 370	11 420	6 000	8 190

30% higher dynamic load capacities and moments



STAR – Ball Rail® Systems

Runner Blocks, Steel Version

Runner block 1663-

Standard width, short, low profile

Special versions:

Runner blocks in accuracy class N (clearance and preload 0.02 C) are also available:

- with zinc-iron coating and yellow chromating (part numbers 16...4-30),
- with low friction seals (part numbers 16...4-11).

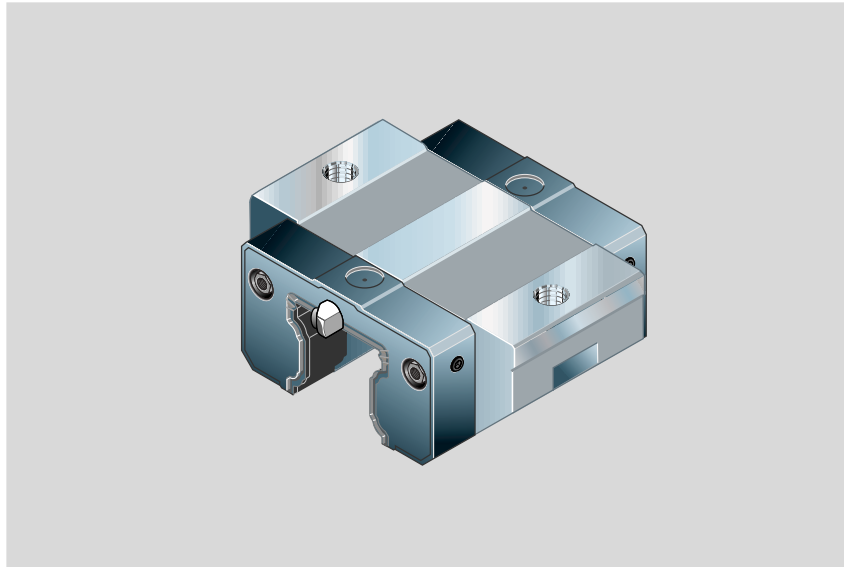

Part numbers

Size	Accuracy class	Part numbers for runner blocks for preload class	
		up to approx. 10 µm clearance	Preload 0.02 C
20	H	1663-893-10	1663-813-10
	N	1663-894-10	1663-814-10
25	H	1663-293-10	1663-213-10
	N	1663-294-10	1663-214-10

Note on dynamic load capacities and moments (see table)

Determination of dynamic load capacities and moments is based on a travel life of 100,000 m.

For comparison with the 50,000 m travel sometimes applied for rail-type guideways, the figures for C , M_t and M_L in the table should be multiplied by 1.26.

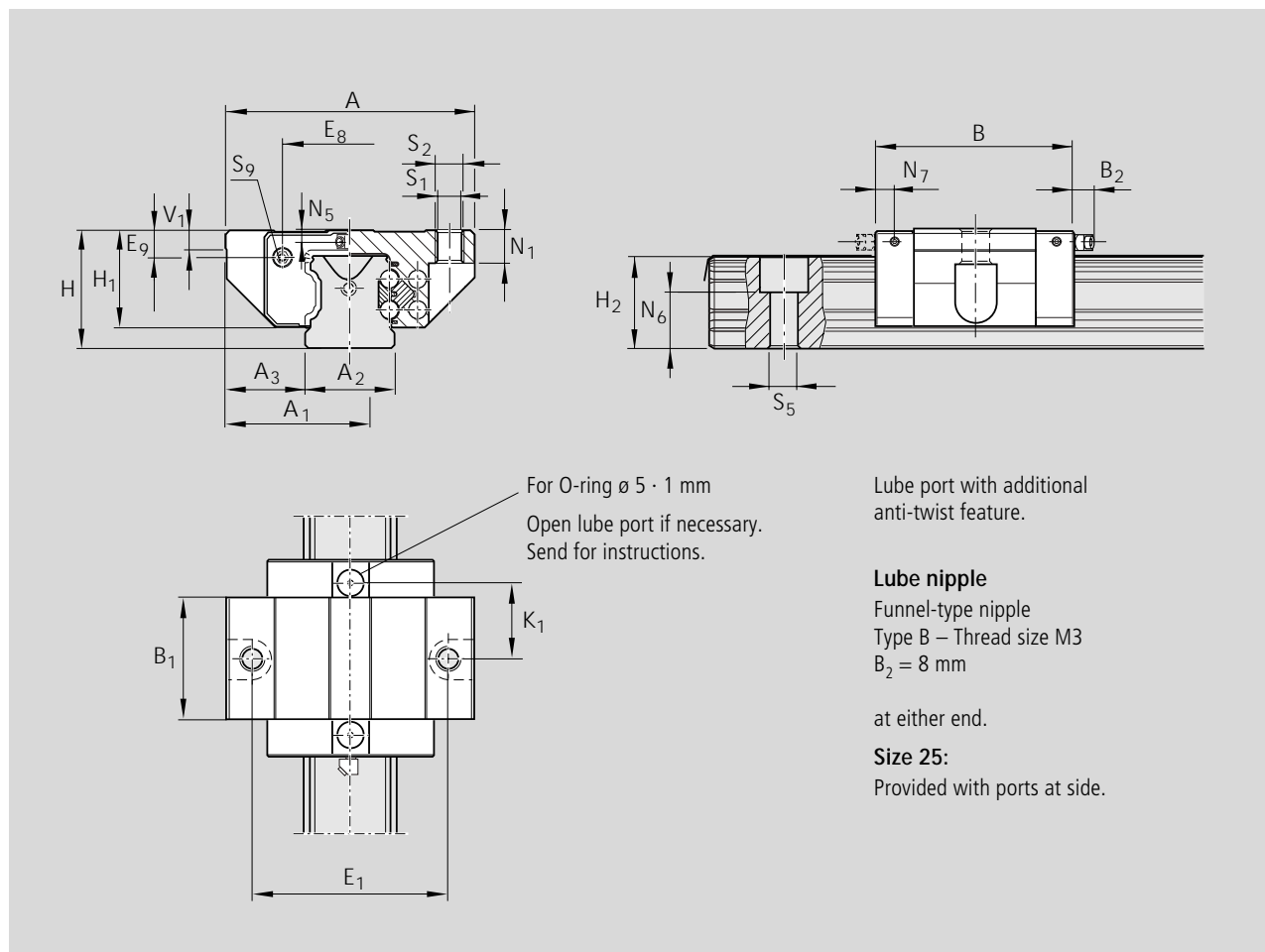

Dimensions (mm)																		
Size	A	A ₁	A ₂	A ₃	B	B ₁	H	H ₁	H ₂ ¹⁾	H ₂ ²⁾	V ₁	E ₁		E ₈	E ₉	K ₁	N ₁	N ₅
20	59	29.5	20	19.5	55	31.9	28	23.0	20.7	20.55	6.0	49		30.5	5.6	20.1	7.7	3.6
25	73	36.5	23	25.0	62	38.6	33	26.5	24.4	24.25	7.5	60		38.3	8.5	24.5	9.3	4.1

¹⁾ Dimension H₂ with Rail Seal® cover strip

²⁾ Dimension H₂ without Rail Seal® cover strip

Size	Dimensions (mm)							Mass (kg)	Load capacities (N)		Moments (Nm)			
	N ₆ ^{±0.5}	N ₇	S ₁	S ₂	S ₅	S ₉	C dyn.		C ₀ stat.	M _t dyn.	M _{t0} stat.	M _L dyn.	M _{L0} stat.	
20	13.2	–	5.4	M6	6.0	M3-5 deep	0.43	9 600	13 600	120	170	40	58	
25	15.2	6.0	6.8	M8	7.0	M3-5 deep	0.50	15 900*	18 200	235	260	82	94	

* 30% higher dynamic load capacity

STAR – Ball Rail® Systems

Runner Blocks, Steel Version

Runner block 1693-

Standard width, low profile

Special versions:

Runner blocks in accuracy class N (clearance and preload 0.02 C) are also available:

- with zinc-iron coating and yellow chromating (part numbers 16...4-30),
- with low friction seals (part numbers 16...4-11).

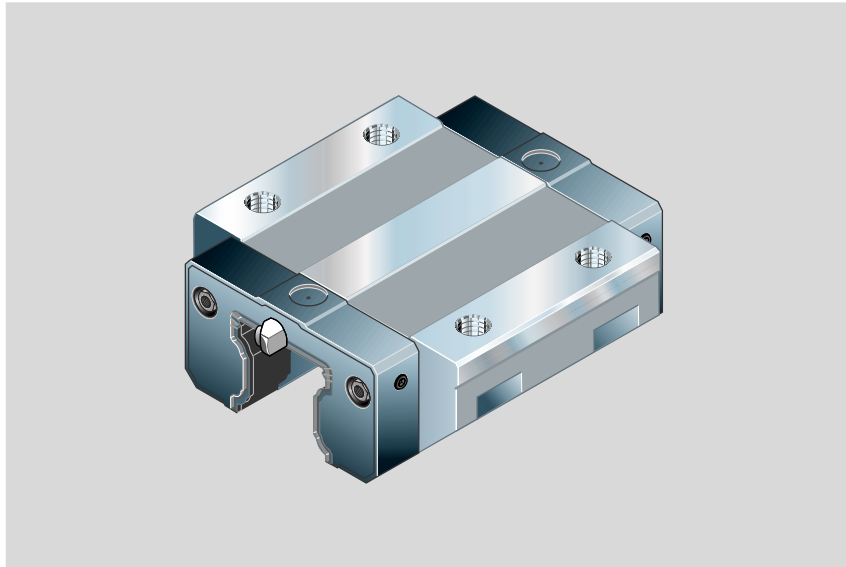

Part numbers

Size	Accuracy class	Part numbers for runner blocks for preload class	
		up to approx. 10 µm clearance	Preload 0.02 C
20	H	1693-893-10	1693-813-10
	N	1693-894-10	1693-814-10
25	H	1693-293-10	1693-213-10
	N	1693-294-10	1693-214-10

Note on dynamic load capacities and moments (see table)

Determination of dynamic load capacities and moments is based on a travel life of 100,000 m.

For comparison with the 50,000 m travel sometimes applied for rail-type guideways, the figures for C , M_t and M_L in the table should be multiplied by 1.26.



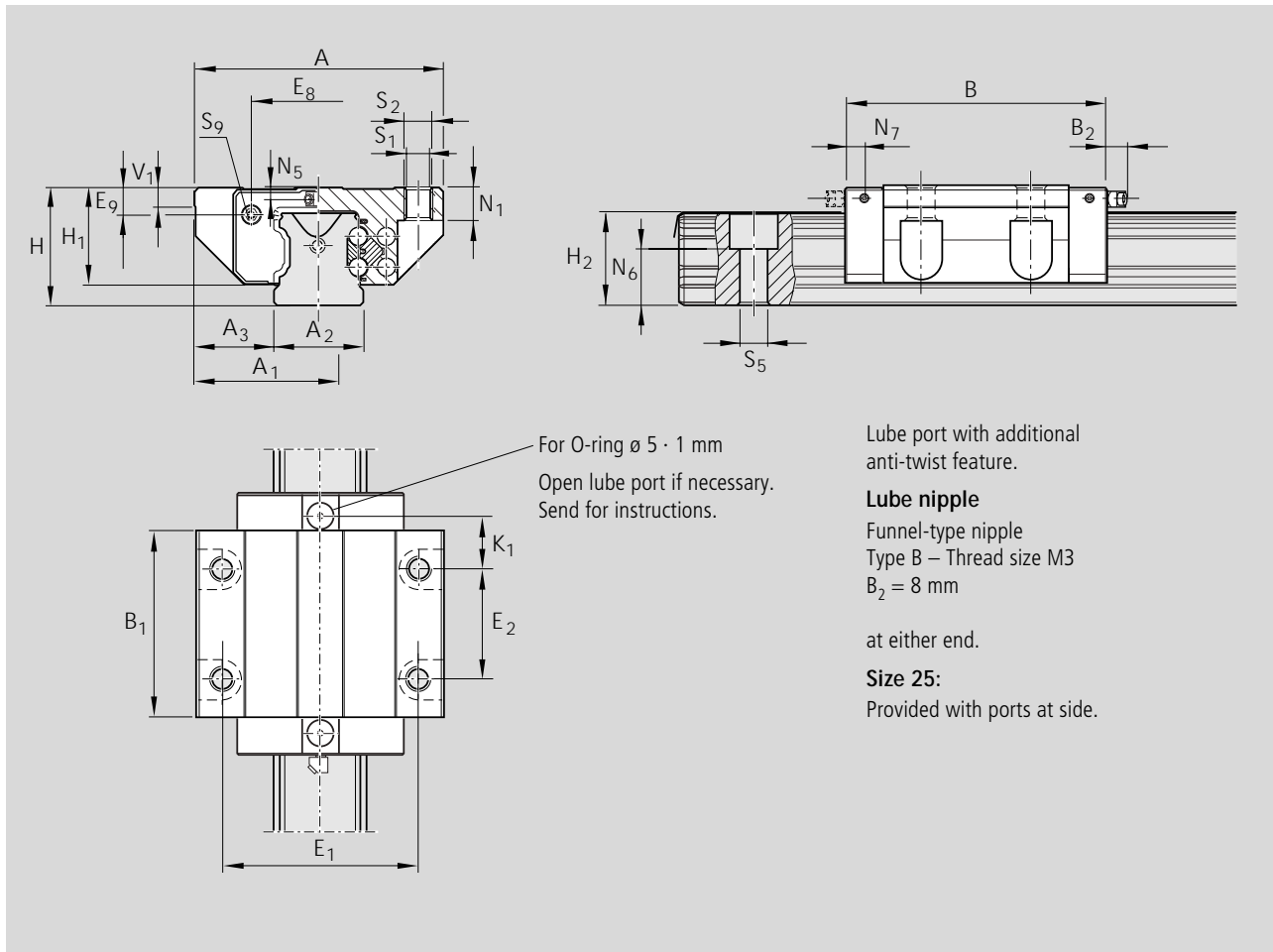

Size	Dimensions (mm)																	
	A	A ₁	A ₂	A ₃	B	B ₁	H	H ₁	H ₂ ¹⁾	H ₂ ²⁾	V ₁	E ₁	E ₂	E ₈	E ₉	K ₁	N ₁	N ₅
20	59	29.5	20	19.5	72.5	49.6	28	23.0	20.7	20.55	6.0	49	32	30.5	5.6	13.0	7.7	3.6
25	73	36.5	23	25.0	81.0	57.8	33	26.5	24.4	24.25	7.5	60	35	38.3	8.5	16.6	9.3	4.1

¹⁾ Dimension H₂ with Rail Seal® cover strip

²⁾ Dimension H₂ without Rail Seal® cover strip

Size	Dimensions (mm)							Mass (kg)	Load capacities (N)		Moments (Nm)			
	N ₆ ^{±0.5}	N ₇	S ₁	S ₂	S ₅	S ₉	C dyn.		C ₀ stat.	M _t dyn.	M _{t10} stat.	M _L dyn.	M _{L0} stat.	
	20	13.2	–	5.4	M6	6.0	M3-5 deep		0.50	14 500	24 400	190	310	100
25	15.2	6.0	6.8	M8	7.0	M3-5 deep	0.65	22 800*	30 400	320	430	180	240	

* 30% higher dynamic load capacity

STAR – Ball Rail® Systems

Runner Blocks, Steel Version

Runner block 1666-

Slimline, short

Special versions:

Runner blocks in accuracy class N (clearance and preload 0.02 C) are also available:

- with zinc-iron coating and yellow chromating (part numbers 16...4-30),
- with low friction seals (part numbers 16...4-11).

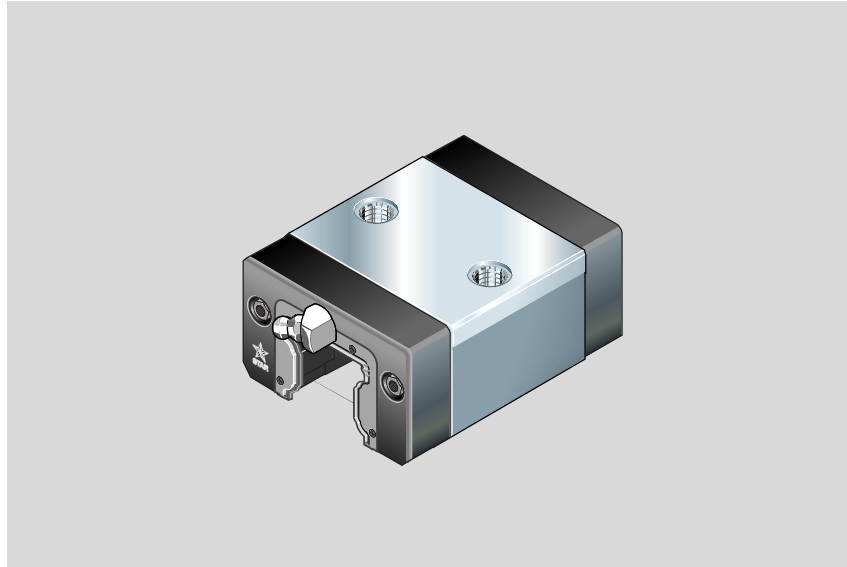

Part numbers

Size	Accuracy class	Part numbers for runner blocks for preload class	
		up to approx. 10 µm clearance	Preload 0.02 C
15	H	1666-193-10	1666-113-10
	N	1666-194-10	1666-114-10
20	H	1666-893-10	1666-813-10
	N	1666-894-10	1666-814-10
25	H	1666-293-10	1666-213-10
	N	1666-294-10	1666-214-10
30	H	1666-793-10	1666-713-10
	N	1666-794-10	1666-714-10
35	H	1666-393-10	1666-313-10
	N	1666-394-10	1666-314-10

Note on dynamic load capacities and moments (see table)

Determination of dynamic load capacities and moments is based on a travel life of 100,000 m.

For comparison with the 50,000 m travel sometimes applied for rail-type guideways, the figures for C , M_t and M_L in the table should be multiplied by 1.26.



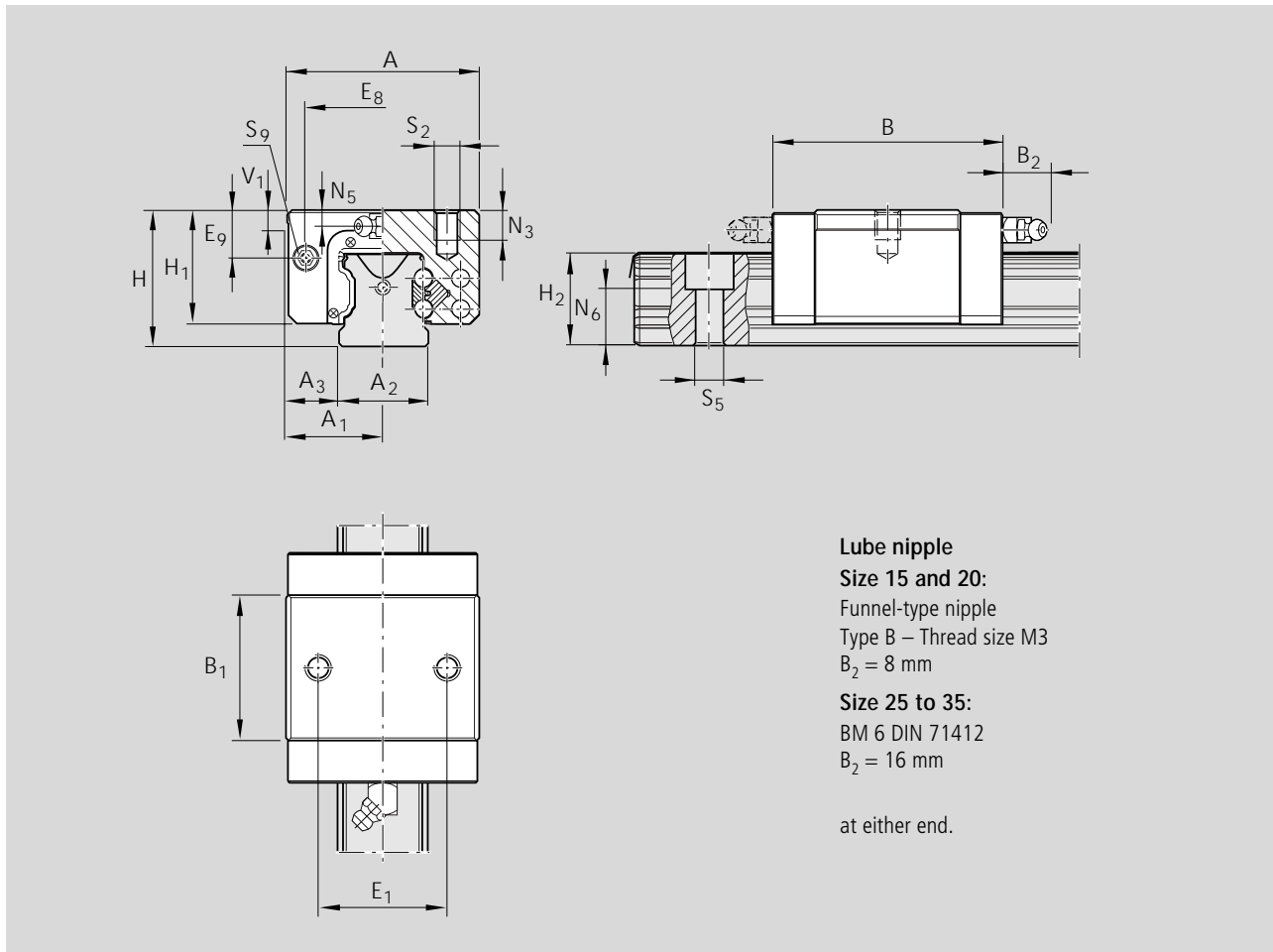

Size	Dimensions (mm)														
	A	A ₁	A ₂	A ₃	B	B ₁	H	H ₁	H ₂ ¹⁾	H ₂ ²⁾	V ₁	E ₁	E ₈	E ₉	N ₃
15	34	17	15	9.5	40.5	25.7	24	19.8	16.3	16.20	5.0	26	24.55	6.7	6.0
20	44	22	20	12.0	52.5	31.9	30	25.4	20.7	20.55	6.0	32	32.4	7.3	7.5
25	48	24	23	12.5	61.5	38.6	36	29.5	24.4	24.25	7.5	35	38.3	11.5	9.0
30	60	30	28	16.0	71.5	45.0	42	35.0	28.5	28.35	7.0	40	48.4	14.6	12.0
35	70	35	34	18.0	79.0	51.4	48	40.0	32.15	31.85	8.0	50	58.0	17.5	13.0

1) Dimension H₂ with Rail Seal® cover strip

2) Dimension H₂ without Rail Seal® cover strip

Size	Dimensions (mm)						Mass (kg)	Load capacities (N)		Moments (Nm)			
	N ₅	N ₆ ^{±0.5}	S ₂	S ₅	S ₉	C dyn.		C ₀ stat.	M _t dyn.	M _{t0} stat.	M _L dyn.	M _{L0} stat.	
15	4.0	10.3	M4	4.4	M2.5-3.5 deep	0.12	5 400	8 100	52	80	19	28	
20	4.7	13.2	M5	6.0	M3-5 deep	0.30	12 400	13 600	150	170	52	58	
25	5.5	15.2	M6	7.0	M3-5 deep	0.40	15 900	18 200	230	260	82	94	
30	6.0	17.0	M8	9.0	M3-5 deep	0.65	22 100	24 800	380	430	133	150	
35	7.0	20.5	M8	9.0	M3-5 deep	0.95	29 300	32 400	640	700	200	220	

30% higher dynamic load capacities and moments



STAR – Ball Rail® Systems

Runner Blocks, Steel Version

Runner block 1622-

Slimline

Special versions:

Runner blocks in accuracy class N (clearance and preload 0.02 C) are also available:

- with zinc-iron coating and yellow chromating (part numbers 16...-4-30),
- with low friction seals (part numbers 16...-4-11).

Size 15 to 35 in accuracy class H (clearance and preload 0.02 C) also available as low noise runner blocks with spacer balls.

Dynamic load capacities and moments are reduced by 35%.

(Part numbers 1622...-3-12)

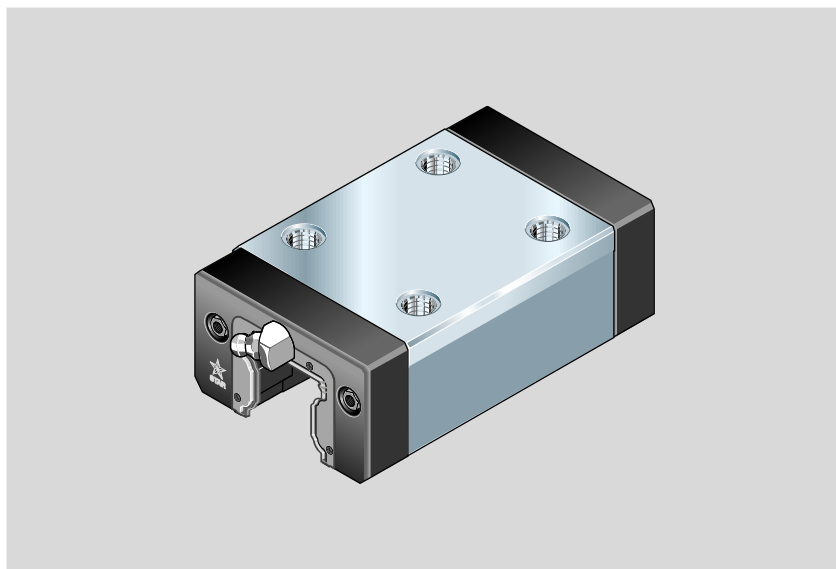

Part numbers

* 30% higher dynamic load capacities on request

Size	Accuracy class	Part numbers for runner blocks for preload class			
		up to approx. 10 µm clearance	Preload 0.02 C	Preload 0.08 C	Preload 0.13 C
15	P		1622-112-10	1622-122-10	1622-132-10
	H	1622-193-10	1622-113-10	1622-123-10	
	N	1622-194-10	1622-114-10	1622-124-10	
20	P		1622-812-10	1622-822-10	1622-832-10
	H	1622-893-10	1622-813-10	1622-823-10	
	N	1622-894-10	1622-814-10	1622-824-10	
25	P		1622-212-10	1622-222-10	1622-232-10
	H	1622-293-10	1622-213-10	1622-223-10	
	N	1622-294-10	1622-214-10	1622-224-10	
30	P		1622-712-10	1622-722-10	1622-732-10
	H	1622-793-10	1622-713-10	1622-723-10	
	N	1622-794-10	1622-714-10	1622-724-10	
35	P		1622-312-10	1622-322-10	1622-332-10
	H	1622-393-10	1622-313-10	1622-323-10	
	N	1622-394-10	1622-314-10	1622-324-10	
45	P		1622-412-10	1622-422-10	1622-432-10
	H	1622-493-10	1622-413-10	1622-423-10	
	N	1622-494-10	1622-414-10	1622-424-10	
55	P		1622-512-10*	1622-522-10*	1622-532-10*
	H	1622-593-10*	1622-513-10*	1622-523-10*	
	N	1622-594-10*	1622-514-10*	1622-524-10*	
65	P		1622-612-10*	1622-622-10*	1622-632-10*
	H	1622-693-10*	1622-613-10*	1622-623-10*	
	N	1622-694-10*	1622-614-10*	1622-624-10*	

Note on dynamic load capacities and moments (see table)

Determination of dynamic load capacities and moments is based on a travel life of 100,000 m.

For comparison with the 50,000 m travel sometimes applied for rail-type guideways, the figures for C , M_t and M_L in the table should be multiplied by 1.26.



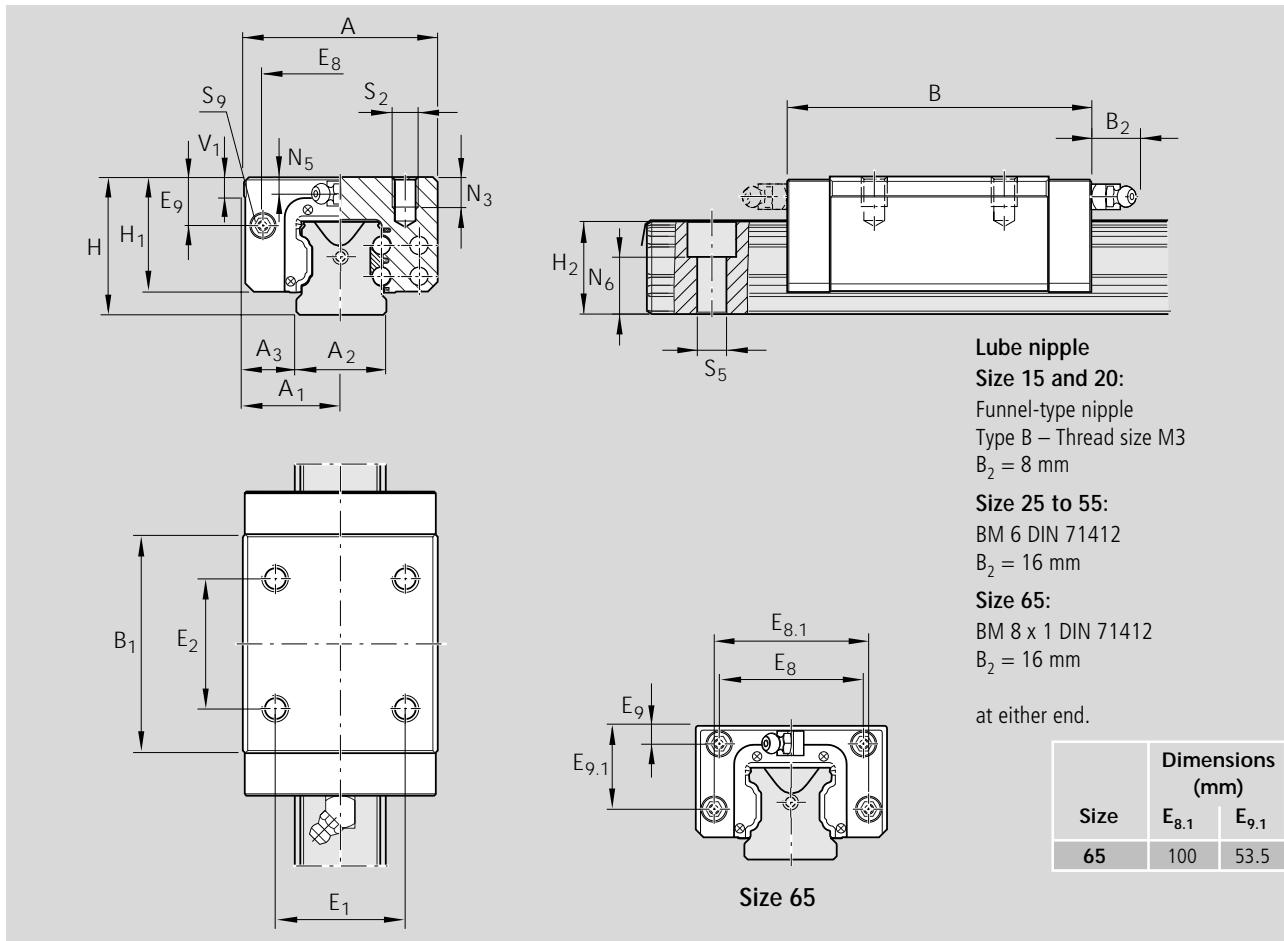

Size	Dimensions (mm)	
	E _{8.1}	E _{9.1}
65	100	53.5

Size	Dimensions (mm)																
	A	A ₁	A ₂	A ₃	B	B ₁	H	H ₁	H ₂ ¹⁾	H ₂ ²⁾	V ₁	E ₁	E ₂	E ₈	E ₉	N ₃	
15	34	17	15	9.5	54	39.2	24	19.8	16.3	16.20	5.0	26	26	24.55	6.7	6.0	
20	44	22	20	12.0	70	49.6	30	25.4	20.7	20.55	6.0	32	36	32.4	7.3	7.5	
25	48	24	23	12.5	81	57.8	36	29.5	24.4	24.25	7.5	35	35	38.3	11.5	9.0	
30	60	30	28	16.0	94	67.4	42	35.0	28.5	28.35	7.0	40	40	48.4	14.6	12.0	
35	70	35	34	18.0	105	77.0	48	40.0	32.15	31.85	8.0	50	50	58.0	17.5	13.0	
45	86	43	45	20.5	133	97.0	60	50.0	40.15	39.85	10.0	60	60	70.0	21.0	18.0	
55	100	50	53	23.5	159	115.5	70	57.0	48.15	47.85	12.0	75	75	80.0	22.3	19.0	
65	126	63	63	31.5	188	139.6	90	76.0	60.15	59.85	15.0	76	70	76.0	11.0	21.0	

¹⁾ Dimension H₂ with Rail Seal® cover strip

²⁾ Dimension H₂ without Rail Seal® cover strip

Size	Dimensions (mm)						Mass (kg)	Load capacities (N)		Moments (Nm)			
	N ₅	N ₆ ^{±0.5}	S ₂	S ₅	S ₉	C dyn.		C ₀ stat.	M _t dyn.	M _{t0} stat.	M _L dyn.	M _{L0} stat.	
15	4.0	10.3	M4	4.4	M2.5-3.5 deep	0.15	7 800	13 500	74	130	40	71	
20	4.7	13.2	M5	6.0	M3-5 deep	0.40	18 800	24 400	240	310	130	165	
25	5.5	15.2	M6	7.0	M3-5 deep	0.55	22 800	30 400	320	430	180	240	
30	6.0	17.0	M8	9.0	M3-5 deep	0.90	31 700	41 300	540	720	290	380	
35	7.0	20.5	M8	9.0	M3-5 deep	1.20	41 900	54 000	890	1 160	440	565	
45	8.0	23.5	M10	14.0	M4-7 deep	2.30	68 100	85 700	1 830	2 310	890	1 130	
55	9.0	29.0	M12	16.0	M5-8 deep	3.80	98 200	121 400	3 100	3 860	1 540	1 905	
65	16.0	38.5	M16	18.0	M4-7 deep	6.90	160 000	192 700	6 300	7 610	3 160	3 815	

30% higher dynamic load capacities and moments

STAR – Ball Rail® Systems

Runner Blocks, Steel Version

Runner block 1623-

Slimline, long

Special versions:

Runner blocks in accuracy class N (clearance and preload 0.02 C) are also available:

- with zinc-iron coating and yellow chromating (part numbers 16...4-30),
- with low friction seals (part numbers 16...4-11).

Size 15 to 35 in accuracy class H (clearance and preload 0.02 C) also available as low noise runner blocks with spacer balls.

Dynamic load capacities and moments are reduced by 35%.

(Part numbers 1623-...3-12)

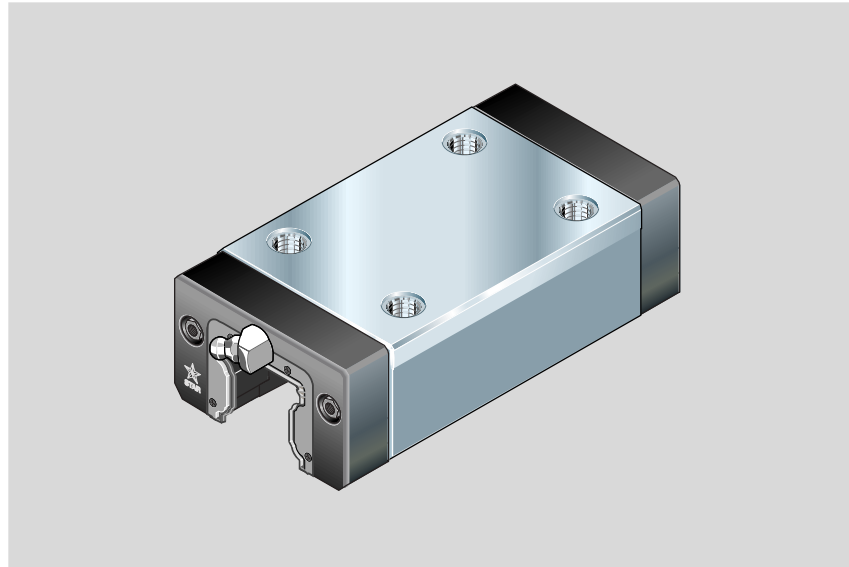

Part numbers

* 30% higher dynamic load capacities on request

Size	Accuracy class	Part numbers for runner blocks for preload class			
		up to approx. 10 µm clearance	Preload 0.02 C	Preload 0.08 C	Preload 0.13 C
15	N	1623-194-10	1623-114-10		
	P		1623-812-10	1623-822-10	1623-832-10
		H	1623-893-10	1623-813-10	1623-823-10
20	N	1623-894-10	1623-814-10	1623-824-10	
	P		1623-212-10	1623-222-10	1623-232-10
		H	1623-293-10	1623-213-10	1623-223-10
25	N	1623-294-10	1623-214-10	1623-224-10	
	P		1623-712-10	1623-722-10	1623-732-10
		H	1623-793-10	1623-713-10	1623-723-10
30	N	1623-794-10	1623-714-10	1623-724-10	
	P		1623-312-10	1623-322-10	1623-332-10
		H	1623-393-10	1623-313-10	1623-323-10
35	N	1623-394-10	1623-314-10	1623-324-10	
	P		1623-412-10	1623-422-10	1623-432-10
		H	1623-493-10	1623-413-10	1623-423-10
45	N	1623-494-10	1623-414-10	1623-424-10	
	P		1623-512-10*	1623-522-10*	1623-532-10*
		H	1623-593-10*	1623-513-10*	1623-523-10*
55	N	1623-594-10*	1623-514-10*	1623-524-10*	
	P		1623-612-10*	1623-622-10*	1623-632-10*
		H	1623-693-10*	1623-613-10*	1623-623-10*
65	N	1623-694-10*	1623-614-10*	1623-624-10*	

Note on dynamic load capacities and moments (see table)

Determination of dynamic load capacities and moments is based on a travel life of 100,000 m.

For comparison with the 50,000 m travel sometimes applied for rail-type guideways, the figures for C , M_t and M_L in the table should be multiplied by 1.26.



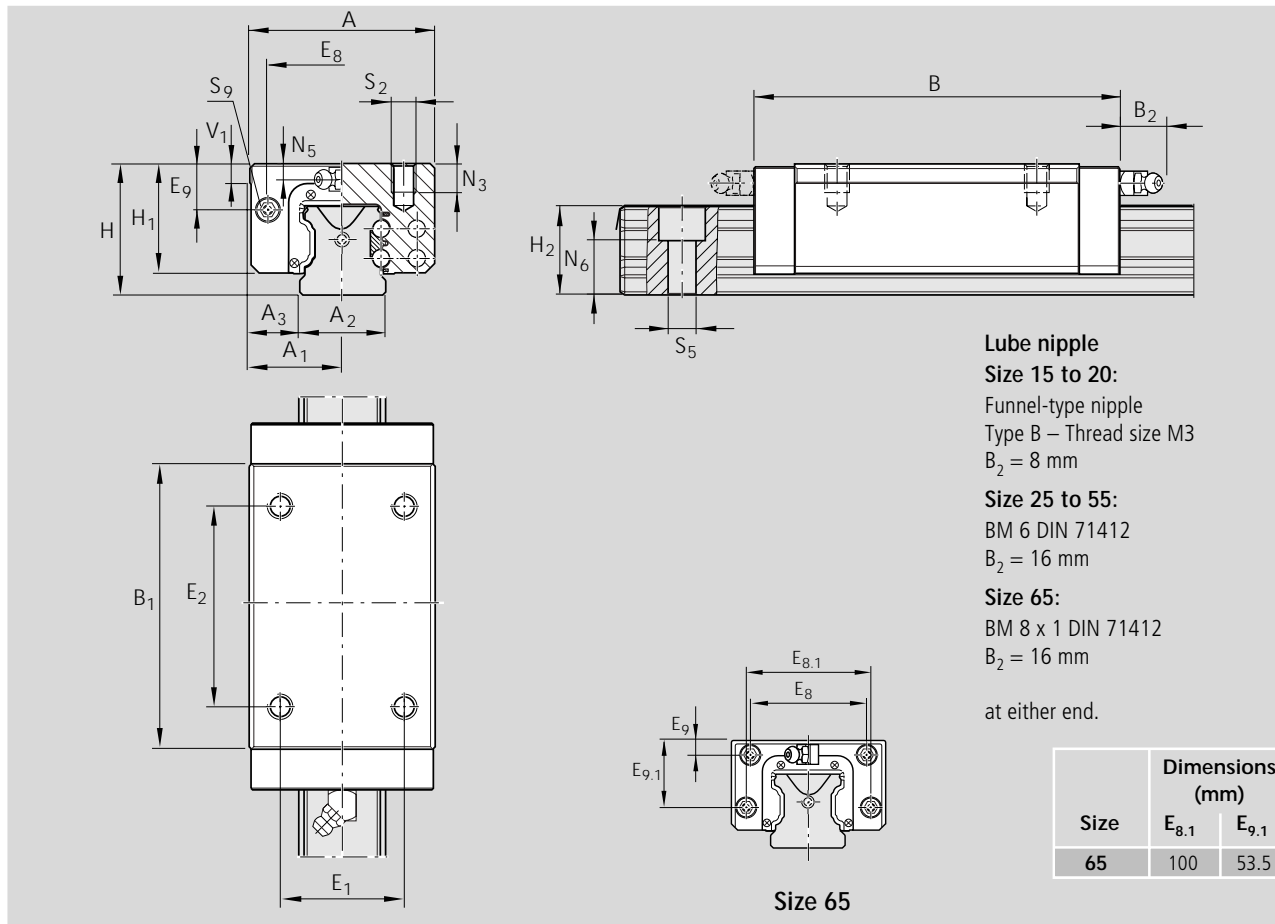

Size	Dimensions (mm)															
	A	A ₁	A ₂	A ₃	B	B ₁	H	H ₁	H ₂ ¹⁾	H ₂ ²⁾	V ₁	E ₁	E ₂	E ₈	E ₉	N ₃
15	34	17	15	9.5	68.5	53.6	24	19.8	16.3	16.2	5.0	26	26	24.55	6.7	6.0
20	44	22	20	12.0	86.0	65.6	30	25.4	20.7	20.55	6.0	32	50	32.4	7.3	7.5
25	48	24	23	12.5	103.0	79.5	36	29.5	24.4	24.25	7.5	35	50	38.3	11.5	9.0
30	60	30	28	16.0	116.0	89.4	42	35.0	28.5	28.35	7.0	40	60	48.4	14.6	12.0
35	70	35	34	18.0	133.0	105.5	48	40.0	32.15	31.85	8.0	50	72	58.0	17.5	13.0
45	86	43	45	20.5	170.0	133.5	60	50.0	40.15	39.85	10.0	60	80	70.0	21.0	18.0
55	100	50	53	23.5	200.0	155.5	70	57.0	48.15	47.85	12.0	75	95	80.0	22.3	19.0
65	126	63	63	31.5	243.0	194.6	90	76.0	60.15	59.85	15.0	76	120	76.0	11.0	21.0

1) Dimension H₂ with Rail Seal® cover strip

2) Dimension H₂ without Rail Seal® cover strip

Size	Dimensions (mm)						Mass (kg)	Load capacities (N)				Moments (Nm)	
	N ₅	N ₆ ^{±0.5}	S ₂	S ₅	S ₉	C dyn.		C ₀ stat.	M _t dyn.	M _{t0} stat.	M _L dyn.	M _{L0} stat.	
15	4.0	10.3	M4	4.4	M2.5-3.5 deep	0.2	10 000	20 200	130	190	98	150	
20	4.7	13.2	M5	6.0	M3-5 deep	0.5	24 400	35 200	310	450	225	330	
25	5.5	15.2	M6	7.0	M3-5 deep	0.7	30 400	45 500	430	650	345	510	
30	6.0	17.0	M8	9.0	M3-5 deep	1.1	40 000	57 800	690	1 000	495	715	
35	7.0	20.5	M8	9.0	M3-5 deep	1.7	55 600	81 000	1 200	1 740	830	1 215	
45	8.0	23.5	M10	14.0	M4-7 deep	3.1	90 400	128 500	2 440	3 470	1 700	2 425	
55	9.0	29.2	M12	16.0	M5-8 deep	4.8	124 200	170 000	3 950	5 400	2 630	3 600	
65	16.0	38.5	M16	18.0	M4-7 deep	9.8	211 900	289 000	8 370	11 420	6 000	8 190	

30% higher dynamic load capacities and moments

STAR – Ball Rail® Systems

Runner Blocks, Steel Version

Runner block 1664-

Slimline, short, low profile

Special versions:

Runner blocks in accuracy class N (clearance and preload 0.02 C) are also available:

- with zinc-iron coating and yellow chromating (part numbers 16...4-30),
- with low friction seals (part numbers 16...4-11).

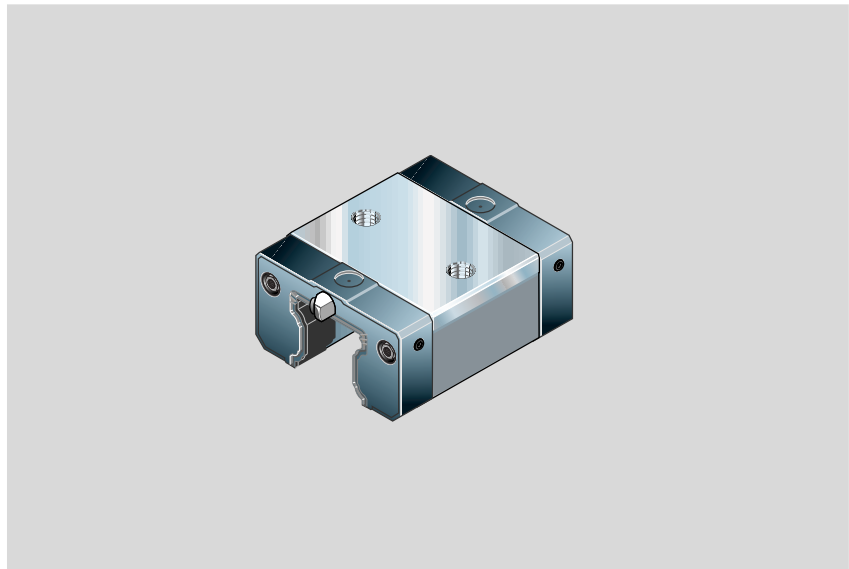

Part numbers

Size	Accuracy class	Part numbers for runner blocks for preload class	
		up to approx. 10 µm clearance	Preload 0.02 C
20	H	1664-893-10	1664-813-10
	N	1664-894-10	1664-814-10
25	H	1664-293-10	1664-213-10
	N	1664-294-10	1664-214-10

Note on dynamic load capacities and moments (see table)

Determination of dynamic load capacities and moments is based on a travel life of 100,000 m.

For comparison with the 50,000 m travel sometimes applied for rail-type guideways, the figures for C , M_t and M_L in the table should be multiplied by 1.26.



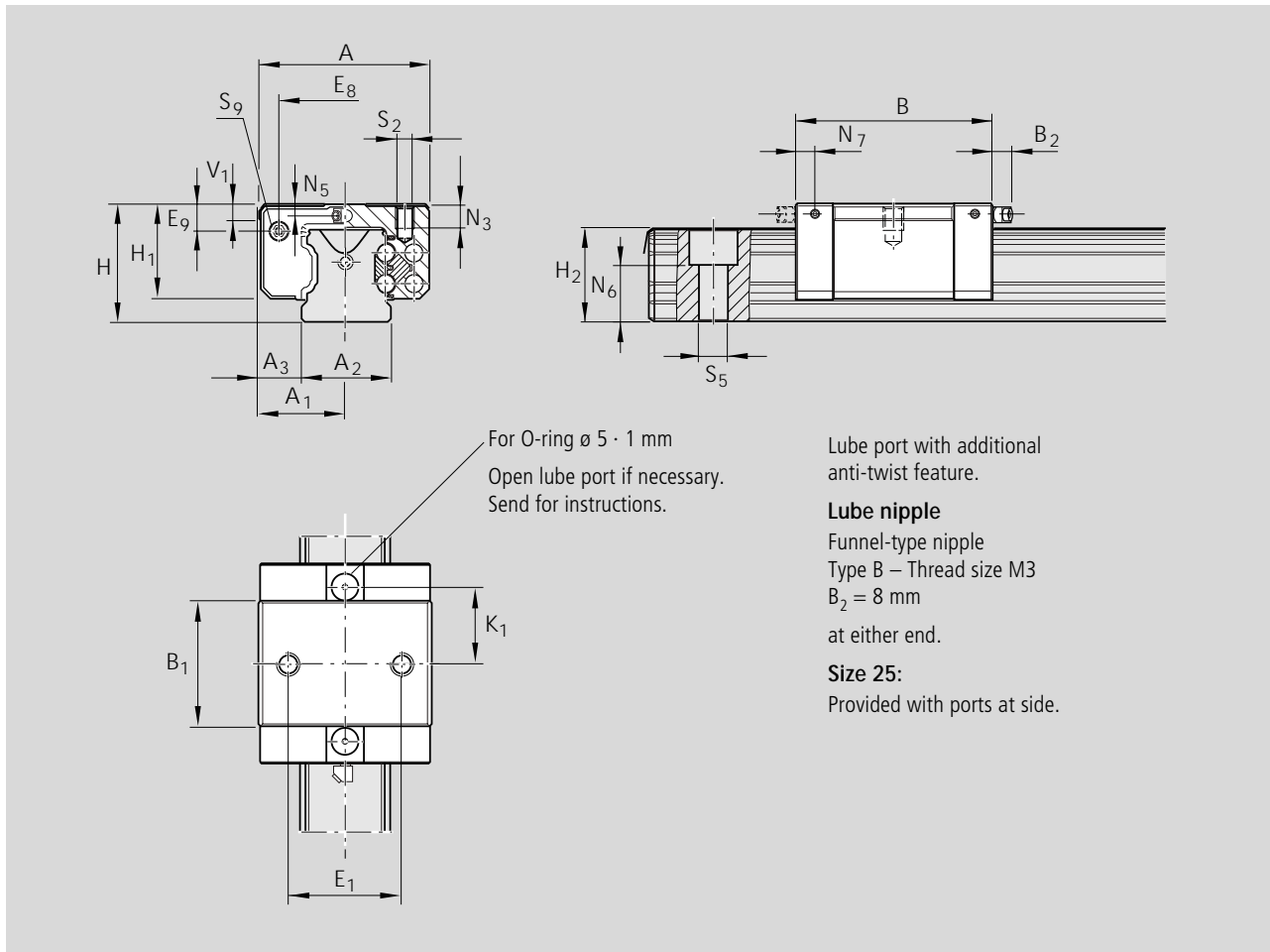



Dimensions (mm)																
Size	A	A ₁	A ₂	A ₃	B	B ₁	H	H ₁	H ₂ ¹⁾	H ₂ ²⁾	V ₁	E ₁	E ₈	E ₉	K ₁	N ₃
20	42	21	20	11.0	55	31.9	28	23.0	20.7	20.55	6.0	32	30.5	5.6	20.1	6.3
25	48	24	23	12.5	62	38.6	33	26.5	24.4	24.25	7.5	35	38.3	8.5	24.5	7.0

¹⁾ Dimension H₂ with Rail Seal® cover strip

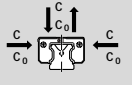
²⁾ Dimension H₂ without Rail Seal® cover strip

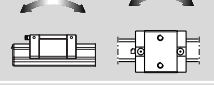
Dimensions (mm)								Load capacities (N)		Moments (Nm)			
Size	N ₅	N ₆ ^{±0.5}	N ₇	S ₂	S ₅	S ₉	Mass (kg)						
								C dyn.	C ₀ stat.	M _t dyn.	M _{t0} stat.	M _L dyn.	M _{L0} stat.
20	3.6	13.2	–	M5	6.0	M3-5 deep	0.30	9 600	13 600	120	170	40	58
25	4.1	15.2	6.0	M6	7.0	M3-5 deep	0.40	15 900*	18 200	235	260	82	94

* 30% higher dynamic load capacity



STAR – Ball Rail® Systems

Runner Blocks, Steel Version

Runner block 1694-

Slimline, low profile

Special versions:

Runner blocks in accuracy class N (clearance and preload 0.02 C) are also available:

- with zinc-iron coating and yellow chromating (part numbers 16...4-30),
- with low friction seals (part numbers 16...4-11).

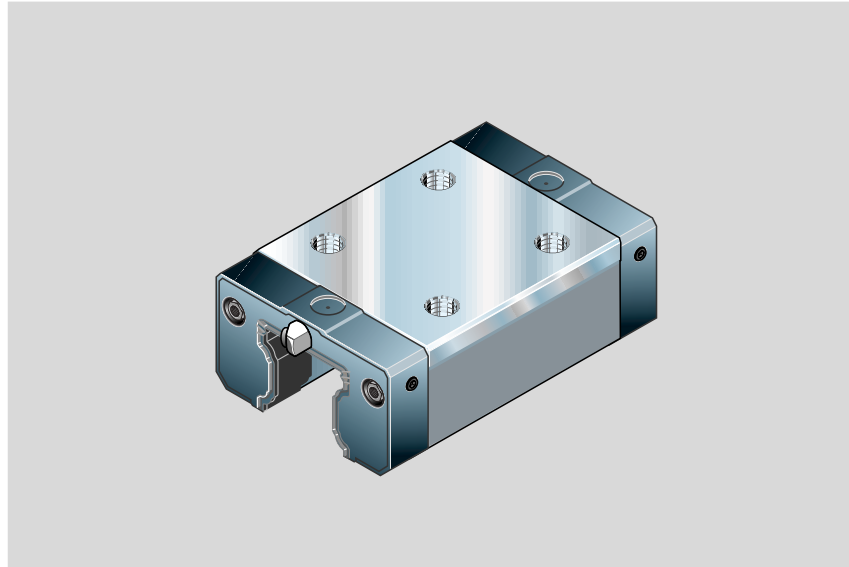

Part numbers

Size	Accuracy class	Part numbers for runner blocks for preload class	
		up to approx. 10 µm clearance	Preload 0.02 C
20	H	1694-893-10	1694-813-10
	N	1694-894-10	1694-814-10
25	H	1694-293-10	1694-213-10
	N	1694-294-10	1694-214-10

Note on dynamic load capacities and moments (see table)

Determination of dynamic load capacities and moments is based on a travel life of 100,000 m.

For comparison with the 50,000 m travel sometimes applied for rail-type guideways, the figures for C , M_t and M_L in the table should be multiplied by 1.26.

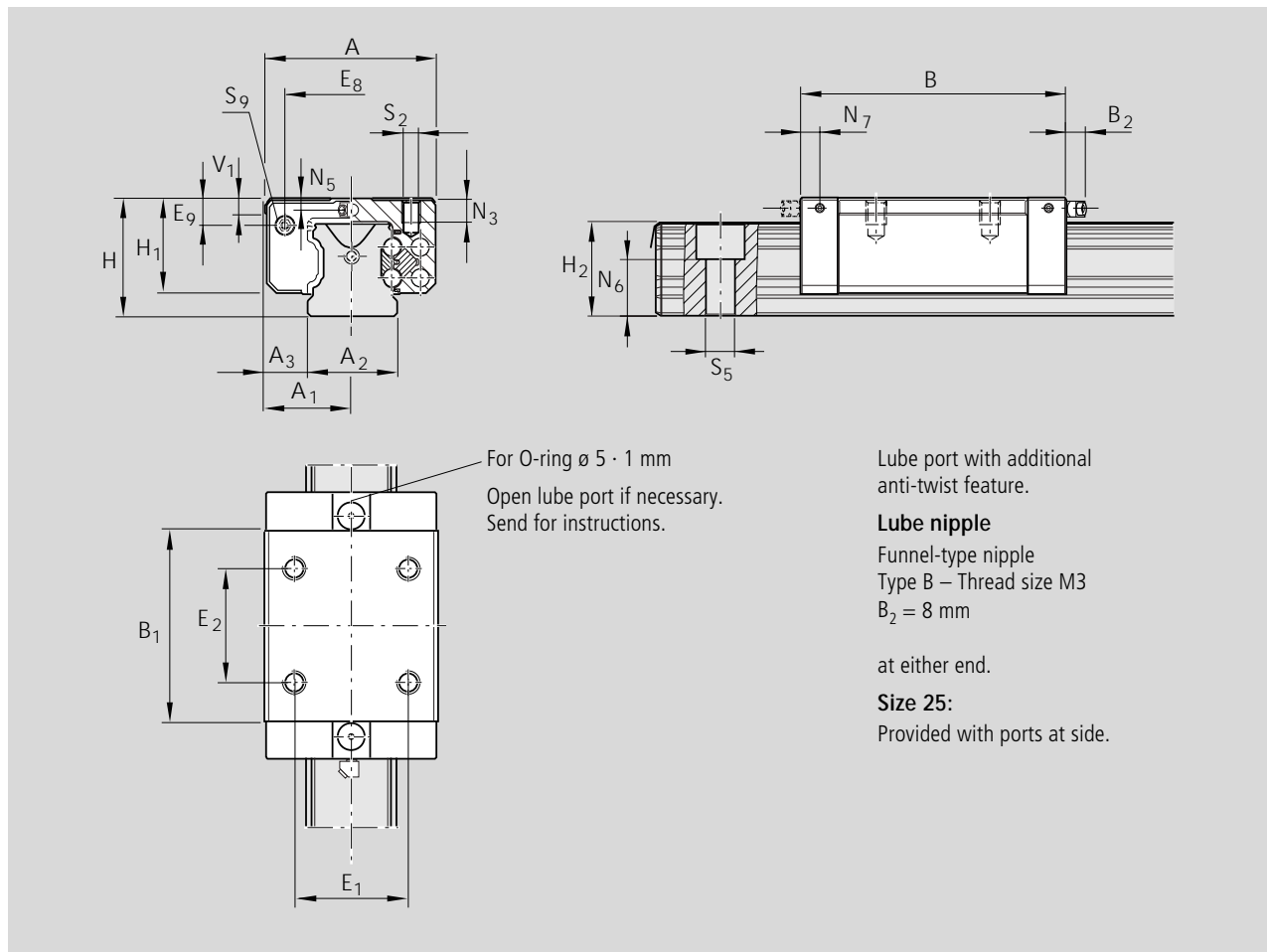

Maße (mm)																	
Größe	A	A ₁	A ₂	A ₃	B	B ₁	H	H ₁	H ₂ ¹⁾	H ₂ ²⁾	V ₁	E ₁	E ₂	E ₈	E ₉	K ₁	N ₃
20	42	21	20	11.0	72.5	49.6	28	23.0	20.7	20.55	6.0	32	32	30.5	5.6	13.0	6.3
25	48	24	23	12.5	81.0	57.8	33	26.5	24.4	24.25	7.5	35	35	38.3	8.5	16.6	7.0

¹⁾ Dimension H₂ with Rail Seal® cover strip

²⁾ Dimension H₂ without Rail Seal® cover strip

Dimensions (mm)								Load capacities (N)		Moments (Nm)			
								C dyn.	C ₀ stat.	M _t dyn.	M _{t0} stat.	M _L dyn.	M _{L0} stat.
Size	N ₅	N ₆ ^{±0.5}	N ₇	S ₂	S ₅	S ₉	Mass (kg)						
20	3.6	13.2	–	M5	6.0	M3-5 deep	0.40	14 500	24 400	190	310	100	165
25	4.1	15.2	6.0	M6	7.0	M3-5 deep	0.55	22 800*	30 400	320	430	180	240

* 30% higher dynamic load capacity

STAR – Ball Rail® Systems

Runner Blocks, Steel Version

Runner block 1621- Slimline, high

Special versions:

Runner blocks in accuracy class N (clearance and preload 0.02 C) are also available:

- with zinc-iron coating and yellow chromating (part numbers 16...4-30),
- with low friction seals (part numbers 16...4-11).

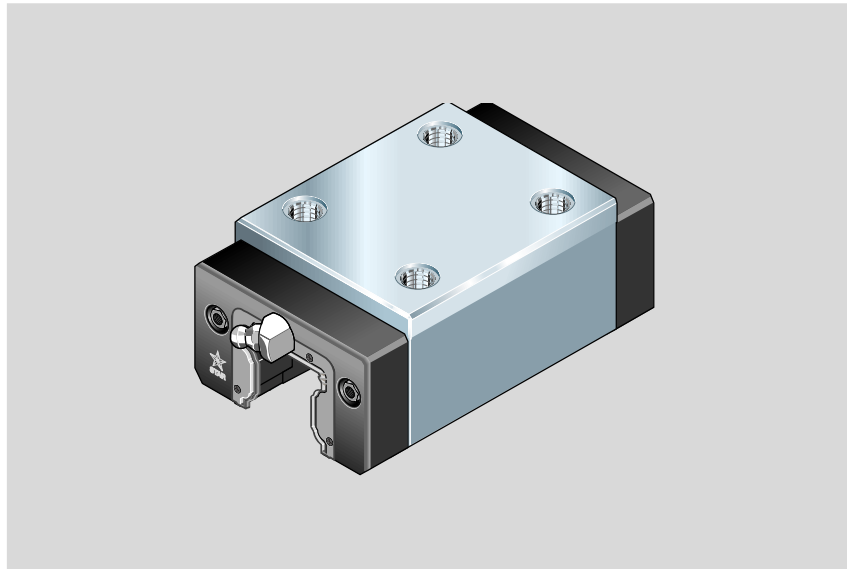

Part numbers

* 30% higher dynamic load capacities on request

Size	Accuracy class	Part numbers for runner blocks for preload class			
		up to approx. 10 µm clearance	Preload 0.02 C	Preload 0.08 C	Preload 0.13 C
15	P		1621-112-10	1621-122-10	1621-132-10
	H	1621-193-10	1621-113-10	1621-123-10	
	N	1621-194-10	1621-114-10	1621-124-10	
25	P		1621-212-10	1621-222-10	1621-232-10
	H	1621-293-10	1621-213-10	1621-223-10	
	N	1621-294-10	1621-214-10	1621-224-10	
30	P		1621-712-10	1621-722-10	1621-732-10
	H	1621-793-10	1621-713-10	1621-723-10	
	N	1621-794-10	1621-714-10	1621-724-10	
35	P		1621-312-10	1621-322-10	1621-332-10
	H	1621-393-10	1621-313-10	1621-323-10	
	N	1621-394-10	1621-314-10	1621-324-10	
45	P		1621-412-10	1621-422-10	1621-432-10
	H	1621-493-10	1621-413-10	1621-423-10	
	N	1621-494-10	1621-414-10	1621-424-10	
55	P		1621-512-10*	1621-522-10*	1621-532-10*
	H	1621-593-10*	1621-513-10*	1621-523-10*	
	N	1621-594-10*	1621-514-10*	1621-524-10*	

Note on dynamic load capacities and moments (see table)

Determination of dynamic load capacities and moments is based on a travel life of 100,000 m.

For comparison with the 50,000 m travel sometimes applied for rail-type guideways, the figures for C , M_t and M_L in the table should be multiplied by 1.26.



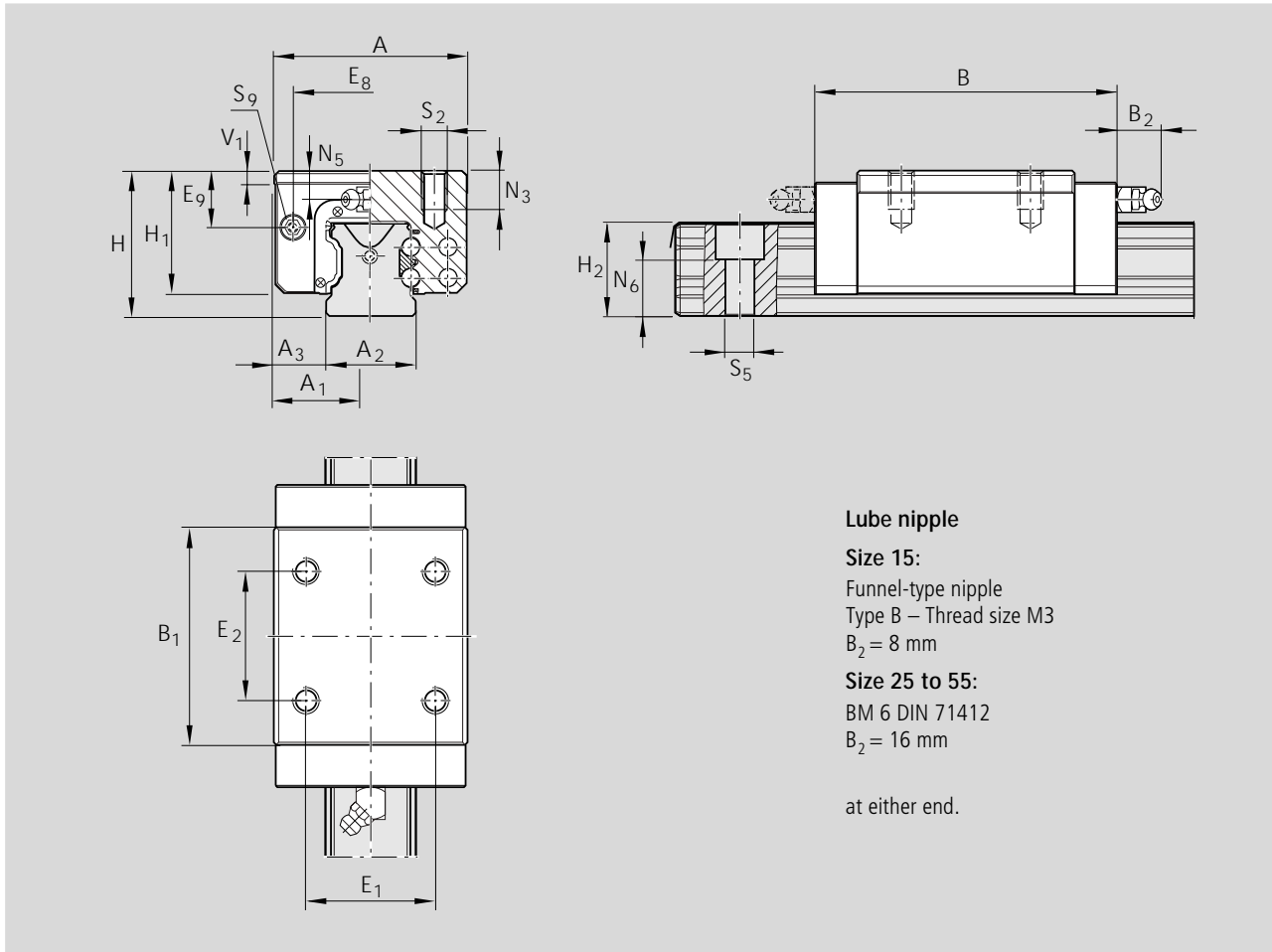

Lube nipple

Size 15:

Funnel-type nipple
 Type B – Thread size M3
 $B_2 = 8 \text{ mm}$

Size 25 to 55:

BM 6 DIN 71412
 $B_2 = 16 \text{ mm}$

at either end.

Size	Dimensions (mm)															
	A	A ₁	A ₂	A ₃	B	B ₁	H	H ₁	H ₂ ¹⁾	H ₂ ²⁾	V ₁	E ₁	E ₂	E ₈	E ₉	N ₃
15	34	17	15	9.5	54.0	39.2	28	23.8	16.3	16.20	5.0	26	26	24.55	10.7	6
25	48	24	23	12.5	81.0	57.8	40	33.5	24.4	24.25	7.5	35	35	38.3	15.5	9
30	60	30	28	16.0	94.0	67.4	45	38.0	28.5	28.35	7.0	40	40	48.4	17.6	12
35	70	35	34	18.0	105.0	77.0	55	47.0	32.15	31.85	8.0	50	50	58.0	24.5	13
45	86	43	45	20.5	133.0	97.0	70	60.0	40.15	39.85	10.0	60	60	70.0	31.0	18
55	100	50	53	23.5	159.0	115.5	80	67.0	48.15	47.85	12.0	75	75	80.0	32.3	19

¹⁾ Dimension H₂ with Rail Seal® cover strip

²⁾ Dimension H₂ without Rail Seal® cover strip

Size	Dimensions (mm)						Mass (kg)	Load capacities (N)		Moments (Nm)			
	N ₅	N ₆ ^{±0.5}	S ₂	S ₅	S ₉	C dyn.		C ₀ stat.	M _t dyn.	M _{t0} stat.	M _L dyn.	M _{L0} stat.	
15	8.0	10.3	M4	4.4	M2.5-3.5 deep	0.20	7 800	13 500	74	130	40	71	
25	9.5	15.2	M6	7.0	M3-5 deep	0.65	22 800	30 400	320	430	180	240	
30	9.0	17.0	M8	9.0	M3-5 deep	1.00	31 700	41 300	540	720	290	380	
35	14.0	20.5	M8	9.0	M3-5 deep	1.50	41 900	54 000	890	1 160	440	565	
45	18.0	23.5	M10	14.0	M4-7 deep	3.00	68 100	85 700	1 830	2 310	890	1 130	
55	19.0	29.0	M12	16.0	M5-8 deep	4.70	98 200	121 400	3 100	3 860	1 540	1 905	

30% higher dynamic load capacities and moments



STAR – Ball Rail® Systems

Runner Blocks, Steel Version

Runner block 1624- Slimline, high, long

Special versions:

Runner blocks in accuracy class N (clearance and preload 0.02 C) are also available:

- with zinc-iron coating and yellow chromating (part numbers 16...4-30),
- with low friction seals (part numbers 16...4-11).

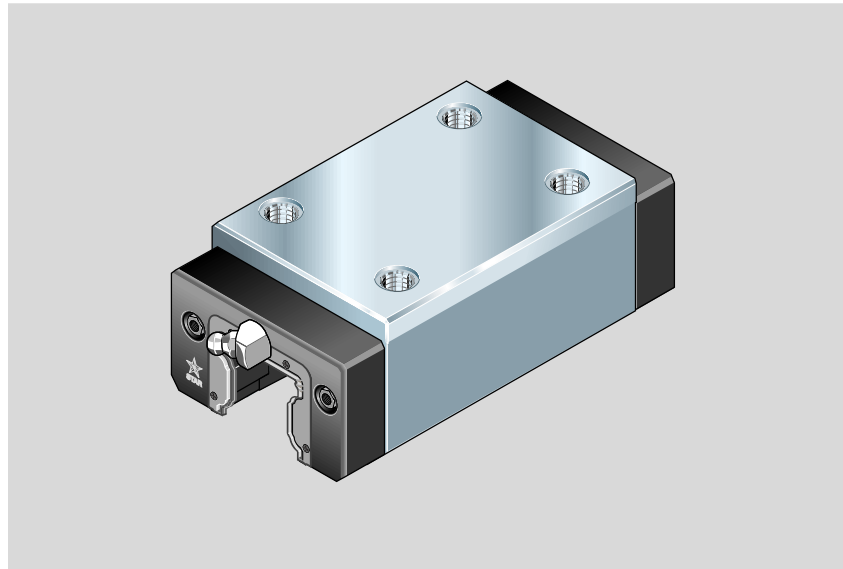

Part numbers

* 30% higher dynamic load capacities on request

Size	Accuracy class	Part numbers for runner blocks for preload class			
		up to approx. 10 µm clearance	Preload 0.02 C	Preload 0.08 C	Preload 0.13 C
25	P		1624-212-10	1624-222-10	1624-232-10
	H	1624-293-10	1624-213-10	1624-223-10	
	N	1624-294-10	1624-214-10	1624-224-10	
30	P		1624-712-10	1624-722-10	1624-732-10
	H	1624-793-10	1624-713-10	1624-723-10	
	N	1624-794-10	1624-714-10	1624-724-10	
35	P		1624-312-10	1624-322-10	1624-332-10
	H	1624-393-10	1624-313-10	1624-323-10	
	N	1624-394-10	1624-314-10	1624-324-10	
45	P		1624-412-10	1624-422-10	1624-432-10
	H	1624-493-10	1624-413-10	1624-423-10	
	N	1624-494-10	1624-414-10	1624-424-10	
55	P		1624-512-10*	1624-522-10*	1624-532-10*
	H	1624-593-10*	1624-513-10*	1624-523-10*	
	N	1624-594-10*	1624-514-10*	1624-524-10*	

Note on dynamic load capacities and moments (see table)

Determination of dynamic load capacities and moments is based on a travel life of 100,000 m.

For comparison with the 50,000 m travel sometimes applied for rail-type guideways, the figures for C , M_t and M_L in the table should be multiplied by 1.26.



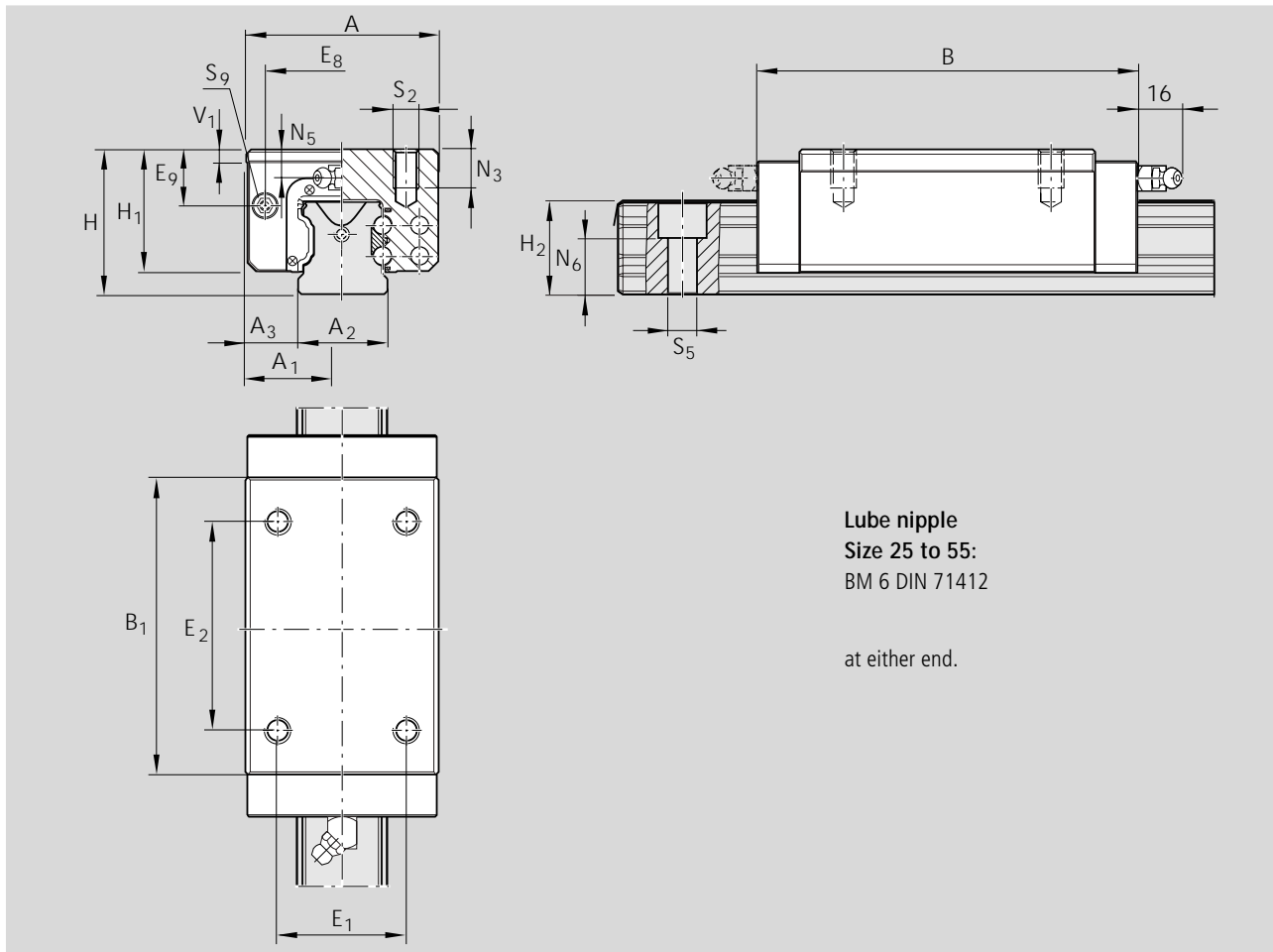

Dimensions (mm)																	
Size	A	A ₁	A ₂	A ₃	B	B ₁	H	H ₁	H ₂ ¹⁾	H ₂ ²⁾	V ₁	E ₁	E ₂	E ₈	E ₉		N ₃
25	48	24	23	12.5	103	79.5	40	33.5	24.4	24.25	7.5	35	50	38.3	15.5		9
30	60	30	28	16.0	116	89.4	45	38.0	28.5	28.35	7.0	40	60	48.4	17.6		12
35	70	35	34	18.0	133	105.5	55	47.0	32.15	31.85	8.0	50	72	58.0	24.5		13
45	86	43	45	20.5	170	133.5	70	60.0	40.15	39.85	10.0	60	80	70.0	31.0		18
55	100	50	53	23.5	200	155.5	80	67.0	48.15	47.85	12.0	75	95	80.0	32.3		19

1) Dimension H₂ with Rail Seal® cover strip

2) Dimension H₂ without Rail Seal® cover strip

Dimensions (mm)							Load capacities (N)		Moments (Nm)			
							C dyn.	C ₀ stat.	M _t dyn.	M _{t0} stat.	M _L dyn.	M _{L0} stat.
Size	N ₅	N ₆ ^{±0.5}	S ₂	S ₅	S ₉	Mass (kg)						
25	9.5	15.2	M6	7.0	M3-5 deep	0.85	30 400	45 500	430	650	345	510
30	9.0	17.0	M8	9.0	M3-5 deep	1.25	40 000	57 800	690	1 000	495	715
35	14.0	20.5	M8	9.0	M3-5 deep	2.10	55 600	81 000	1 200	1 740	830	1 215
45	18.0	23.5	M10	14.0	M4-7 deep	4.00	90 400	128 500	2 440	3 470	1 700	2 425
55	19.0	29.0	M12	16.0	M5-8 deep	6.00	124 200	170 000	3 950	5 400	2 630	3 600

30% higher dynamic load capacities and moments



STAR – Ball Rail® Systems

Product Overview – Runner Blocks, Aluminum Version

STAR Ball Rail® Systems with aluminum runner blocks were specifically developed for use in industrial robots and general purpose machines calling for compact, rolling-element linear motion guideways and are available in different accuracy classes, each with high load capacity and high rigidity.

These compact and weight-saving assemblies are available in 6 common sizes and offer the same high dynamic load capacities in all four main load directions.

Make up your own compact linear motion guideways from interchangeable standard stock elements...

STAR manufactures its guide rails and runner blocks with such high precision, especially in the ball track zone, that each individual component element can be replaced by another at any time. This makes infinite combinations possible within each accuracy class.

Each element can be individually ordered and separately stocked.

Both sides of the guide rail can be used as reference edges.

The runner block is simply pushed onto the rail.

▶ Lube ports possible at either end for added ease of maintenance

▶ Very low weight: 60% lighter than the equivalent steel version

▶ Greater permissible parallelism offset as well as greater permissible vertical and horizontal offset of mounting surfaces

▶ Guide rails in accuracy class N also available with surface protection

▶ End face mounting holes for attachment of bellows or scraper plates

▶ Accuracy classes H and N can be combined with any of the rails in each accuracy class

▶ For mounting from above or below

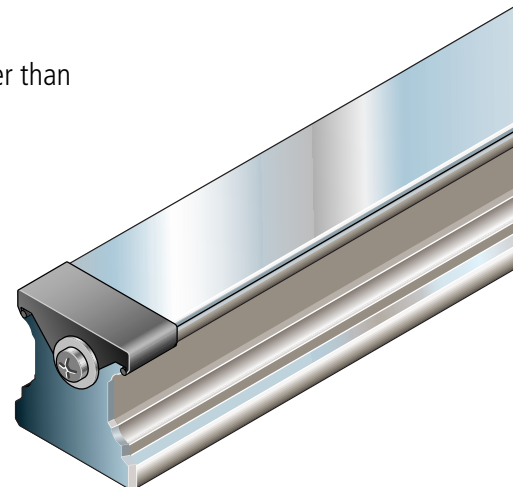

30% higher dynamic load capacities and moments than previous design.

- extends service life by a factor of 2.2
- field-proven
- identical in all four main load directions

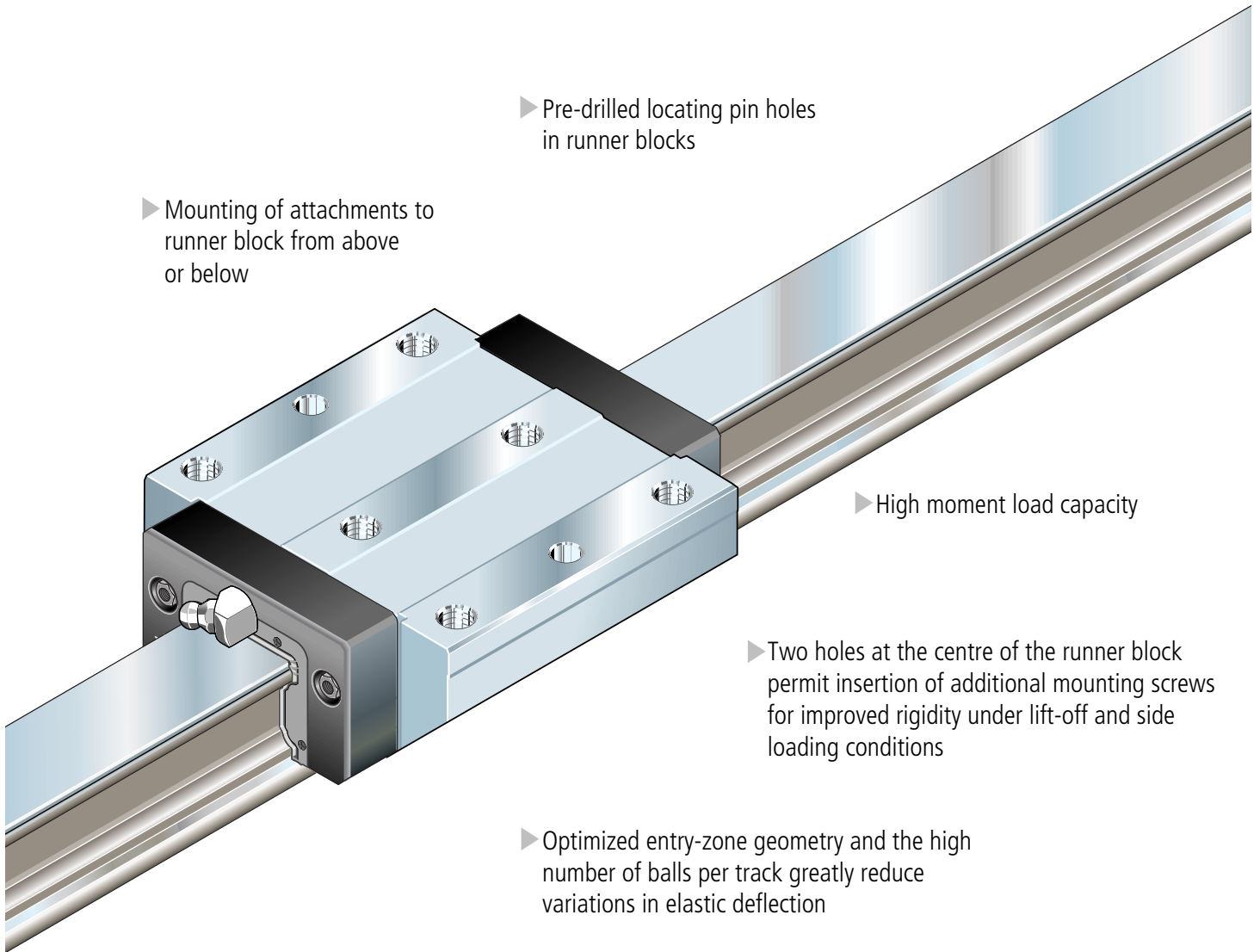

- ▶ Pre-drilled locating pin holes in runner blocks
- ▶ Mounting of attachments to runner block from above or below
- ▶ High moment load capacity
- ▶ Two holes at the centre of the runner block permit insertion of additional mounting screws for improved rigidity under lift-off and side loading conditions
- ▶ Optimized entry-zone geometry and the high number of balls per track greatly reduce variations in elastic deflection
- ▶ Smooth, light running due to optimized ball recirculation and ideal track geometry

Proven Rail Seal® cover strip for guide rail mounting holes:

- ▶ One cover for all holes
- ▶ Material: corrosion resistant spring steel to DIN 17230 / EN 10088
- ▶ Easy clip-on mounting

STAR – Ball Rail® Systems

Product Description – Runner Blocks, Aluminum Version

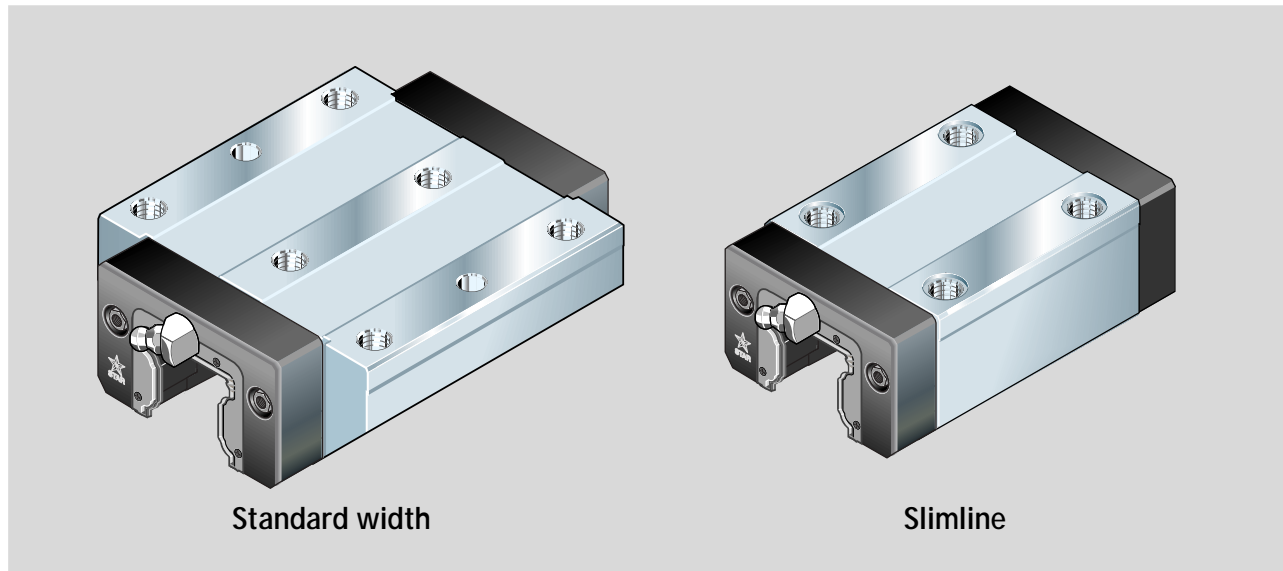

Standard width

Slimline

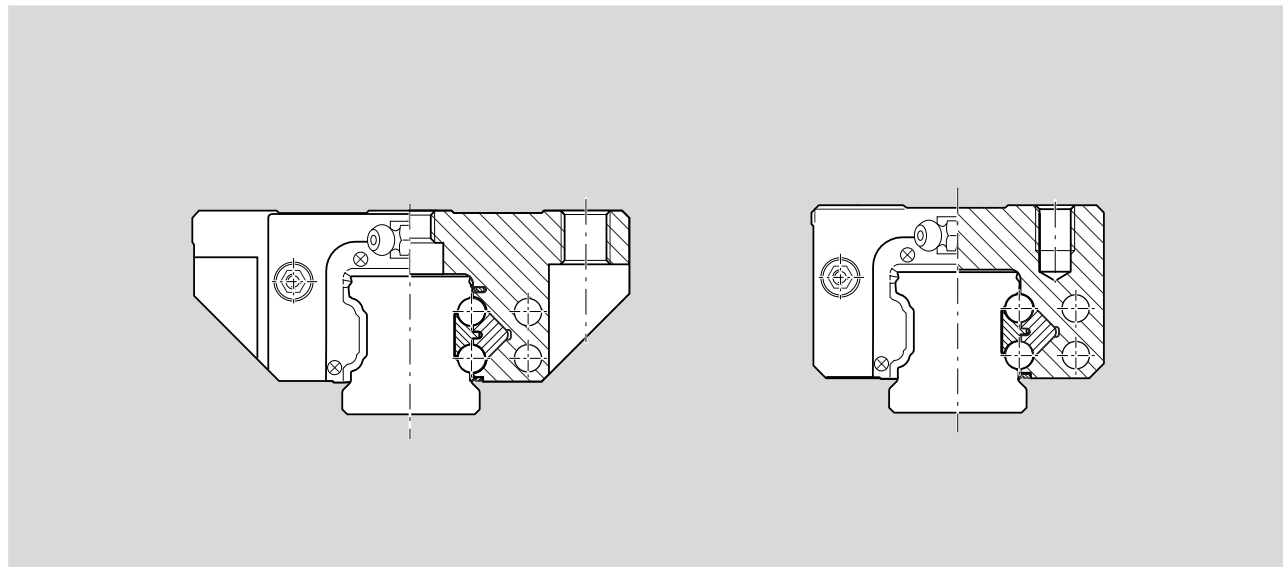

The Ball Rail® System consists of:

- A guide rail with all surfaces ground and ball track zones hardened
- A high-strength aluminum alloy runner block with
 - hardened and ground steel load bearing plates with ball tracks
 - cage designed for optimum ball recirculation
 - integral all-round sealing of all tracks
 - bearing steel balls

Technical Data – Runner Blocks, Aluminum Version

Accuracy classes and their tolerances (µm)

STAR Ball Rail® Systems with runner blocks in aluminum are offered in two different accuracy classes.

However, these can be combined with guide rails of all accuracy classes.

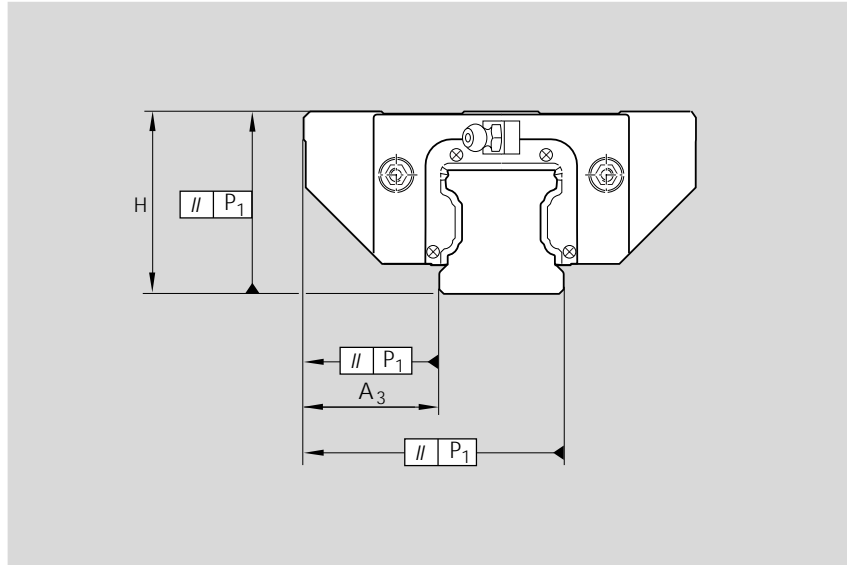

Built-in interchangeability through precision machining

STAR manufactures its guide rails and runner blocks with such high precision, especially in the ball track zone, that each individual component element can be replaced by another at any time.

A runner block can be used without problems on various guide rails of the same size, for example.

This applies equally to the use of different runner blocks on one and the same guide rail.

Accuracy classes	Dimensional tolerances H and A ₃ (µm)		Max difference in dimensions H and A ₃ on the same rail ΔH, ΔA ₃ (µm)
	H	A ₃	
H	± 40	± 20	15
N	± 100	± 40	30

Measured at middle of runner block:		For any runner block/rail combination at any position on rail
		For different runner blocks at same position on rail

Parallelism offset P₁ of the Ball Rail System in service

Measured at middle of runner block

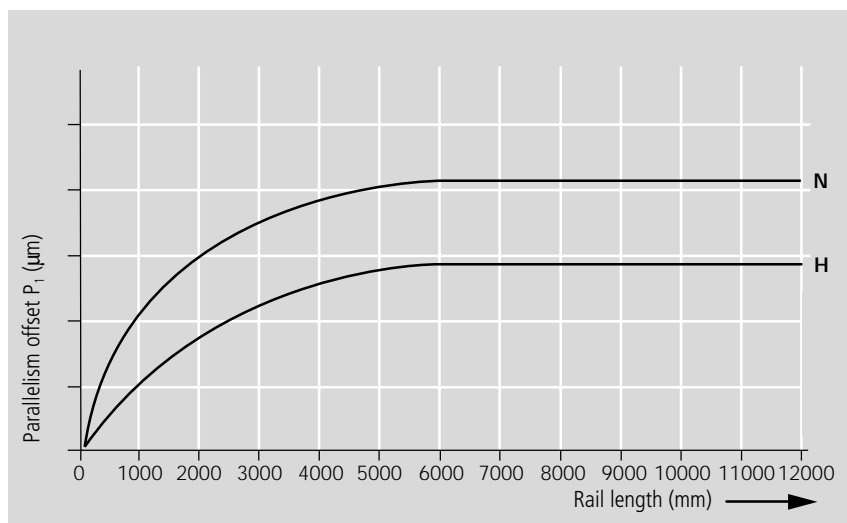

STAR – Ball Rail® Systems

Technical Data – Runner Blocks, Aluminum Version

Rigidity of the Ball Rail® System at 0.02 C preload

Runner block 1631-
Standard width

————— measured values

Runner block mounted with 6
screws, screw strength 8.8

- - - - - measured values

Runner block mounted with 4
screws, screw strength 8.8

1. Down load

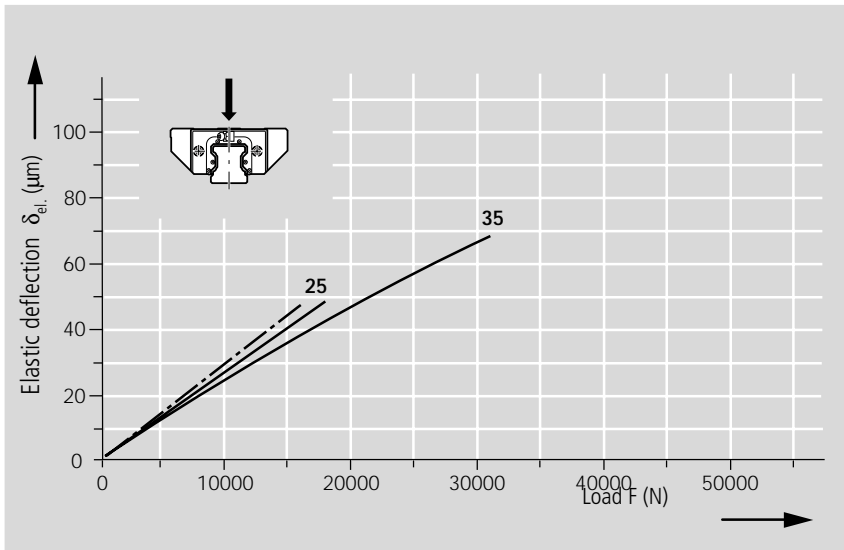

2. Lift-off load

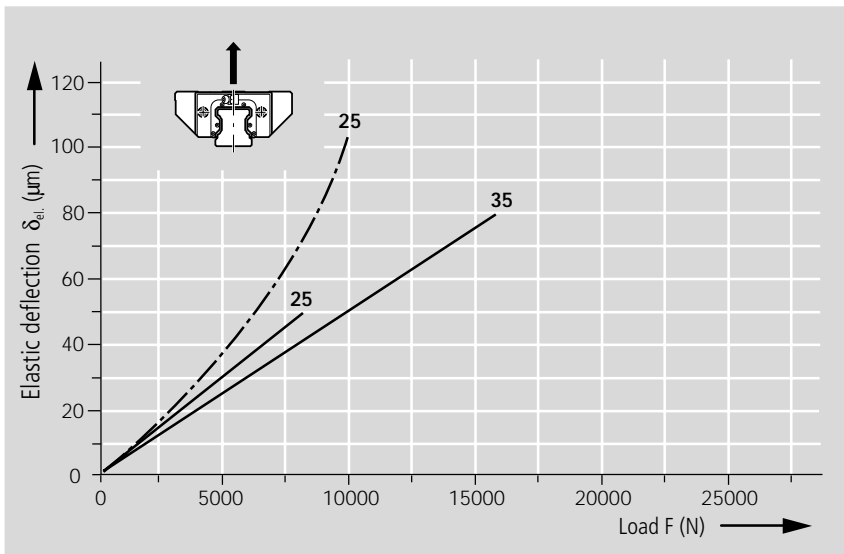

3. Side load

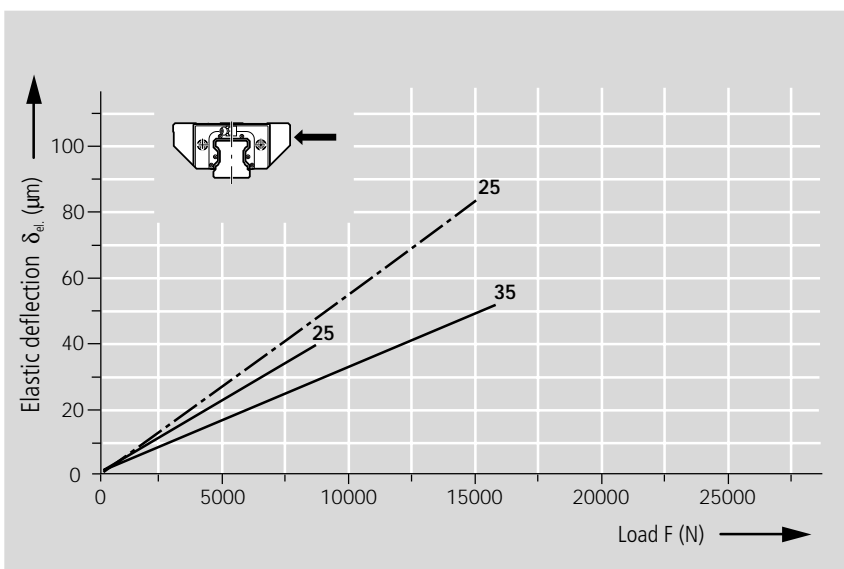

Mounting Instructions – Aluminum Runner Blocks

Reference edges, corner radii, mounting screw sizes and tightening torque

Runner block 1631-

– Standard width

Guide rails

left:

– For mounting from above 1605, 1645-

right:

– For mounting from below 1607, 1647-

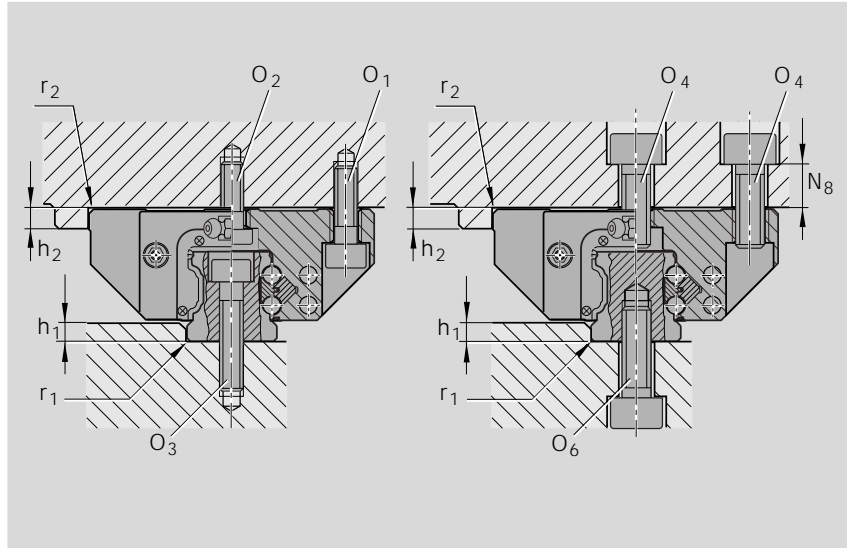

Runner block 1632-

– Slimline

Guide rails

– For mounting from above 1605-, 1645-

Note

The indicated combinations represent examples. It is on principle possible to combine any runner block with all the offered guide rail types.

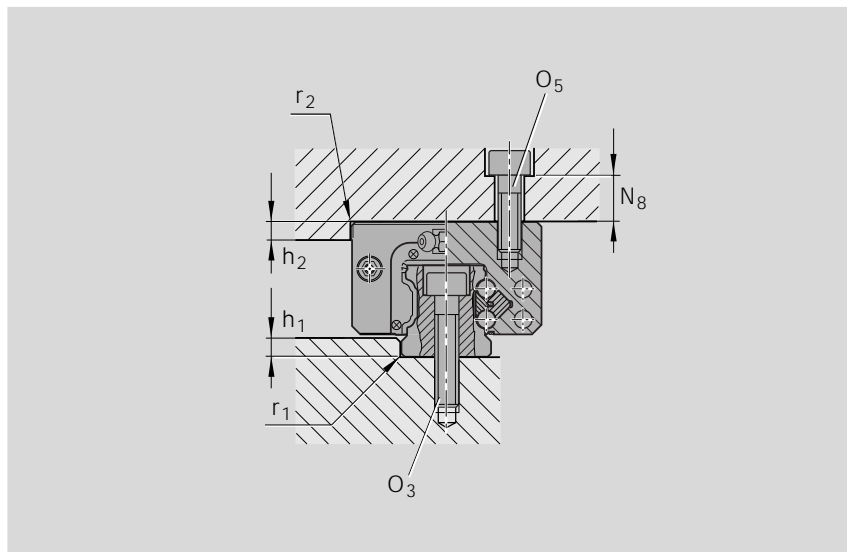

Dimensions and recommended limits for side load if no additional lateral retention is provided

Size	h ₁		r ₁	h ₂	r ₂	O ₁	O ₂	O ₄	O ₅	O ₃	O ₆	N ₈
	min. (mm)	max. (mm)	max. (mm)	(mm)	max. (mm)	DIN 912 4 pcs.	DIN 6912 2 pcs.	DIN 912 6 pcs.	DIN 912 4 pcs.	DIN 912	DIN 912	(mm)
15	2.5	3.5	0.4	4	0.6	M4x12	M4x10	M5x12	M4x12	M4x20	M5x12	6
25	3.0	5.0	0.8	5	0.8	M6x20	M6x16	M8x20	M6x18	M6x30	M6x20	10
30	3.0	5.0	0.8	6	0.8	M8x25	M8x16	M10x20	M8x20	M8x30	M8x20	10
35	3.5	6.0	0.8	6	0.8	M8x25	M8x20	M10x25	M8x25	M8x35	M8x25	13

Screw strength class	Runner blocks				Guide rails	
	8.8	0.11 C	0.15 C ¹⁾	0.23 C	0.11C	0.06 C

¹⁾ When mounting with 4 O₁ screws and 2 O₂ screws

Tightening torque of the mounting screws

Nm	Screw sizes							
	M4	M5	M6	M8	M10	M12	M14	M16
8.8	2.7	5.5	9.5	23	46	80	125	195

STAR – Ball Rail® Systems

Mounting Instructions – Aluminum Runner Blocks

Locating pins

If the recommended values for permissible side forces are exceeded, the runner block must be additionally fixed by means of locating pins or reference edges.

Possible pin types

- Taper pin (hardened) or
- Straight pin DIN 6325

Note

Runner block Standard width 1631-:
Pin holes already drilled as illustrated

Runner block Slimline 1632-:

Recommended dimensions for the pin holes are indicated in the drawings and table.

For both types of runner blocks:

If the locating pins have to be driven in at another point (e.g. when the lube port is central), dimension E_2 must not be exceeded in the longitudinal direction (for dimension E_2 , see the tables for the individual types).

Observe dimensions E_1 and E_4 !

Only prepare the pin holes after the installation is complete (see also "General Mounting Instructions").

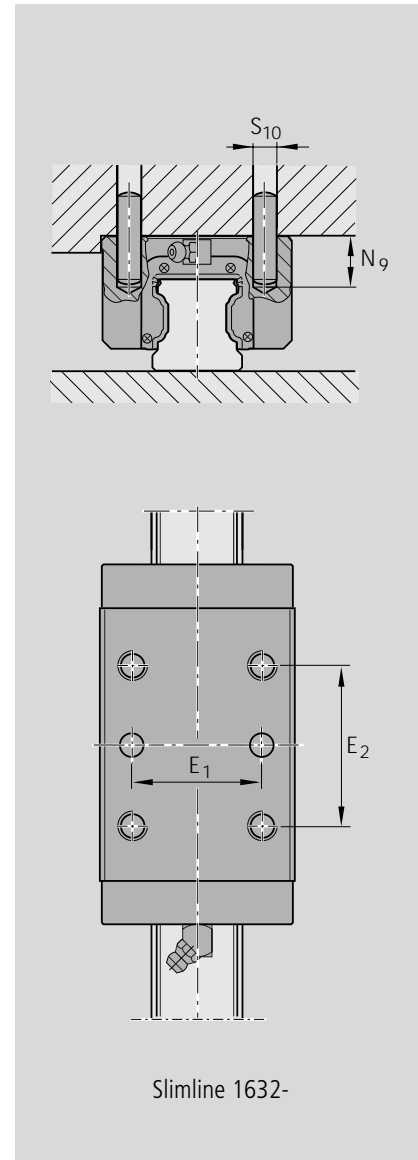
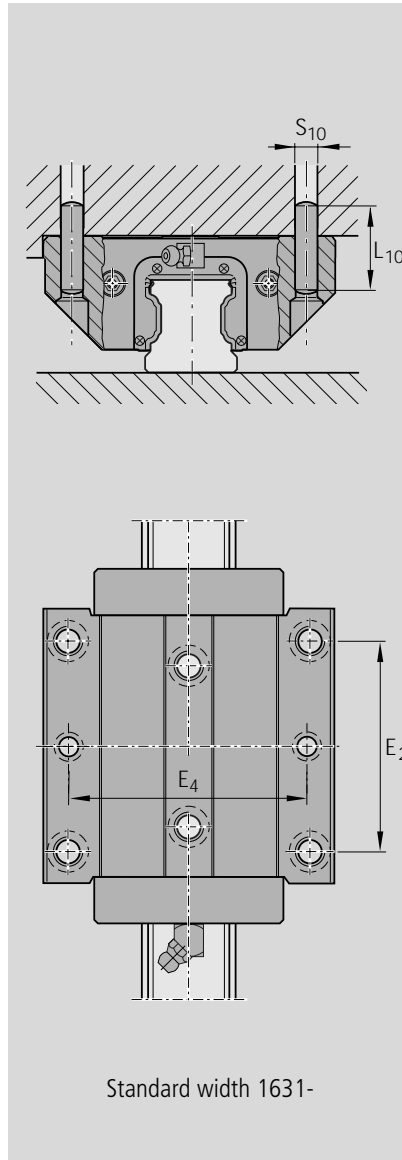

Size	Taper pin (hardened) Straight pin (DIN 6325)		Dimensions (mm)		
	S_{10}	L_{10}	E_1	E_4	N_9 (max)
15	4	18	26	38	6.0
25	6	32	35	55	9.0
30	8	36	40	70	12.0
35	8	40	50	80	13.0

Parallelism of the rails after mounting

measured at the guide rails and at the runner blocks

The parallelism offset P_1 causes a slight increase in preload on one side of the assembly. If the tolerances given in the table are not exceeded, reduction in travel life will as a rule be negligible.

The given values apply to precision mounting. For standard mounting, double the stated values can be used.

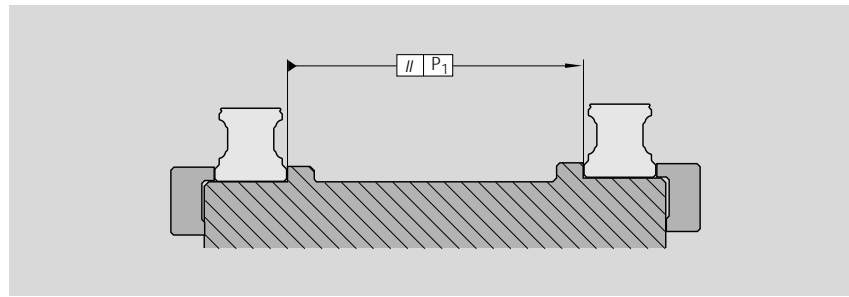

Size	Parallelism offset P_1 (mm)	
	up to approx. 10 μm clearance	Preload 0.02 C
15	0.021	0.014
25	0.026	0.017
30	0.029	0.019
35	0.035	0.022

Vertical offset

Provided the permissible vertical offset S_1 and S_2 is not exceeded, any resultant reduction in travel life will as a rule be negligible.

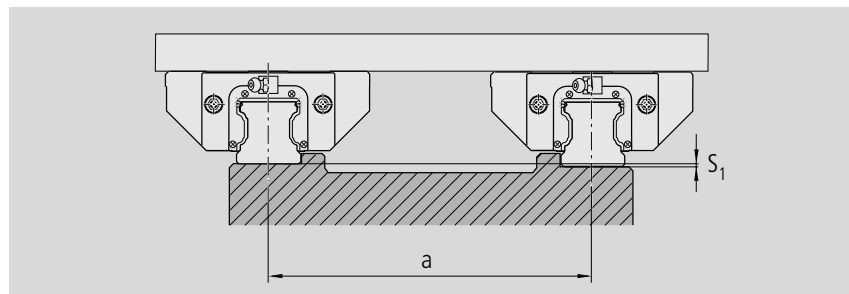

Permissible vertical offset in the transverse direction

The permissible vertical offset S_1 includes the tolerance for dimension H in accordance with the table given in the "Technical Data" section.

$S_1 = a \cdot Y$	S_1 = Permissible vertical offset (mm) a = Distance between rails (mm) Y = Calculation factor
-------------------	---

Calculation factor	for preload class	
	up to approx. 10 μm clearance	Preload 0.02 C
Y	$7 \cdot 10^{-4}$	$5 \cdot 10^{-4}$

Permissible vertical offset in the longitudinal direction

The permissible vertical offset S_2 takes into account the tolerance for the "max. difference in dimensions H on the same rail" according to the table given in the "Technical Data" section.

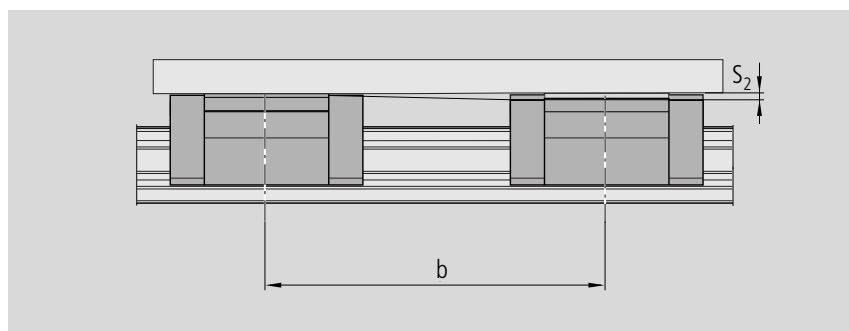

$S_2 = b \cdot 6 \cdot 10^{-5}$	S_2 = Permissible vertical offset (mm) b = Distance between runner blocks (mm)
---------------------------------	---



STAR – Ball Rail® Systems

Runner Blocks, Aluminum Version

Runner block 1631- Standard width

Special versions:

Runner blocks in accuracy class N (clearance and preload 0.02 C) are available:

- with low-friction seals (Part numbers 16...4-11).

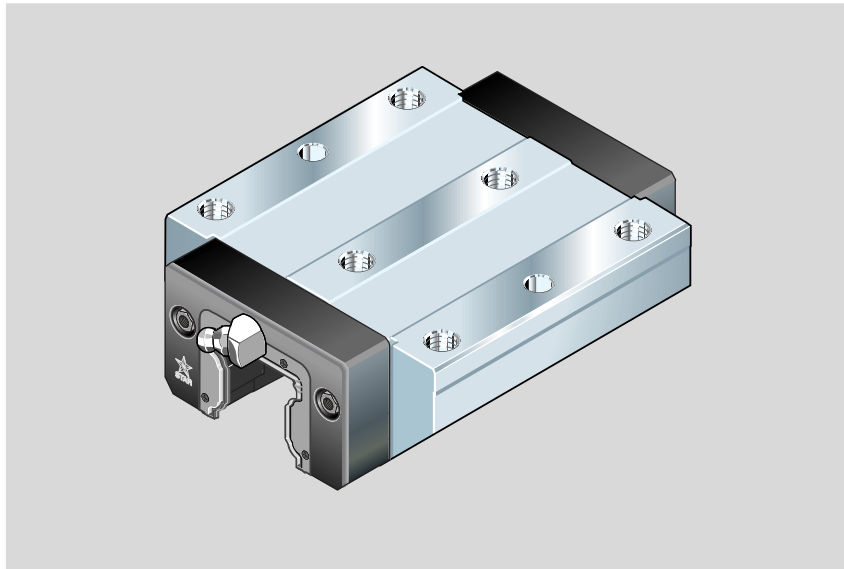

Part numbers

Sizes 45 and 55 available as special versions.

Size	Accuracy class	Part numbers for runner blocks for preload class	
		up to approx. 10 µm clearance	Preload 0.02 C
15	H	1631-193-10	1631-113-10
	N	1631-194-10	1631-114-10
25	H	1631-293-10	1631-213-10
	N	1631-294-10	1631-214-10
30	H	1631-793-10	1631-713-10
	N	1631-794-10	1631-714-10
35	H	1631-393-10	1631-313-10
	N	1631-394-10	1631-314-10

Permissible load

When calculating the service life, use the maximum load capacity figure.

The permissible load is only limited for statistical purposes (see table).

Note on dynamic load capacities and moments (see table)

Determination of dynamic load capacities and moments is based on a travel life of 100,000 m.

For comparison with the 50,000 m travel sometimes applied for rail-type guideways, the figures for C , M_t and M_l in the table should be multiplied by 1.26.



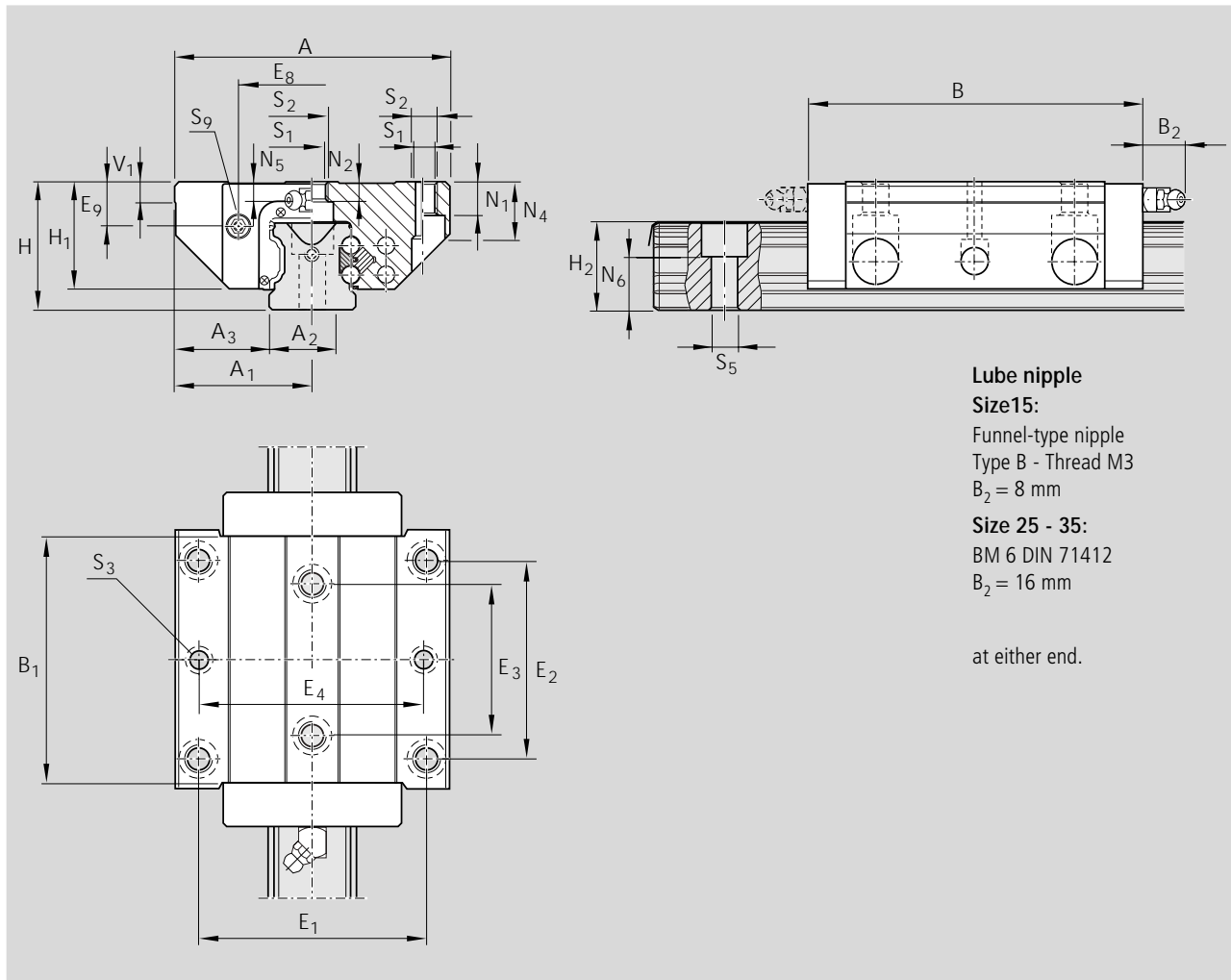

Lube nipple

Size15:

Funnel-type nipple
Type B - Thread M3
B₂ = 8 mm

Size 25 - 35:

BM 6 DIN 71412
B₂ = 16 mm

at either end.

Size	Dimensions (mm)																			
	A	A ₁	A ₂	A ₃	B	B ₁	H	H ₁	H ₂ ¹⁾	H ₂ ²⁾	V ₁	E ₁	E ₂	E ₃	E ₄	E ₈	E ₉	N ₁	N ₂	N ₄
15	47	23.5	15	16.0	54	39.2	24	19.8	16.3	16.20	5.0	38	30	26	38	24.55	6.7	5	4.4	10
25	70	35.0	23	23.5	81.0	57.8	36	29.5	24.4	24.25	7.5	57	45	40	55	38.3	11.5	9	7.0	18
30	90	45.0	28	31.0	94.0	67.4	42	35.0	28.5	28.35	7.0	72	52	44	70	48.4	14.6	11	8.0	18
35	100	50.0	34	33.0	105.0	77.0	48	40.0	32.15	31.85	8.0	82	62	52	80	58.0	17.5	12	10.2	21

1) Dimension H₂ with Rail Seal® cover strip

2) Dimension H₂ without Rail Seal® cover strip

Size	Dimensions (mm)								Mass (kg)	Load capacities (N) C dyn.	Permissible load (N) F _{max}	Moments (Nm)			
	N ₅	N ₆ ^{±0.5}	S ₁	S ₂	S ₃	S ₅	S ₉	M _t				M _L			
								dyn.				max.	dyn.	max.	
15	4.0	10.3	4.4	M5	3.7	4.4	M2.5-3.5 deep	0.15	7 800	3 000	74	29	40	16	
25	5.5	15.2	6.8	M8	5.7	7.0	M3-5 deep	0.35	22 800	8 800	320	125	180	70	
30	6.0	17.0	8.6	M10	7.7	9.0	M3-5 deep	0.45	31 700	12 200	540	210	290	110	
35	7.0	20.5	8.6	M10	7.7	9.0	M3-5 deep	0.80	41 900	16 200	890	345	440	170	

30% higher dynamic load capacities and moments



STAR – Ball Rail® Systems

Runner Blocks, Aluminum Version

Runner block 1632- Slimline

Special versions:

Runner blocks in accuracy class N (clearance and preload 0.02 C) are available:

- with low-friction seals (Part numbers 16...4-11).

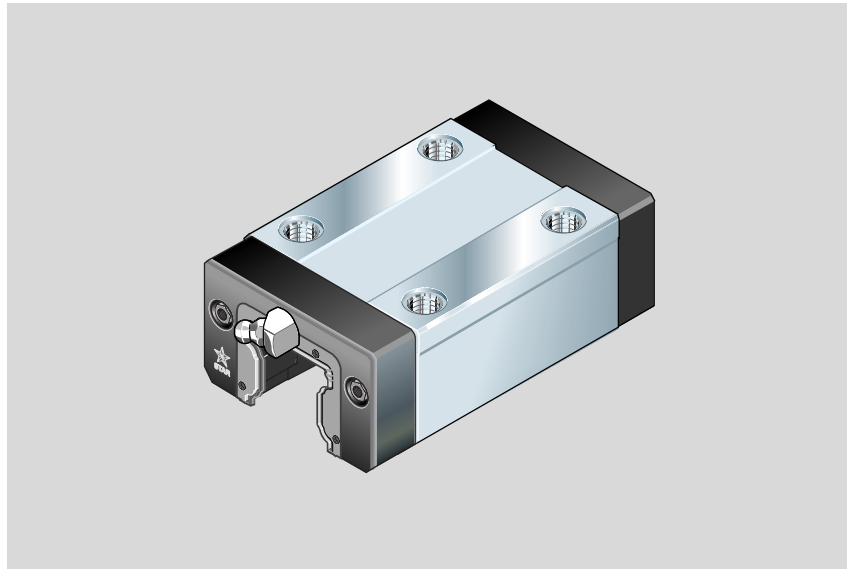

Part numbers

Sizes 45 and 55 available as special versions.

Size	Accuracy class	Part numbers for runner blocks for preload class	
		up to approx. 10 µm clearance	Preload 0.02 C
15	H	1632-193-10	1632-113-10
	N	1632-194-10	1632-114-10
25	H	1632-293-10	1632-213-10
	N	1632-294-10	1632-214-10
30	H	1632-793-10	1632-713-10
	N	1632-794-10	1632-714-10
35	H	1632-393-10	1632-313-10
	N	1632-394-10	1632-314-10

Permissible load

When calculating the service life, use the maximum load capacity figure.

The permissible load is only limited for statistical purposes (see table).

Note on dynamic load capacities and moments (see table)

Determination of dynamic load capacities and moments is based on a travel life of 100,000 m.

For comparison with the 50,000 m travel sometimes applied for rail-type guideways, the figures for C , M_t and M_l in the table should be multiplied by 1.26.



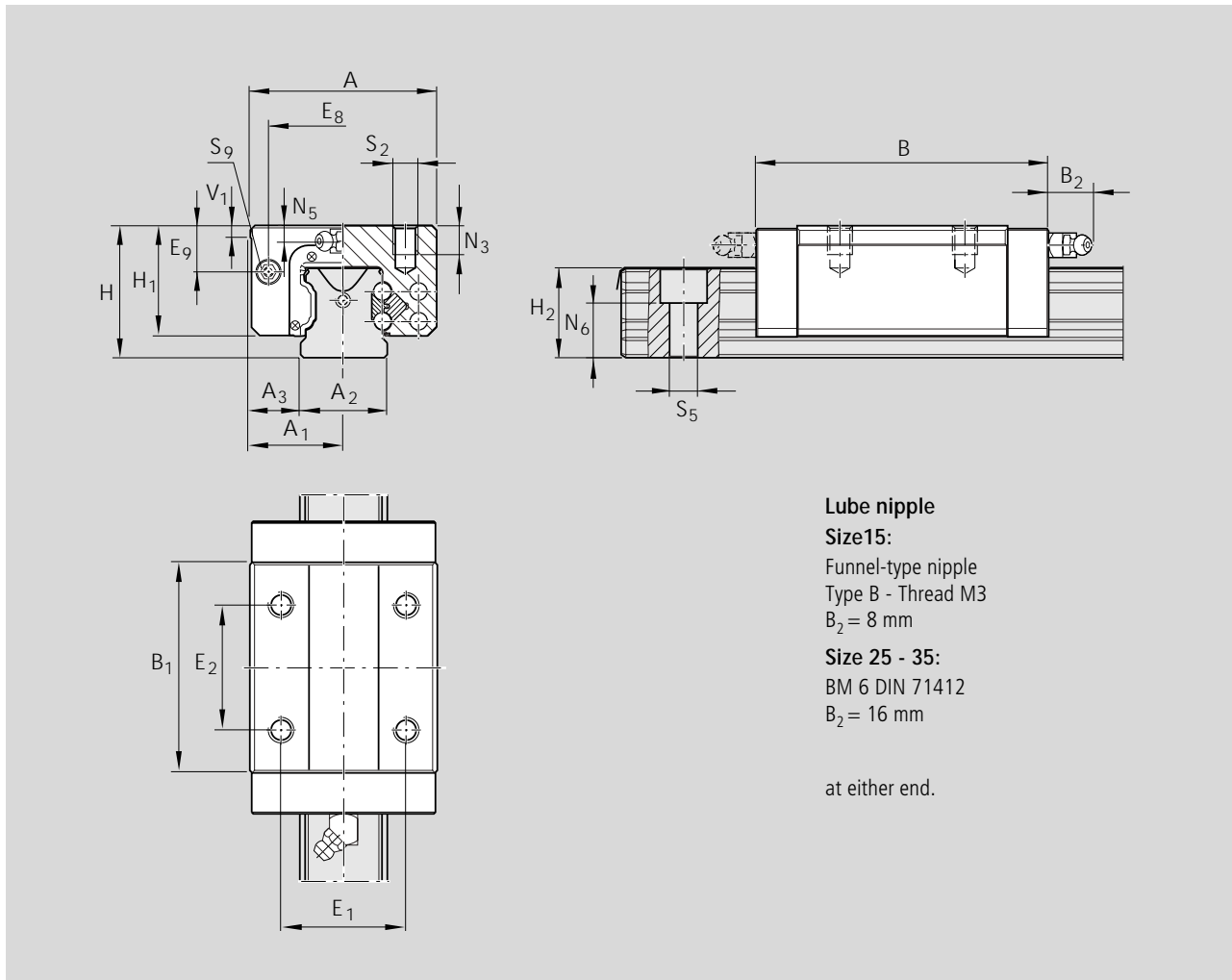

Lube nipple

Size15:

Funnel-type nipple
Type B - Thread M3
B₂ = 8 mm

Size 25 - 35:

BM 6 DIN 71412
B₂ = 16 mm

at either end.

Dimensions (mm)																	
Size	A	A ₁	A ₂	A ₃	B	B ₁	H	H ₁	H ₂ ¹⁾	H ₂ ²⁾	V ₁	E ₁	E ₂	E ₈	E ₉		N ₃
15	34	17	15	9.5	53.5	39.2	24	19.8	16.3	16.20	5.0	26	26	-	-		6
25	48	24	23	12.5	81.0	57.8	36	29.5	24.4	24.25	7.5	35	35	38.3	11.5		9
30	60	30	28	16.0	94.0	67.4	42	35.0	28.5	28.35	7.0	40	40	48.4	14.6		12
35	70	35	34	18.0	105.0	77.0	48	40.0	32.15	31.85	8.0	50	50	58.0	17.5		13

1) Dimension H₂ with Rail Seal® cover strip

2) Dimension H₂ without Rail Seal® cover strip

Size	Dimensions (mm)						Mass (kg)	Load capacities (N) C dyn.	Permissible load (N) F _{max}	Moments (Nm)			
	N ₅	N ₆ ^{±0.5}	S ₂	S ₅	S ₉	M _t dyn.				M _t max.	M _L dyn.	M _L max.	
15	4.0	10.3	M4	4.4	M25-3.5deep	0.08	7 800	3 000	74	29	40	16	
25	5.5	15.2	M6	7.0	M3-5 deep	0.25	22 800	8 800	320	125	180	70	
30	6.0	17.0	M8	9.0	M3-5 deep	0.45	31 700	12 200	540	290	290	110	
35	7.0	20.5	M8	9.0	M3-5 deep	0.60	41 900	16 200	890	440	440	170	

30% higher dynamic load capacities and moments



STAR – Ball Rail® Systems

Technical Data – Wide Ball Rail® Systems

Rigidity of the wide Ball Rail® System at 0.02 C preload

Runner block 1671- Wide

————— measured values

Runner block mounted with six screws:

- 4 outer screws of strength class 12.9
- 2 centerline screws of strength class 8.8

1. Down load

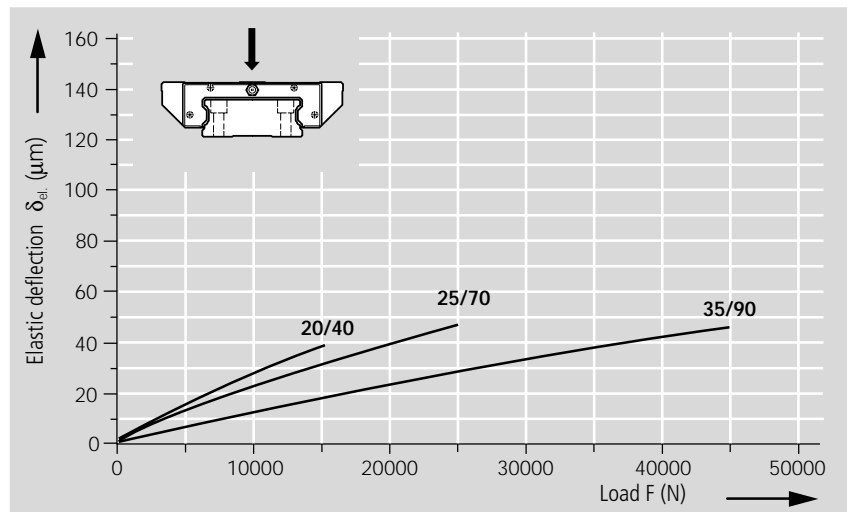

2. Lift-off load

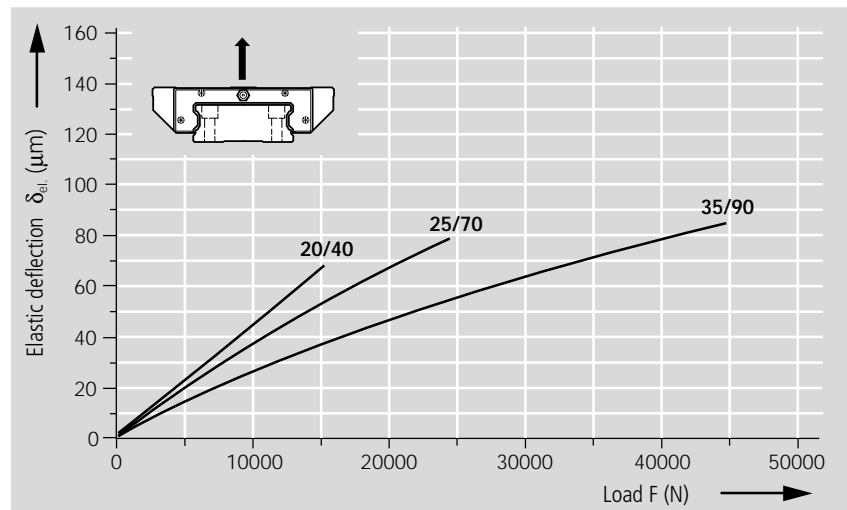

3. Side load

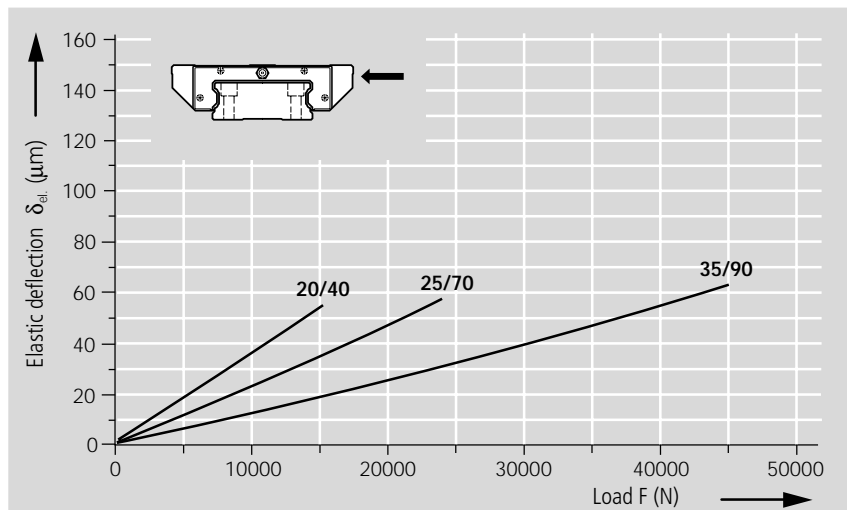

Mounting Instructions

Reference edges, corner radii, mounting screw sizes and tightening torque

Runner block 1671-

- Wide

Guide rail:

- Wide, for mounting from above 1675-

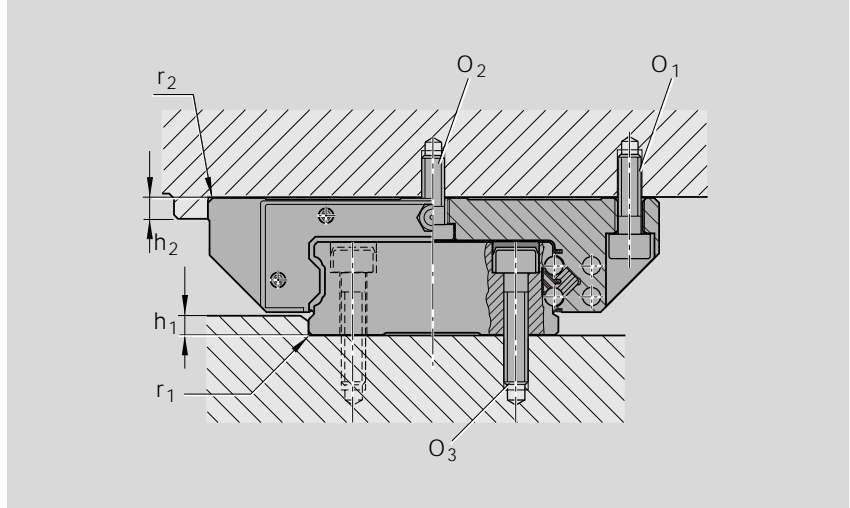

Runner block 1671-

- Wide

Guide rail:

- Wide, for mounting from below 1677-

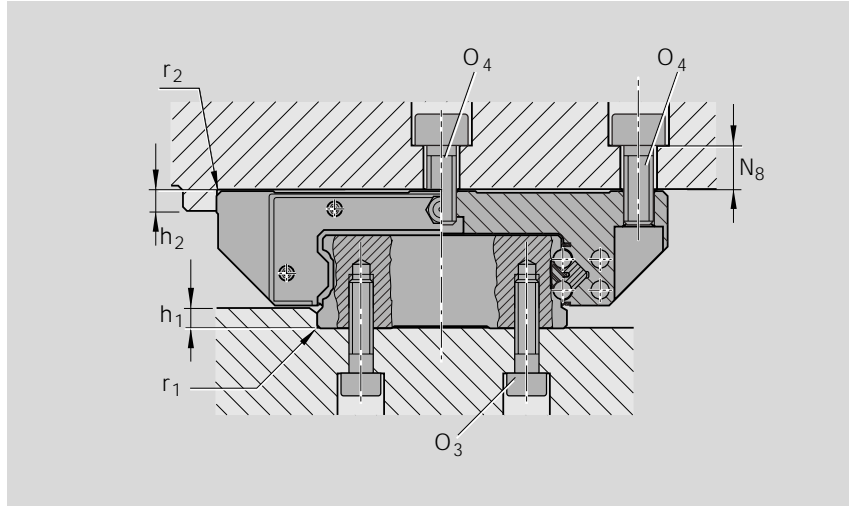

Dimensions and recommended limits for side load if no additional lateral retention is provided

- When mounting the runner block from above using only 4 O₄ screws:
 - Permissible side force 1/3 lower
 - Lower stiffness

- For runner block mounting with 6 screws:
 - Tighten the centerline screws with the torque for strength class 8.8.

- When mounting with 2 O₂ screws and 4 O₁ screws

Size	h ₁		r ₁	h ₂		r ₂	O ₁ DIN 912 4 pcs.	O ₂ ²⁾ DIN 6912 2 pcs.	O ₄ ¹⁾²⁾ DIN 912 6 pcs.	O ₃ DIN 912	N ₈ (mm)
	min.	max.		min.	max.						
20/40	2.0	3.0	0.5	4	0.5		M5x16	M5x12	M6x16	M4x20	9.5
25/70	3.0	4.5	0.8	5	0.8		M6x20	M6x16	M8x20	M6x30	10.0
35/90	3.5	6.0	0.8	6	0.8		M8x25	M8x20	M10x25	M8x35	13.0

Screw strength class	Runner block			Rails
	0.08 C	0.11 ³⁾ C	0.16 C	
	0.13 C	0.16 ³⁾ C	0.24 C	
8.8	0.08 C	0.11 ³⁾ C	0.16 C	0.08 C
12.9	0.13 C	0.16 ³⁾ C	0.24 C	0.13 C

Tightening torque of the mounting screws

Nm	Screw size				
	M4	M5	M6	M8	M10
8.8	2.7	5.5	9.5	23	46
12.9	4.6	9.5	16	39	77

STAR – Ball Rail® Systems

Wide Ball Rail® Systems

Runner blocks
steel version 1671-

Wide

Special versions:

Runner blocks in accuracy class N (clearance and preload 0.02 C) are also available:

- with zinc-iron coating and yellow chromating (Part numbers 16...4-30).

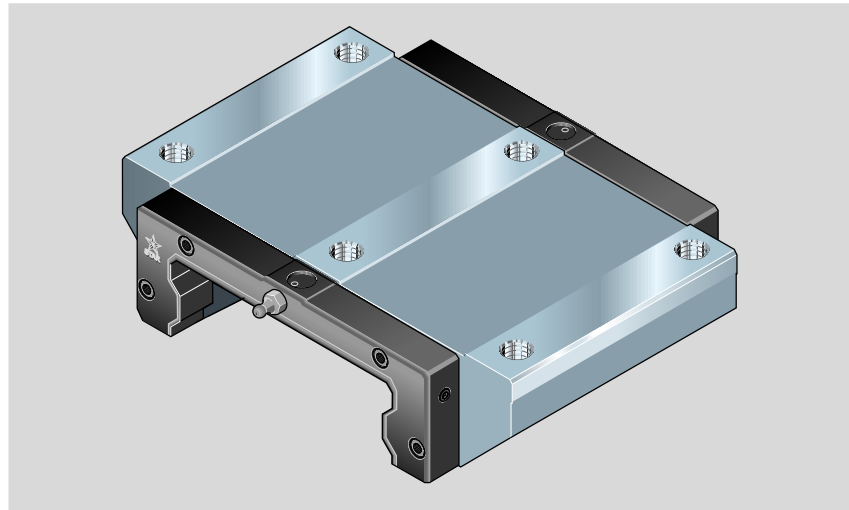

Part numbers

Size	Accuracy class	Part numbers for runner blocks for preload class	
		up to approx. 10 µm clearance	Preload 0.02 C
20/40	P		1671-812-10
	H	1671-893-10	1671-813-10
	N	1671-894-10	1671-814-10
25/70	P		1671-212-10
	H	1671-293-10	1671-213-10
	N	1671-294-10	1671-214-10
35/90	P		1671-312-10
	H	1671-393-10	1671-313-10
	N	1671-394-10	1671-314-10

Note on dynamic load capacities and moments (see table)

Determination of dynamic load capacities and moments is based on a travel life of 100,000 m.

For comparison with the 50,000 m travel sometimes applied for rail-type guideways, the figures for C , M_t and M_L in the table should be multiplied by 1.26 .

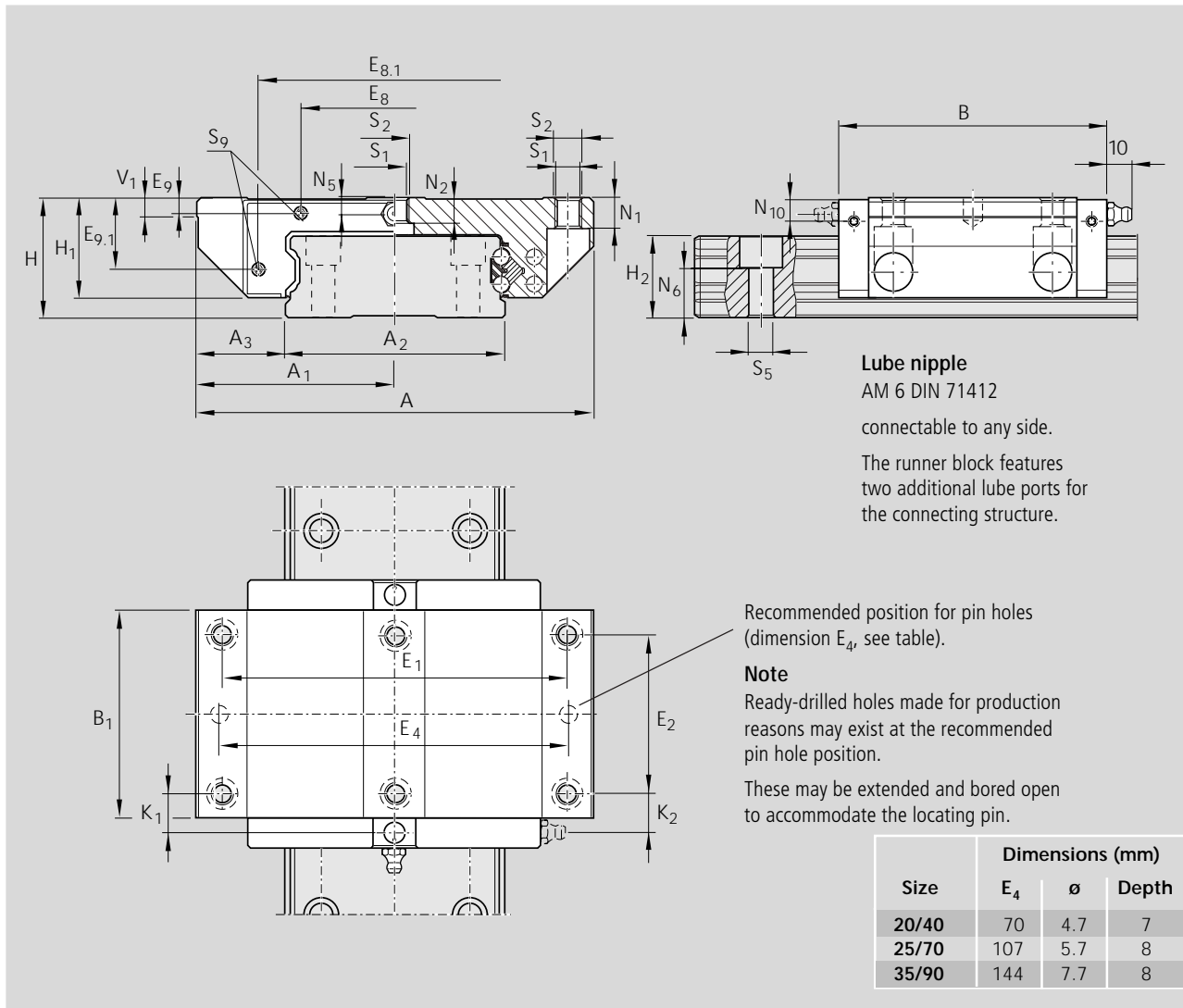

Size	Dimensions (mm)																		
	A	A_1	A_2	A_3	B	B_1	H	H_1	H_2	V_1	E_1	E_2	E_8	$E_{8.1}$	E_9	$E_{9.1}$	N_1	N_2	N_5
20/40	80	40	42	19.0	73	52.0	27	23.5	19.05	6.0	70	40	36.0	57.5	3.55	15.5	7.7	3.7	4.0
25/70	120	60	69	25.5	105	79.5	35	30.0	23.40	7.5	107	60	70.2	90.7	5.6	20.3	9.0	7.0	5.5
35/90	162	81	90	36.0	142	113.6	50	42.5	32.00	8.0	144	80	79.0	116.0	6.8	29.9	14.0	12.0	9.0

Size	Dimensions (mm)							Mass (kg)	Load capacities (N)		Moments (Nm)			
	$N_6^{\pm 0.5}$	N_{10}	S_1	S_2	K_1	K_2	S_9		C dyn.	C_0 stat.	M_t dyn.	M_{t0} stat.	M_L dyn.	M_{L0} stat.
20/40	13.2	5.5	5.4	M6	10.6	11.0	M2.5-3.5 deep	0.45	15 600	24 100	370	640	116	200
25/70	14.4	8.0	6.4	M8	15.4	16.3	M3-5 deep	1.70	30 400*	45 500	1 130	1 690	345	510
35/90	20.5	9.0	8.4	M10	22.8	24.8	M3-5 deep	3.70	58 200*	86 300	2 880	4 270	920	1 370

* 30 % higher dynamic load capacities and moments

STAR – Ball Rail® Systems

Wide Ball Rail® Systems

Guide Rail 1675-

Wide, for mounting from above

- Plastic mounting hole plugs are supplied along with the rail.
Reordering data: see table inset on right for part numbers.
 - For special applications:
Guide rails for steel mounting hole plugs, Part numbers: **1676-.5.-**
Steel mounting hole plugs to be ordered separately.
- A mounting jig with instruction leaflet is available for mounting steel mounting hole plugs.

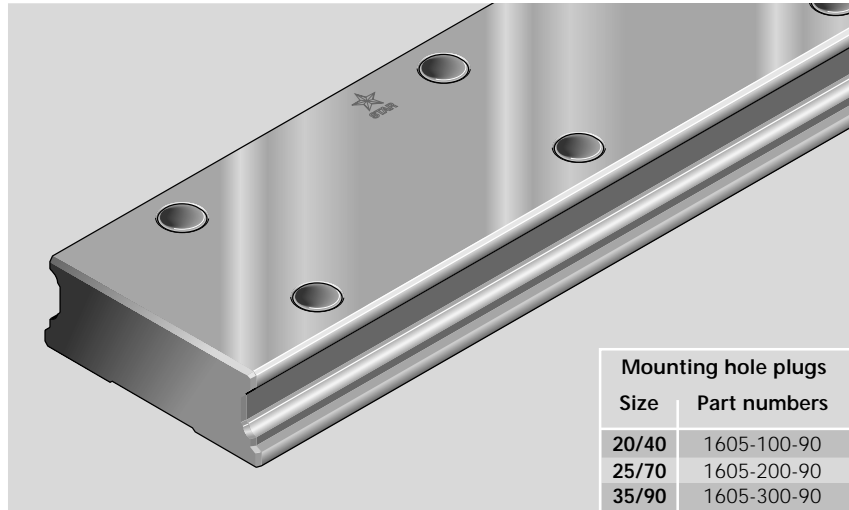

Mounting hole plugs	
Size	Part numbers
20/40	1605-100-90
25/70	1605-200-90
35/90	1605-300-90

Size	Part numbers Mounting jig
25/70	1619-210-40
35/90	1619-310-40

Special version:
Zinc-iron coating with yellow chromating
in accuracy class N.

Part numbers:

- 1674-.14-3. (end faces uncoated)
- 1674-.14-4. (end faces coated)

Part numbers

Size	Accuracy class	Guide Rail	
		One-piece Part number, Rail length L (mm)	Composite Part number, Number of sections Rail length L (mm)
20/40	P	1675-802-31,.....	1675-852-3,.....
	H	1675-803-31,.....	1675-853-3,.....
	N	1675-804-31,.....	1675-854-3,.....
25/70	P	1675-202-31,.....	1675-202-3,.....
	H	1675-203-31,.....	1675-203-3,.....
	N	1675-204-31,.....	1675-204-3,.....
35/90	P	1675-302-31,.....	1675-302-3,.....
	H	1675-303-31,.....	1675-303-3,.....
	N	1675-304-31,.....	1675-304-3,.....

Dimensions and masses

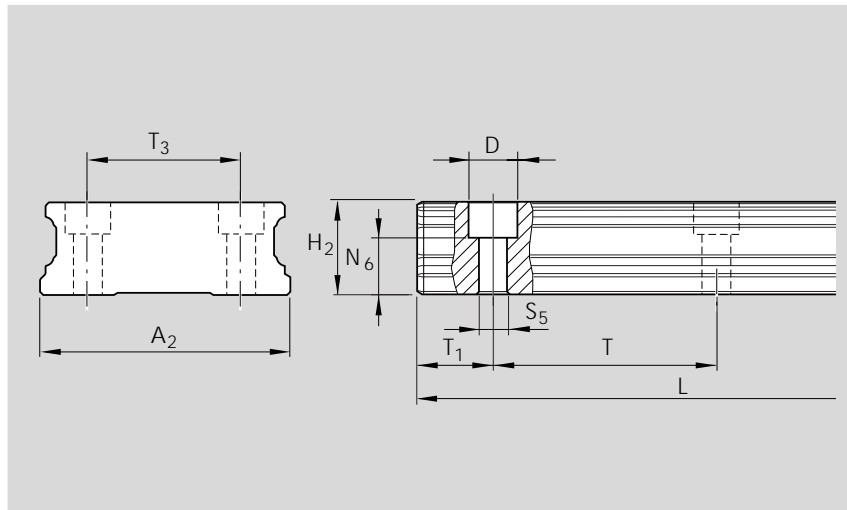

Size	Dimensions (mm)										Mass kg/m
	A ₂	H ₂	N ₆ ^{±0.5}	D	S ₅	T ₁₅ ^{±0.5}	T _{1min}	T	T ₃	L _{max}	
20/40	42	19.05	13.2	7.4	4.4	28	10	60	24	4 000	5.3
25/70	69	23.40	14.4	11.0	7.0	38	10	80	40	4 000	11.6
35/90	90	32.00	20.5	15.0	9.0	38	12	80	60	4 000	21.0

Ordering a guide rail

Ordering example 1:

Guide rail size 35/90,
accuracy class H,
rail length 1756 mm,
(21 · T, number of holes n_B = 22
giving 44 holes in 2 rows)
Ordering data: **1675-303-31, 1756 mm**

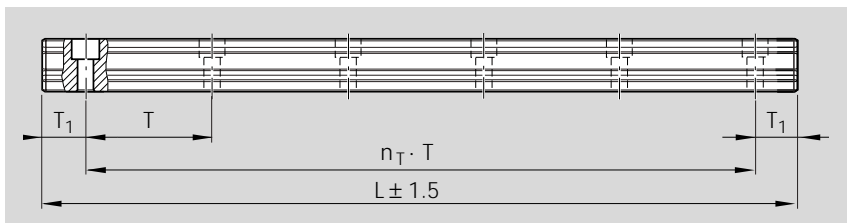

Intermediate lengths

Calculation of rail length L and ordering examples:

- The preferred dimension is T₁₅
- If T₁₅ cannot be used, then
 - Select an end space T₁ between T₁₅ and T_{1min}
 - Do not go below the minimum spacing T_{1min}!

Note

- T₁, T_{1min}, T₁₅ are the same at either end of the rail.

$$L = n_B \cdot T - 4$$

or

$$L = n_T \cdot T + 2 \cdot T_{15}$$

L = rail length (mm)

T = hole spacing*) (mm)

T₁₅ = preferred dimension*) (mm)

n_B = number of holes per row

n_T = number of spaces

*) see table for values

Ordering example 2 (up to L_{max}):

Guide rail size 35/90,
accuracy class P,
rail length 1676 mm,
(20 · T, preferred dimension T₁₅ = 38 mm;
number of holes n_B = 21 giving 42 holes
in 2 rows)

Ordering data:

Part number, length (mm)
T₁₅ / n_T · T / T₁₅ (mm)
1675-302-31, 1676 mm
38 / 20 · 80 / 38 mm

Rail lengths above L_{max} are made up of fitted rail sections mounted end to end.

Ordering example 3 (over L_{max}):

Guide rail size 35/90,
accuracy class P,
rail length 5036 mm, 2 sections
(62 · T, preferred dimension T₁₅ = 38 mm;
number of holes n_B = 63 giving 126 holes
in 2 rows)

Ordering data:

Part number and number of sections,
length (mm)
T₁₅ / n_T · T / T₁₅ (mm)
1675-302-32, 5036 mm
38 / 62 · 80 / 38 mm



STAR – Ball Rail® Systems

Wide Ball Rail® Systems

Guide rail 1677-

Wide, for mounting from below

Special version:

Zinc-iron coating with yellow chromating
in accuracy class N available on request.

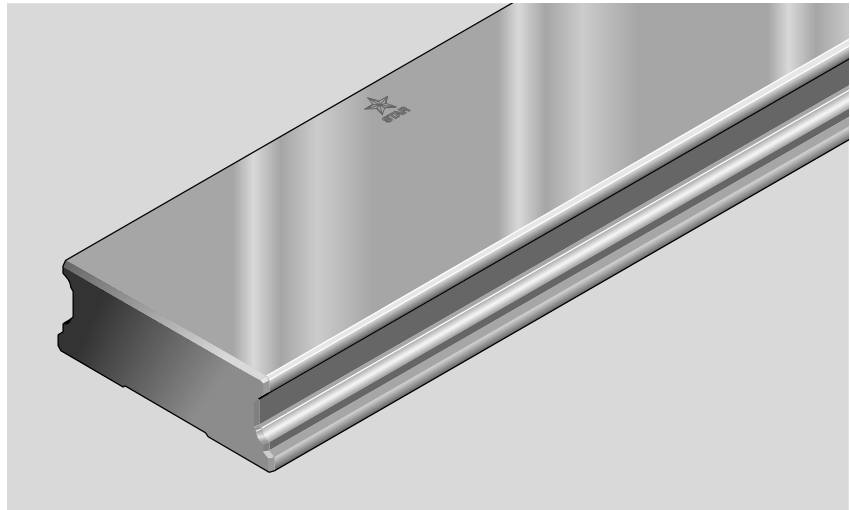

Part numbers

Size	Accuracy class	Guide Rail		Hole spacing T (mm)
		One-piece Part number, Rail length L (mm)	Composite Part number, Number of sections Rail length L (mm)	
20/40	P	1677-802-31,....	1677-852-3,....	60
	H	1677-803-31,....	1677-853-3,....	
	N	1677-804-31,....	1677-854-3,....	
25/70	P	1677-202-31,....	1677-202-3,....	80
	H	1677-203-31,....	1677-203-3,....	
	N	1677-204-31,....	1677-204-3,....	
35/90	P	1677-302-31,....	1677-302-3,....	
	H	1677-303-31,....	1677-303-3,....	
	N	1677-304-31,....	1677-304-3,....	

Dimensions and masses

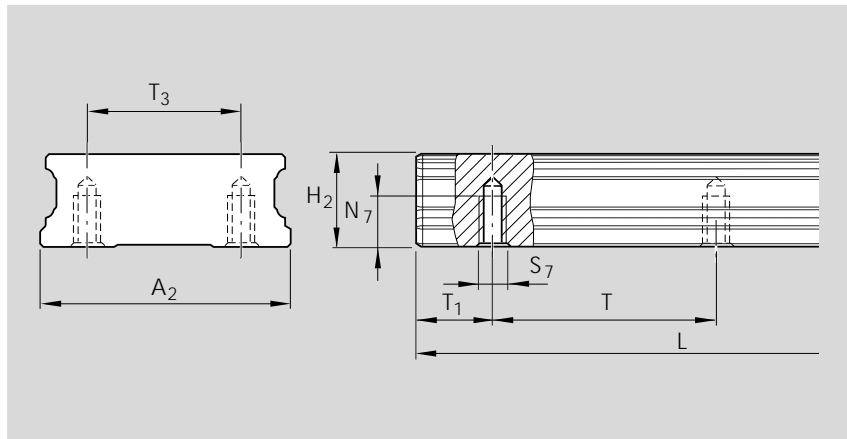

Size	Dimensions (mm)									Mass kg/m
	A ₂	H ₂	N ₇	S ₇	T ₁₅ ^{±0.5}	T _{1min}	T	T ₃	L _{max}	
20/40	42	19.05	7.5	M5	28	10	60	24	4 000	5.3
25/70	69	23.40	12.0	M6	38	10	80	40	4 000	11.6
35/90	90	32.00	15.0	M8	38	12	80	60	4 000	21.0

Ordering a guide rail

Ordering example 1:

Guide rail size 35/90,
accuracy class H,
rail length 1756 mm,
(21 · T, number of holes n_B = 22
giving 44 holes in 2 rows)
Ordering data: **1677-303-31, 1756 mm**

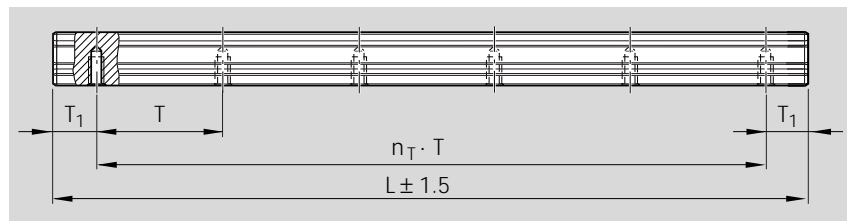

Intermediate lengths

Calculation of rail length L and ordering examples:

- The preferred dimension is T₁₅
- If T₁₅ cannot be used, then
 - Select an end space T₁ between T₁₅ and T_{1min}
 - Do not go below the minimum spacing T_{1min}!

Note

- T₁, T_{1min}, T₁₅ are the same at either end of the rail.

$L = n_B \cdot T - 4$ <p>OR</p> $L = n_T \cdot T + 2 \cdot T_{15}$	L = rail length (mm) T = hole spacing*) (mm) T ₁₅ = preferred dimension*) (mm) n _B = number of holes per row n _T = number of spaces *) see table for values
--	---

Ordering example 2 (up to L_{max}):

Guide rail size 35/90,
accuracy class P,
rail length 1676 mm,
(20 · T, preferred dimension T₁₅ = 38 mm;
number of holes n_B = 21 giving 42 holes
in 2 rows)

Ordering data:

Part number, length (mm)
T₁₅ / n_T · T / T₁₅ (mm)
1677-302-31, 1676 mm
38 / 20 · 80 / 38 mm

Rail lengths above L_{max} are made up of fitted rail sections mounted end to end.

Ordering example 3 (over L_{max}):

Guide rail size 35/90,
accuracy class P,
rail length 5036 mm, 2 sections
(62 · T, preferred dimension T₁₅ = 38 mm;
number of holes n_B = 63
giving 126 holes in 2 rows)

Ordering data:

Part number and number of sections,
length (mm)
T₁₅ / n_T · T / T₁₅ (mm)
1677-302-32, 5036 mm
38 / 62 · 80 / 38 mm



STAR – Ball Rail® Systems

Accessories, Standard Ball Rail® Systems

Lubrication plate

– Material: aluminum

Versions:

- Standard (for standard lube nipple)
- G 1/8 connection

Mounting:

The parts required for mounting on the runner block are supplied along with the optional attachments.

Size 25 - 65:

The runner block lube nipple can be used.

Size 15 and 20:

A funnel-type lube nipple with a knock-in spigot is supplied ready for insertion.

For mounting details, see "Mounting Instructions for Ball Rail® Systems".

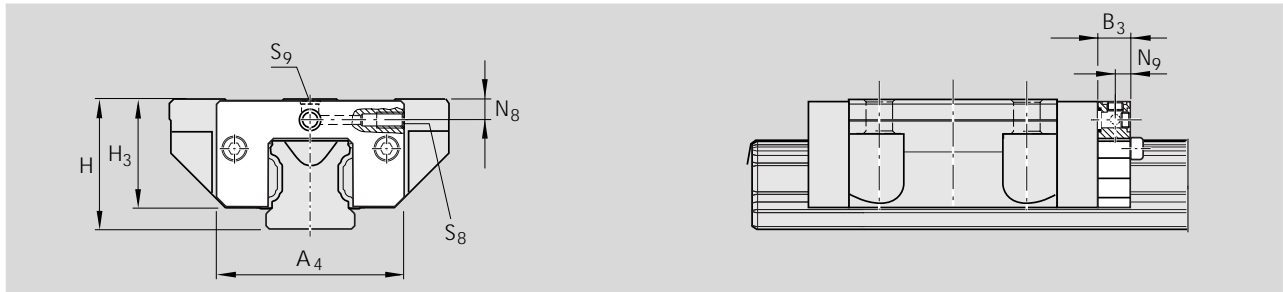
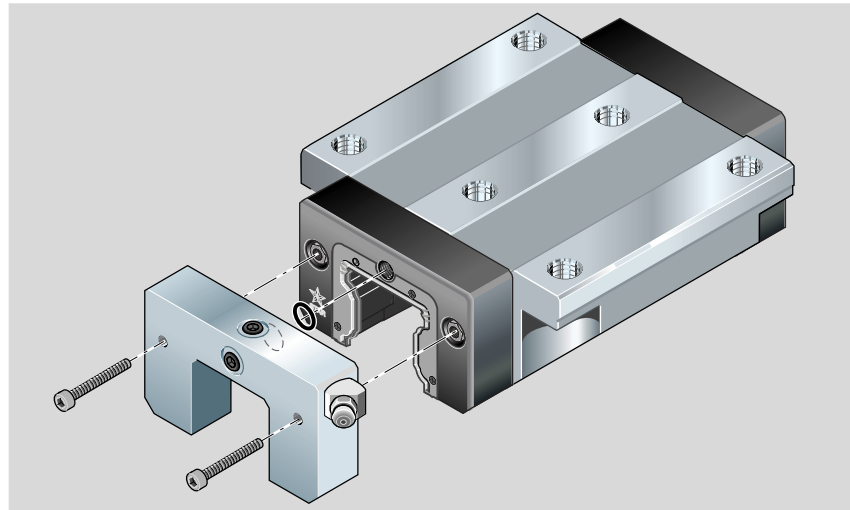

Standard lubrication plate

Part numbers, dimensions and masses.

Size	Part numbers	Dimensions (mm)								Mass (g)
		A ₄	B ₃	H	H ₃	N ₈	N ₉	S ₈	S ₉	
15	1620-111-20	32	11	24	19.0	3.4	5.5	∅3	M3	15
20	1620-811-20	42	12	30	24.8	3.5	6.0	∅3	M3	25
25	1620-211-20	47	12	36	28.3	6.0	6.0	M6	M3	30
30	1620-711-20	59	12	42	33.8	8.0	6.0	M6	M6	45
35	1620-311-20	69	12	48	39.1	8.0	6.0	M6	M6	60
45	1620-411-20	85	12	60	48.5	8.0	6.0	M6	M6	85
55	1620-511-20	98	12	70	56.0	9.0	6.0	M6	M6	115
65	1620-611-20	124	14	90	75.7	18.0	7.0	M8x1	M8x1	250

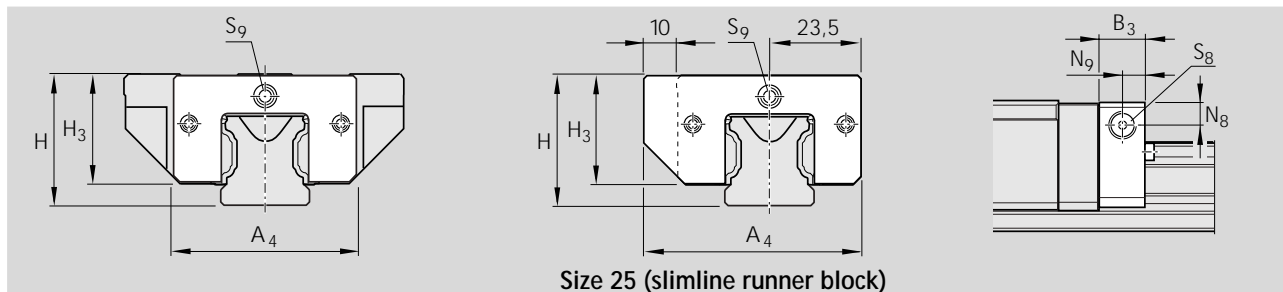

Size 25 (slimline runner block)

Lubrication plate G 1/8

Part numbers, dimensions and masses.

With slimline runner block size 25, remember that the lubrication plate will project at the side.

Size	Part numbers	Dimensions (mm)								Mass (g)
		A ₄	B ₃	H	H ₃	N ₈	N ₉	S ₈		
25	1620-211-30	57	16	36	28.3	7.0	8	G 1/8 - 8 tief	40	
30	1620-711-30	59	16	42	33.8	7.0	8	G 1/8 - 8 tief	59	
35	1620-311-30	69	16	48	39.1	8.0	8	G 1/8 - 8 tief	79	
45	1620-411-30	85	16	60	48.5	8.0	8	G 1/8 - 8 tief	112	
55	1620-511-30	98	16	70	56.0	9.0	8	G 1/8 - 8 tief	152	
65	1620-611-30	124	16	90	75.7	18.0	8	G 1/8 - 8 tief	285	



Scraper plate

- Material: corrosion resistant spring steel to DIN 17230 / EN 10088
- Finish: bright

Mounting:

The mounting screws are supplied with the scraper plate.

When mounting, ensure that there is a uniform gap between runner block and scraper plate.

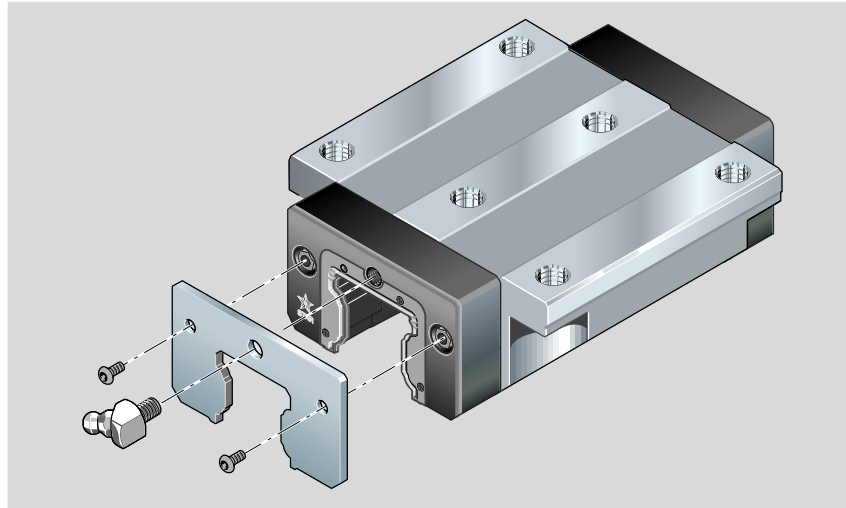

Scraper plates for guide rails with Rail Seal® cover strips.

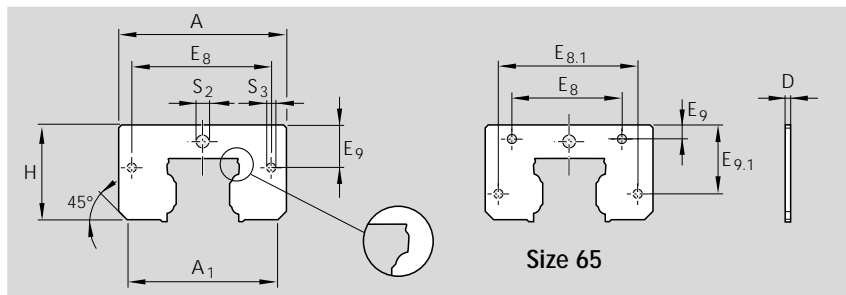
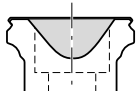

*) Scraper plates for guide rails without Rail Seal from size 35, Part numbers: 1620-.10-30

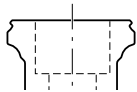

Size	Part numbers	Dimensions (mm)										Mass (g)
		A	A ₁	H	E ₈	E _{8.1}	E ₉	E _{9.1}	S ₂	S ₃	D	
15	1620-110-30	33	26.4	19.2	24.55	-	6.3	-	ø4	ø3.5	1.0	4
20	1620-810-30	42	40.0	24.8	32.4	-	6.8	-	ø4	ø4	1.0	6
25	1620-210-30	47	41.6	29.5	38.3	-	11.0	-	ø7	ø4	1.0	8
30	1620-710-30	59	52.8	34.7	48.4	-	14.1	-	ø7	ø4	1.0	12
35*	1620-310-40	69	60.9	40.1	58.0	-	17.0	-	ø7	ø4	1.0	16
45*	1620-410-40	85	76.7	50.0	70.0	-	20.5	-	ø7	ø5	2.0	50
55*	1620-510-40	98	89.8	56.4	80.0	-	21.8	-	ø7	ø6	2.0	65
65*	1620-610-40	124	113.2	74.7	76.0	100	10.0	52.5	ø9	ø5	2.5	140

Two-piece front seal

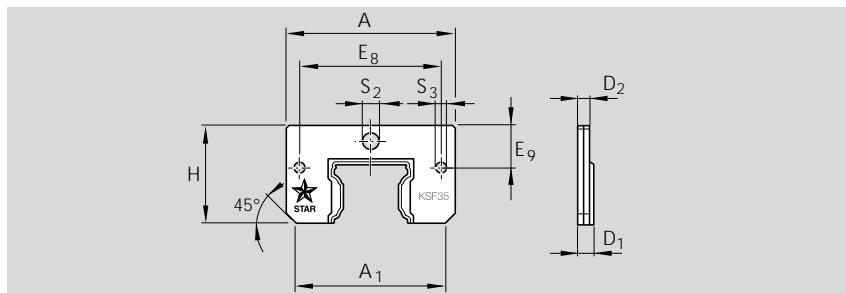

Size	Part numbers	Dimensions (mm)										Mass (g)
		A	A ₁	H	E ₈	E ₉	S ₂	S ₃	D ₁	D ₂		
15	1619-121-20	32	27	19.0	24.55	6.3	ø3.5	ø3.5	3.0	2.2	6	
20	1619-821-20	42	39	24.3	32.4	6.8	ø4	ø4	3.3	2.5	8	
25	1619-221-30	47	42	29.0	38.3	11.0	ø7	ø4	3.3	2.5	10	
30	1619-721-30	59	53	34.5	48.4	14.1	ø7	ø4	4.5	3.3	18	
35	1619-321-30	69	61	39.5	58.0	17.0	ø7	ø4	4.5	3.3	25	
45	1619-421-30	85	77	49.5	70.0	20.5	ø7	ø5	5.5	4.0	55	



STAR – Ball Rail® Systems

Accessories, Standard Ball Rail® Systems

Protective bellows

- Material: Bellows-type protective cover of polyurethane-coated polyester fabric
 - Aluminum lubrication plates
- The runner block lube nipple can be used.

Heat resistant bellows

- Material: Nomex fabric, metallized on both sides.
- Non combustible, non flammable
- Resistant to sparks, welding splashes and hot chips
- Temperature resistance:
Temperatures of up to 200°C near the protective metal coat possible.
Operating temperature for the entire bellows: 100°C.

Available in sizes 25-55.

The runner block lube nipple can be used.

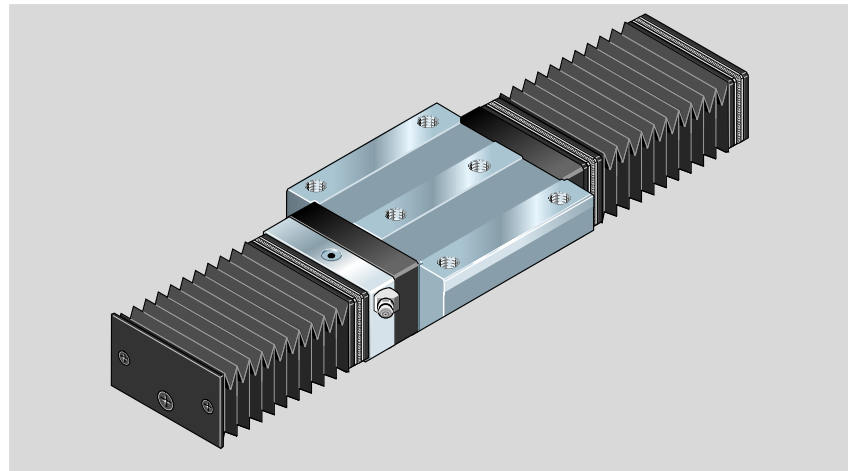

Part numbers, Bellows

Example: 1620-306-00, 36 folds

Standard	= 0
Fire resistant	= 5
Type 1 to 9	

Bellows size 35, standard version, type 6 (with FLU* and end plate), number of folds: 36

* FLU = front lube unit

Size	Typ 1 with lubrication plate and end plate		Typ 2 with mounting frame and end plate		Typ 3 with 2 lubrication plates	
	Typ 6 with FLU* and end plate	Number of folds	Number of folds	Number of folds	Typ 7 with 2 FLU*	Number of folds
15	1620-10.-00	...	1620-102-00	...	1620-10.-00	...
20	1620-80.-00	...	1620-802-00	...	1620-80.-00	...
25	1620-20.-00	...	1620-202-00	...	1620-20.-00	...
30	1620-70.-00	...	1620-702-00	...	1620-70.-00	...
35	1620-30.-00	...	1620-302-00	...	1620-30.-00	...
45	1620-40.-00	...	1620-402-00	...	1620-40.-00	...
55	1620-50.-00	...	1620-502-00	...	1620-50.-00	...
65	1620-60.-00	...	1620-602-00	...	1620-60.-00	...
25	1620-25.-00	...	1620-252-00	...	1620-25.-00	...
30	1620-75.-00	...	1620-752-00	...	1620-75.-00	...
35	1620-35.-00	...	1620-352-00	...	1620-35.-00	...
45	1620-45.-00	...	1620-452-00	...	1620-45.-00	...
55	1620-55.-00	...	1620-552-00	...	1620-55.-00	...

Size	Typ 4 with 2 mounting frames		Typ 5 with lubrication plate and mounting frame (MF)		Typ 9 Bellows, loose supply (spare part)	
	Number of folds	Number of folds	Typ 8 with FLU* and MF	Number of folds	Number of folds	Number of folds
15	1620-104-00	...	1620-10.-00	...	1600-109-00	...
20	1620-804-00	...	1620-80.-00	...	1600-809-00	...
25	1620-204-00	...	1620-20.-00	...	1600-209-00	...
30	1620-704-00	...	1620-70.-00	...	1600-709-00	...
35	1620-304-00	...	1620-30.-00	...	1600-309-00	...
45	1620-404-00	...	1620-40.-00	...	1600-409-00	...
55	1620-504-00	...	1620-50.-00	...	1600-509-00	...
65	1620-604-00	...	1620-60.-00	...	1600-609-00	...
25	1620-254-00	...	1620-25.-00	...	1600-259-00	...
30	1620-754-00	...	1620-75.-00	...	1600-759-00	...
35	1620-354-00	...	1620-35.-00	...	1600-359-00	...
45	1620-454-00	...	1620-45.-00	...	1600-459-00	...
55	1620-554-00	...	1620-55.-00	...	1600-559-00	...



Mounting instructions

The bellows are delivered preassembled ready for installation, complete with the screws required for attachment to the guide rail.

In types 1 and 2, thread size M4 10 mm deep and countersunk 2 x 45° must be tapped in each end face of the rail.

Size 25 - 65:

The runner block lube nipple can be used.

Size 15 and 20:

A funnel-type lube nipple with knock-in spigot is supplied.

For mounting details, see "Mounting Instructions for Lubrication Plates and Bellows".

**Dimensions:
Bellows**

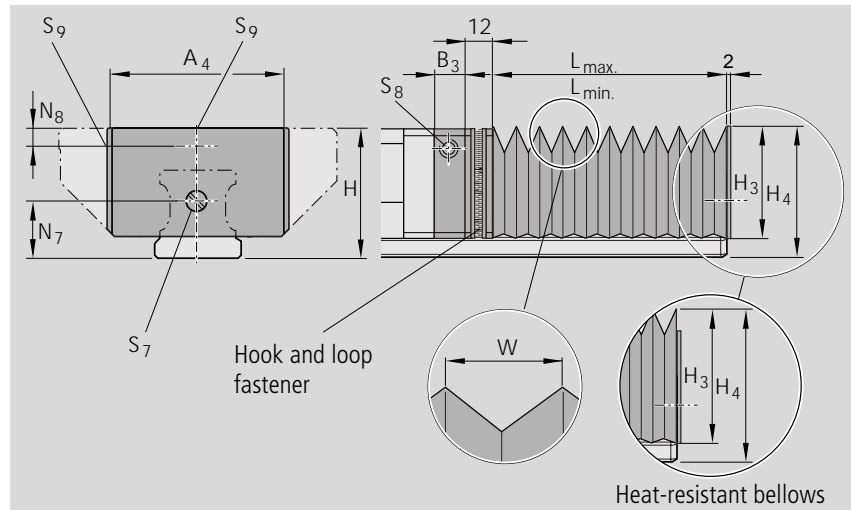

Size	Dimensions (mm)										Factor	
	A ₄	B ₃	H	H ₃	H ₄	N ₇	N ₈	S ₇	S ₈	S ₉	W	U
15	45	11	24	26.5	31.5	11	3.4	M4	∅3	M3	19.9	1.18
20	42	12	30	24.0	29.2	13	3.5	M4	∅3	M3	10.3	1.33
25	45	12	36	28.5	35.0	15	6.0	M4	M6	M3	12.9	1.32
30	55	12	42	34.0	41.0	18	8.0	M4	M6	M6	15.4	1.25
35	64	12	48	39.0	47.0	22	8.0	M4	M6	M6	19.9	1.18
45	83	12	60	49.0	59.0	30	8.0	M4	M6	M6	26.9	1.13
55	96	12	70	56.0	69.0	30	9.0	M4	M6	M6	29.9	1.12
65	120	14	90	75.0	89.0	40	18.0	M4	M8x1	M8x1	40.4	1.08

**Dimensions:
Heat-resistant bellows**

Size	Dimensions (mm)										Factor	
	A ₄	B ₃	H	H ₃	H ₄	N ₇	N ₈	S ₇	S ₈	S ₉	W	U
25	62	12	36	39.0	44.5	15	6.0	M4	M6	M3	25.9	1.25
30	67	12	42	42.0	47.5	18	8.0	M4	M6	M6	25.9	1.25
35	76	12	48	47.0	54.0	22	8.0	M4	M6	M6	29.9	1.21
45	90	12	60	55.0	64.0	30	8.0	M4	M6	M6	32.9	1.18
55	104	12	70	63.0	75.0	30	9.0	M4	M6	M6	37.9	1.16

Bellows design formulas

$L_{max} = (\text{Stroke} + 30) \cdot U$ $L_{min} = L_{max} - \text{Stroke}$ $\text{No. of folds} = \frac{L_{max}}{W} + 2$	L_{max} = Bellows extended L_{min} = Bellows compressed Stroke in mm U = Calculation factor W = Maximum extension (mm)
--	--

Rail length formula

$L = L_{min} + L_{max} + L_A$	L = Rail length (mm)
-------------------------------	------------------------



STAR – Ball Rail® Systems

Accessories, Wide Ball Rail® Systems

Wide lubrication plate, G 1/8

– Material: aluminum

Mounting:

The parts required for mounting on the runner block are supplied along with the optional attachments.

The runner block lube nipple can be used.

For mounting details, see "Mounting Instructions for Ball Rail® Systems".

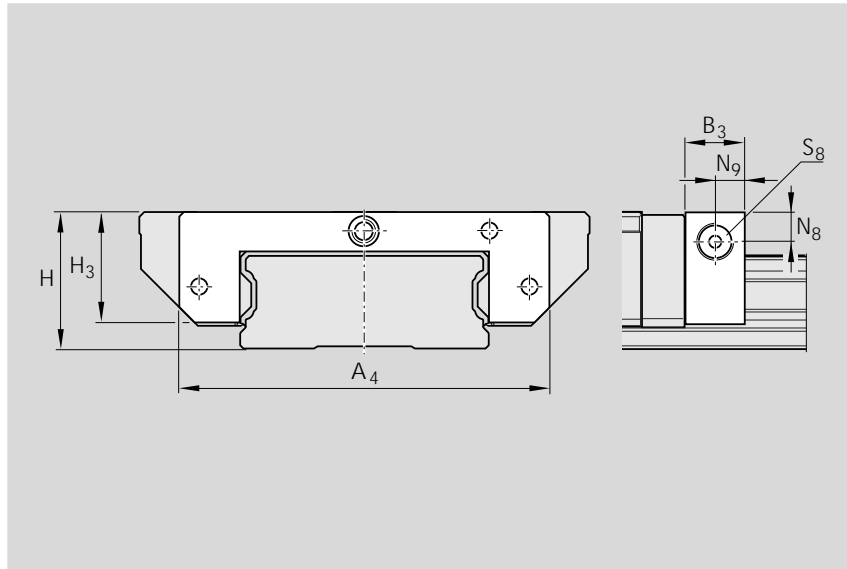

Size	Part numbers	Dimensions (mm)							Mass (g)
		A ₄	B ₃	H	H ₃	N ₈	N ₉	S ₈	
25/70	1670-211-30	101	16	36	29	7.7	8	G 1/8 - 8 tief	65
35/90	1670-311-30	129	16	42	41	8.3	8	G 1/8 - 8 tief	120

Wide scraper plate

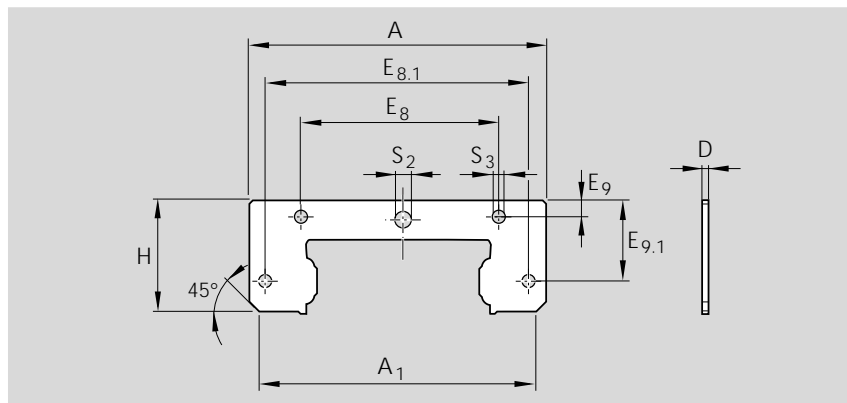

Size	Part numbers	Dimensions (mm)										Mass (g)
		A	A ₁	H	E ₈	E _{8.1}	E ₉	E _{9.1}	S ₂	S ₃	D	
25/70	1670-210-00	101	92.7	28.6	70.2	90.7	5.1	19.7	∅7	∅4	1.0	14
35/90	1670-310-00	129	124.2	40.8	79.0	116	5.6	28.7	∅7	∅4	1.0	25



Wide bellows

- Material: Bellows-type protective cover of polyurethane-coated polyester fabric
- The runner block lube nipple can be used.

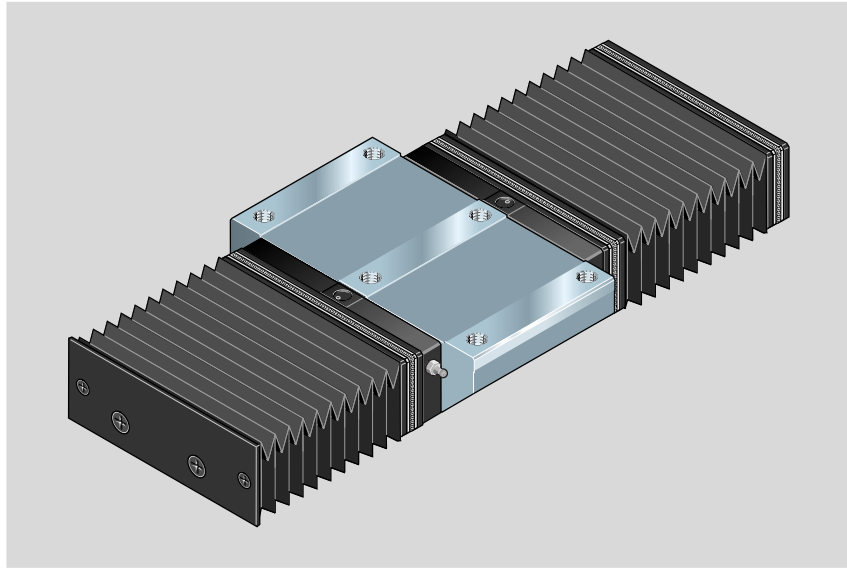

Part numbers, Bellows

Ordering example for bellows

Size 35/90, Type 2,
Number of folds: 36
1670-302-00, 36 folds

Size	Typ 2		Typ 4		Typ 9	
	with mounting frame and end plate	Number of folds	with 2 mounting frames	Number of folds	Bellows, loose supply (spare part)	Number of folds
25/70	1670-202-00	...	1670-204-00	...	1670-209-00	...
35/90	1670-302-00	...	1670-304-00	...	1670-309-00	...

Mounting instructions

The bellows are delivered preassembled ready for installation, complete with the screws required for attachment to the guide rail.

In types 2 and 4, two threads size M4 10 mm deep and countersunk 2 x 45° must be tapped in each end face of the rail.

The runner block lube nipple can be used.

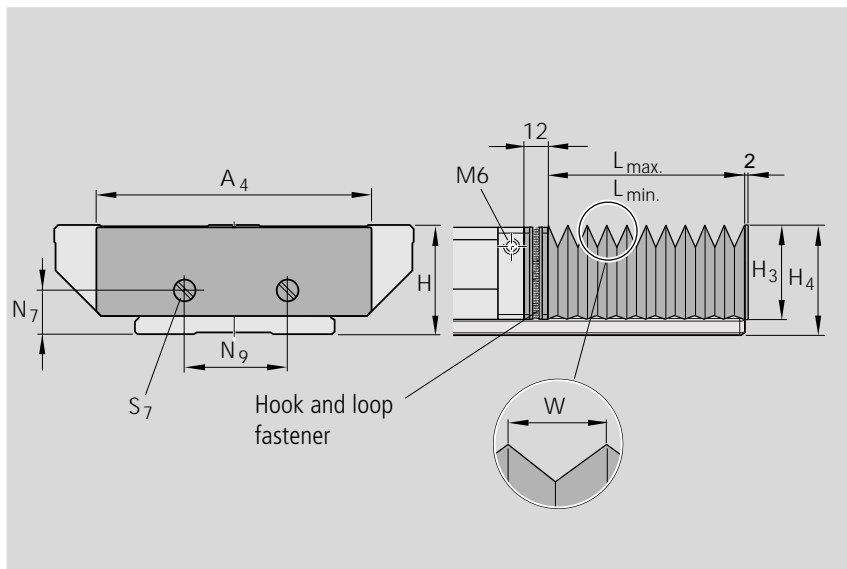

Dimensions: Bellows

Size	Dimensions (mm)								Factor U
	A ₄	H	H ₃	H ₄	N ₇	N ₉	S ₇	W	
25/70	101	35	29	35	14.0	26	M4	12.9	1.25
35/90	128	50	42	49	21.5	40	M4	19.9	1.18



STAR – Ball Rail® Systems Accessories, Wide Ball Rail® Systems

Bellows design formulas

$L_{max} = (\text{Stroke} + 30) \cdot U$ $L_{min} = L_{max} - \text{Stroke}$ $\text{No. of folds} = \frac{L_{max}}{W} + 2$	L_{max} = Bellows extended L_{min} = Bellows compressed Stroke in mm U = Calculation factor W = Maximum extension (mm)
--	--

Rail length formula

$L = L_{min} + L_{max} + L_A$	L = Rail length (mm)
-------------------------------	------------------------

Mounting Instructions for Accessories

For details of how to mount accessories such as the lubrication plate, bellows etc, see Mounting Instructions for Ball Rail® Systems RDEFI 82 270.



Accessories, General

Wedge profile for Ball Rail® Systems

Lateral retention

- Material: steel
- Finish: black

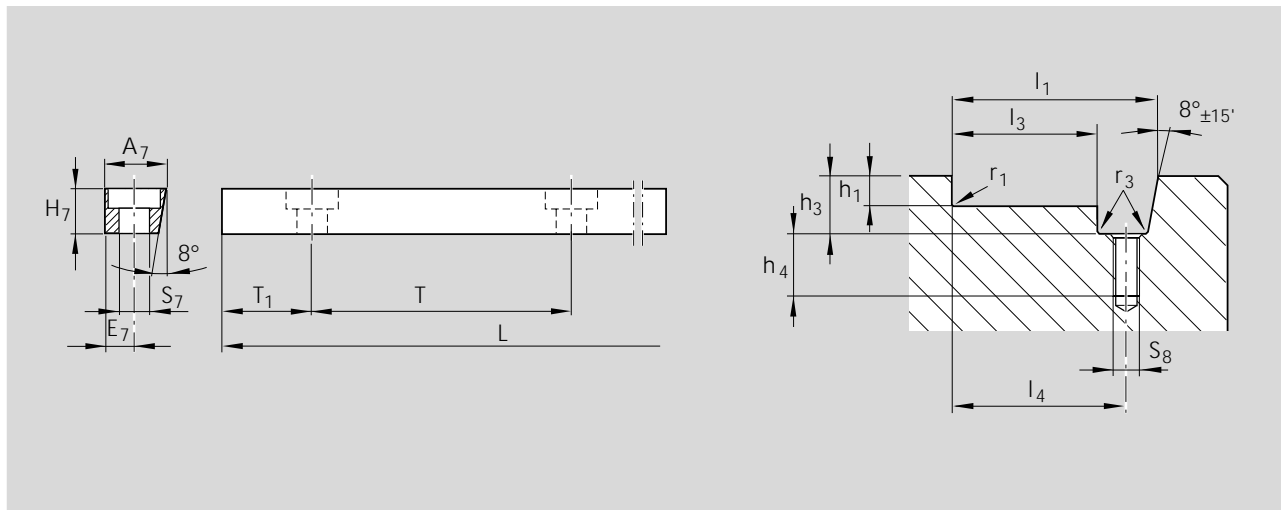
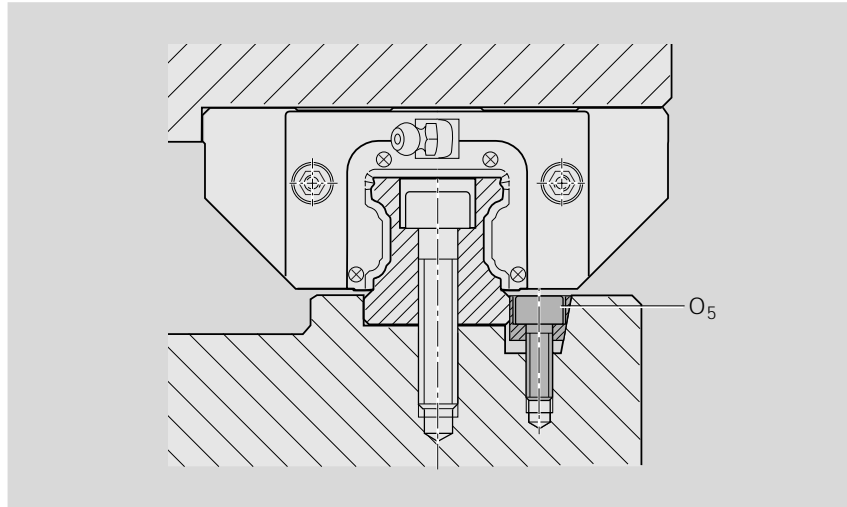

Part numbers and dimensions

Size	Part numbers	Wedge profile							Wedge profile groove									
		Dimensions (mm)							Dimensions (mm)									
		A ₇	E ₇	H ₇	S ₇	T	T ₁	L	O ₅	h ₁	h ₃	h ₄	l ₁	l ₃	l ₄	S ₈	r ₁	r ₃
15	1619-200-01	12	6	10	5.5	60	28.5	957	M5x20	-0.2	+1	+2	±0.05	-0.1	±0.1		max.	max.
20										3.5	12.5	15	27	15	21	M5	0.4	0.5
25										4	12.5	15	32	20	26	M5	0.5	0.5
30										5	12.5	15	35	23	29	M5	0.8	0.5
35										5	12.5	15	40	28	34	M5	0.8	0.5
45	1619-400-01	19	9	16	9.0	105	51.0	942	M8x25	8	19.0	16	64	45	54	M8	0.8	0.5
55										10	19.0	16	72	53	62	M8	1.2	0.5
65										10	19.0	16	82	63	72	M8	1.2	0.5

STAR – Ball Rail® Systems

Accessories, General

Funnel-type lube nipple

(Supplied as standard)

Part number
8417-004-09

Hydraulic-type lube nipple

(Supplied as standard)

Part number
8417-007-02

Part number
8417-008-02

Reducing adapters

Part number
8455-030-34

for tube
ø 6 mm

Part number
8455-030-37

for tube
ø 4 mm

Part number
8455-030-38

Extension

Part number
8455-030-69

Swiveling screw fitting

Part number
8417-018-09



Accessories, General

Fittings for plastic hoses

For runner blocks without scraper plates

Straight fitting

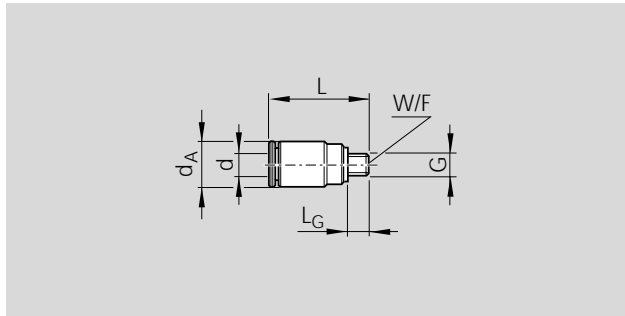

Part numbers	Dimensions (mm)					
	d _A	d	L	W/F	G	L _G
8417-010-09	5.8	3	12.5	1.5	M3	3
8417-011-09	7.8	3	13.5	2.0	M5	4

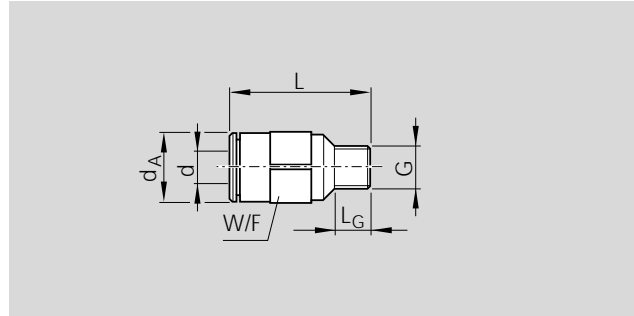

Part numbers	Dimensions (mm)					
	d _A	d	L	W/F	G	L _G
8417-013-09	11.0	4	21	10	M6x1	5.5
8417-014-09	13.5	6	21	12	M6x1	5.5

Elbow fitting

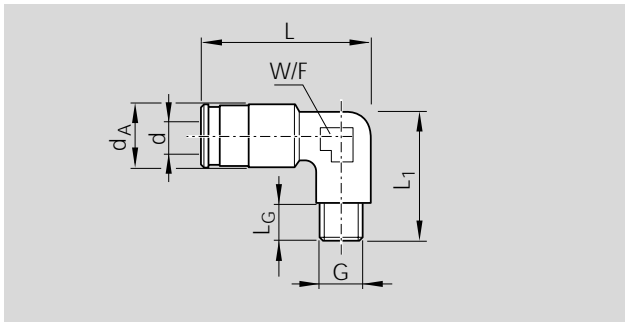

Part numbers	Dimensions (mm)						
	d _A	d	L	L ₁	W/F	G	L _G
8417-016-09	11.0	4	24	19	9	M6x1	5.5
8417-017-09	13.5	6	27	21	10	M6x1	5.5

Rotary elbow fitting

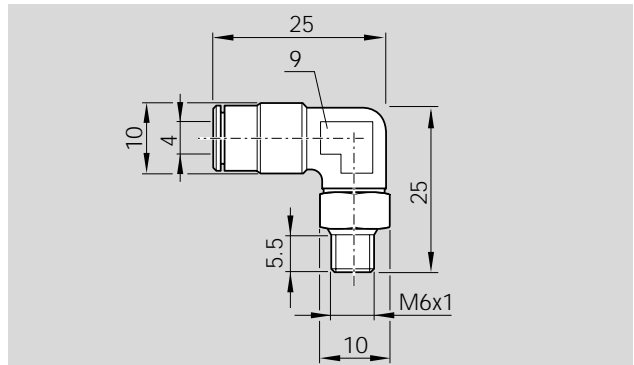

Part number
8417-015-09

Swiveling elbow fitting

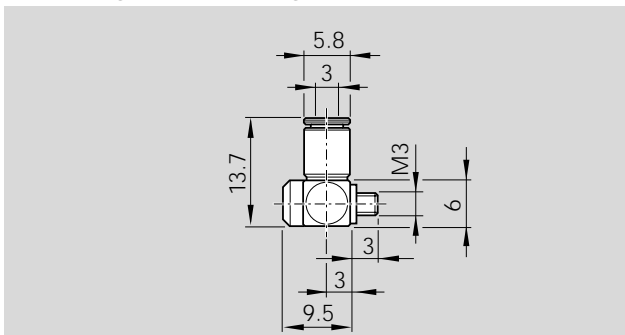

Part number
8417-012-09

STAR – Ball Rail® Systems Maintenance and Lubrication

Maintenance

Dirt can settle and encrust on guide rails, especially when these are not enclosed. To ensure that seals and Rail Seal® cover strips will retain their functionality, this dirt must be removed at regular intervals.

It is advisable to run the machine through a full "cleaning cycle" over the entire installed rail length at least twice a day, but no later than the end of every 8-hour shift. Always run a cleaning cycle before shutting down the machine.

Lubrication

Star Ball Rail® Systems are delivered filled with an anti-corrosion agent. Either oil or grease can be used as a lubricant.

Before start-up, make sure the system has sufficient initial lubrication.

Grease Lubricants

We recommend a grease lubricant to DIN 51825:

- K2K
 - For higher loads:
 - KP2K
Consistency class NLGI 2 to DIN 51818
- Observe the manufacturer's instructions.

Short stroke.

Stroke < 2 runner block lengths:

- Provide 2 lube ports per runner block and lubricate these!

Stroke < 0.5 runner block length:

- Provide 2 lube ports per runner block and lubricate these!
- Move the runner block 2x runner block length per lubricating cycle. If this is not possible, please consult Star.

Lubricant quantities as per Table 1.

Apply the specified lubricant quantity per lube port.

Size	Grease lubricants	
	Initial lubrication partial quantity (cm ³)	In-service lubrication (cm ³)
15	0.4 (x 3)	0.4
20	0.7 (x 3)	0.7
25	1.4 (x 3)	1.4
30	2.2 (x 3)	2.2
35	2.2 (x 3)	2.2
45	4.7 (x 3)	4.7
55	9.4 (x 3)	9.4
65	15.4 (x 3)	15.4
20/40	1.0 (x 3)	1.0
25/70	1.4 (x 3)	1.4
35/90	2.7 (x 3)	2.7

Table 1

Size	In-service lubrication intervals under normal operating conditions
	Travel (km)
	Load ≤ 0,15 C
15	1000
20	1000
25	1000
30	1000
35	500
45	250
55	150
65	100

Table 2

Size	Oil Lubrication Initial and in-service lubrication (cm ³)
15	0.4
20	0.7
25	0.8
30	1.1
35	1.2
45	2.2
55	3.6
65	6.0
20/40	0.7
25/70	1.1
35/90	1.8

Table 3

Always lubricate runner blocks before start up (initial lubrication)

Initial lubrication requires a total of three times the partial quantity given in Table 1:

1. Apply the first partial quantity of lubricant as per Table 1 to runner block.
2. Slide runner blocks back and forth over at least three times the block length for three full cycles.
3. Repeat steps 1. and 2. twice more
4. Check whether a film of lubricant is visible on the guide rail.

In-service lubrication of runner blocks

- Once the in-service lubrication interval as given in Table 2 is reached, apply the lubricant quantity as stated in Table 1. If the equipment is to operate in an environment subject to dirt or vibration and shock loads, etc., we recommend shortening the in-service lubrication interval.

The smaller the load, the longer the intervals between in-service lubrication will be.

Oil lubricants

 Add the entire oil quantity at one time!

Lubrication interval ≤ 40000 m



One-point oil lubrication

Notes

Recommended interval between two pulses: 10 seconds.

Example for size 45:

4 pulses of 0.6 cm³ each in 50 seconds.

The quantities listed in the table are valid for:

$F \leq 0.3 C$

$v \leq 1 \text{ m/s}$

Lubrication interval $\leq 40,000 \text{ m}$

If the equipment is to operate in an environment subject to dirt or vibration and shock loads, etc., we recommend shortening the in-service lubrication interval.

Size	Lubricant quantities for one-point oil lubrication	
	Oil lubricant quantity / pulse (cm ³)	Pulses per lube cycle
15	0.6	1
20	0.6	2
25	0.6	2
30	0.6	2
35	0.6	2
45	0.6	4
55	1.5	3
65	1.5	4
20/40	0.6	2
25/70	0.6	2
35/90	0.6	3

Table 4

Stroke > 2 runner block lengths:

– Provide 1 lube port per runner block.

Oil lubricant to ISO VG 220.

Lubricant quantities to Table 4.

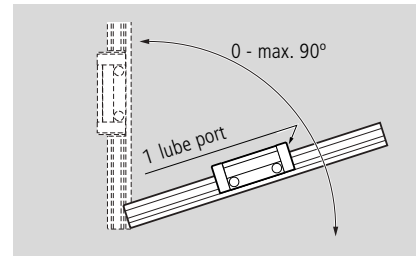
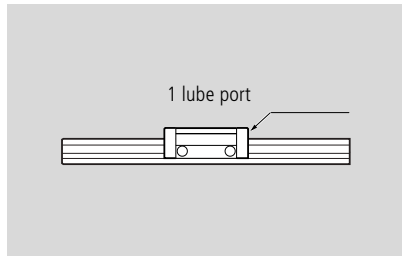

Stroke < 2 runner block lengths:

- Provide 2 lube ports per runner block.

Oil lubricant to ISO VG 220.

Lubricant quantities to Table 4.

Apply the specified lubricant quantity per lube port.

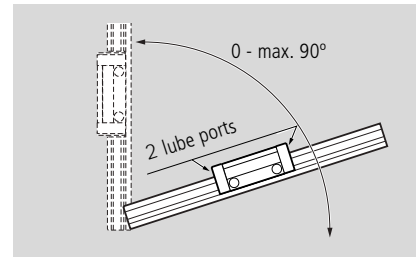
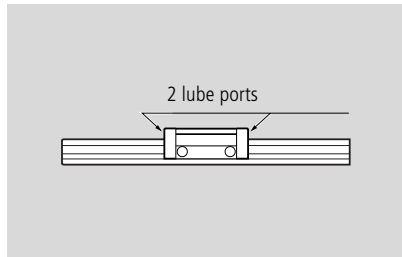

Installation at an angle about the centerline

Stroke < 2 runner block lengths:

– Provide 2 lube ports per runner block.

Add the lubricant quantity as specified in Table 4 in one pulse.

If this is not possible, please consult STAR.

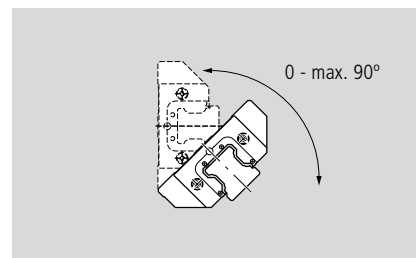
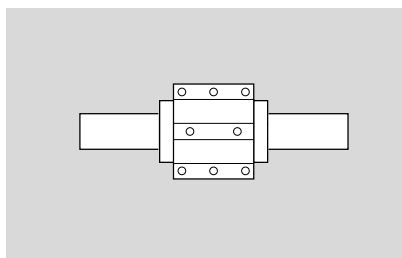

Special Lube Ports

Lube ports mounted on the top (1) or on the sides (2) are available on request.

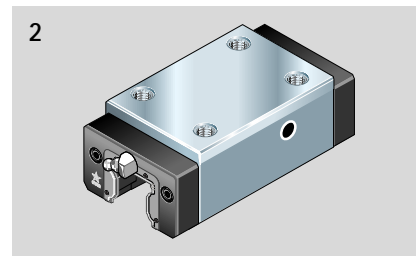
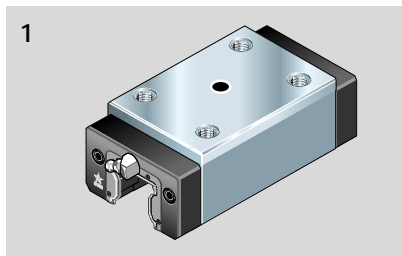

STAR – Ball Rail® Systems Front Lube Unit

Advantages during mounting and in service:

- Up to 10,000 km travel
- Only initial lubrication of the runner block necessary
- Front Lube Units at both runner block ends
- Minimal lubricant loss
- Reduced oil consumption
- No lubrication lines
- Max. operating temperature 60C°

▶ Ports provided at end and side for convenient refilling using lube nipple

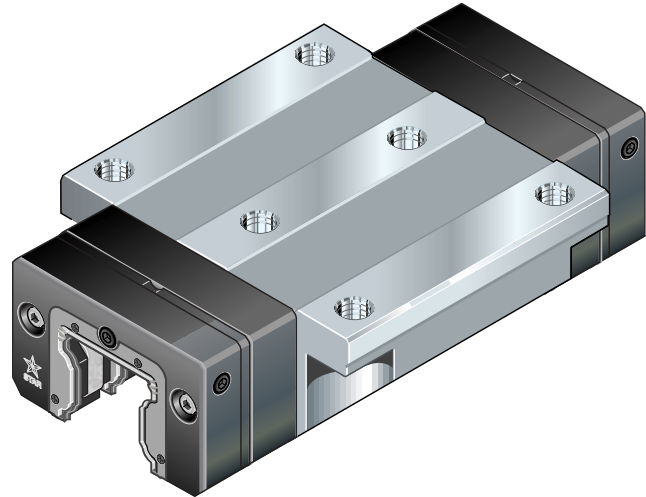

▶ Lube port on end face also suitable for lubricating runner block with grease

Size	Travel under normal operating conditions Travel (km)
	Load ≤ 0,15 C
15	10000
20	10000
25	10000
30	10000
35	4000
45	2500
55	1500
65	1000

STAR – Ball Rail® Systems

Runner block with two front lubrication units

Oil consumption comparison (Ball Rail® System size 25)

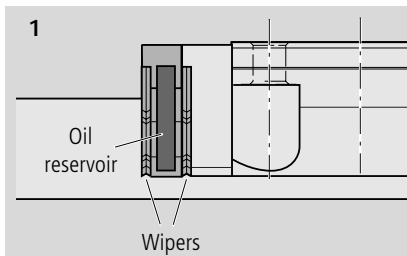

Front lubrication units	Lubricant quantity per lubrication cycle (cm ³)	Travel (m)	Consumption (cm ³ /km)
without	1.2	20 000	0.06 ! 100 %
with	5.2	5 000 000	0.00104 ! 1.73 %

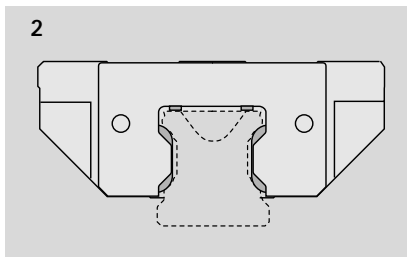

Specially designed oil distribution channels ensure that lubricant is applied only where needed: directly to the ball tracks and the guide rail surfaces (2).

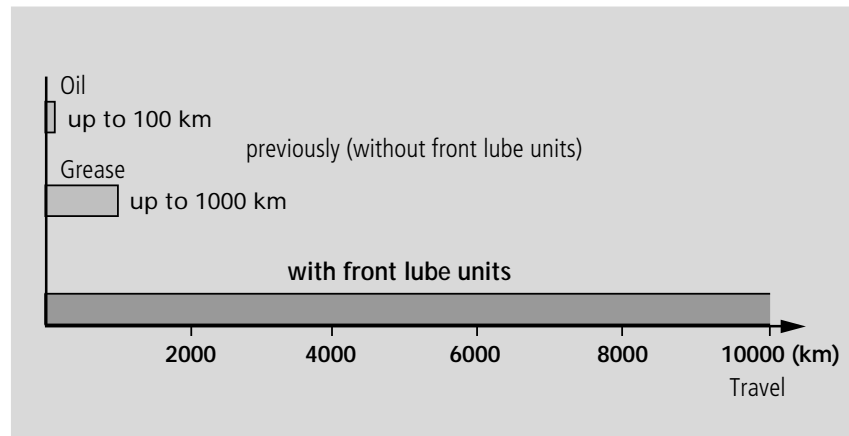

Front Lube Units for Ball Rail® Systems

- Material: special plastic.

Mounting instructions:

Comes complete with coated mounting screws and lubricating nipple.

Front Lube Units with the part numbers stated below: ...-00 are supplied ready-filled with oil and can be mounted immediately.

*Also available with dry reservoir for special lubricants.

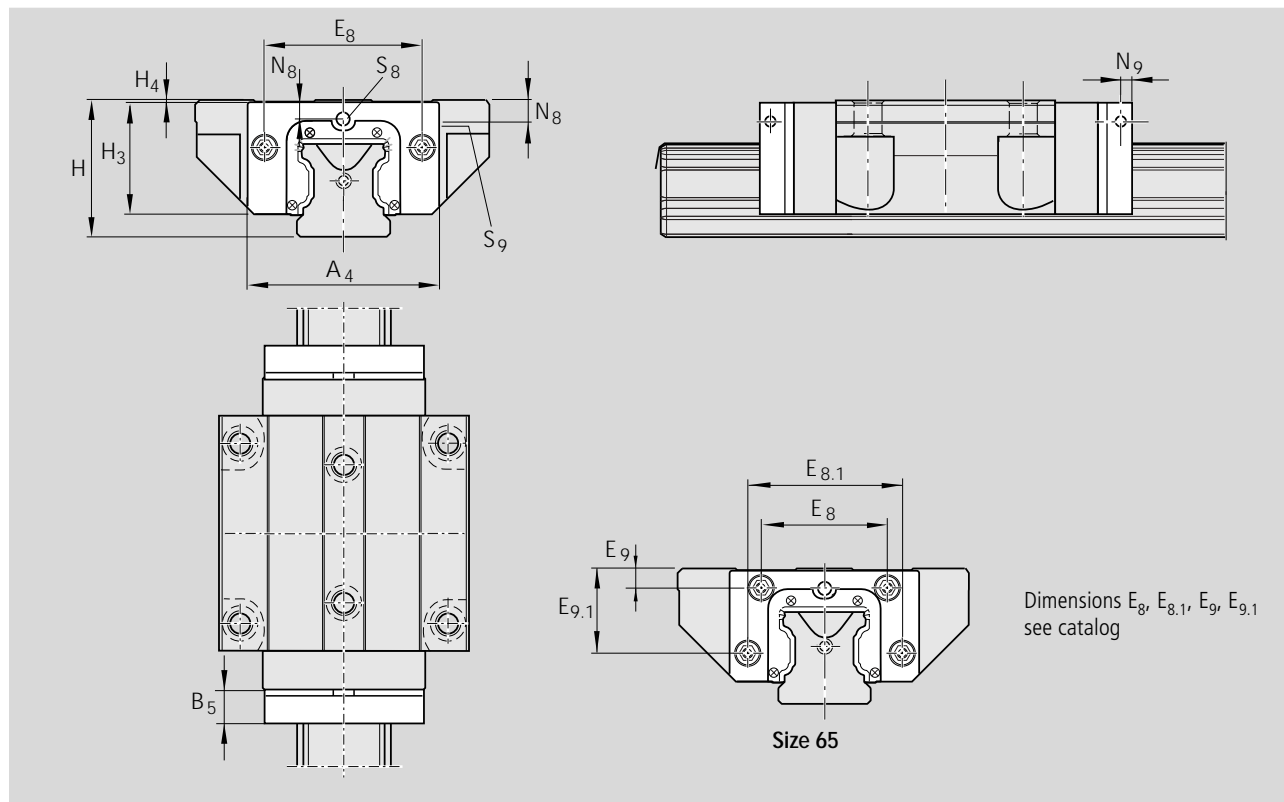
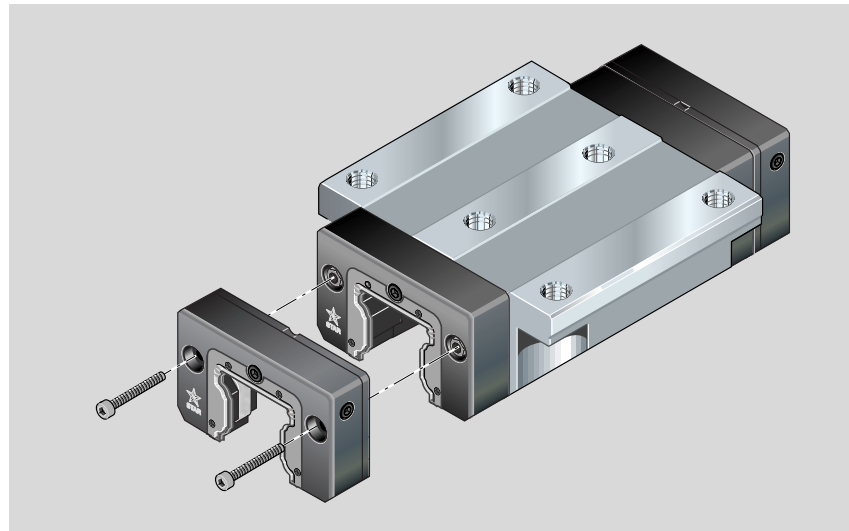

Part numbers, dimensions.

Size	Part numbers	Dimensions (mm)										Oil (cm ³)
		A ₄	B ₅	H	H ₃	H ₄	N ₈	N ₉	S ₈	S ₉		
15	1619-125-00	31.8	11.5	24	19.2	0.20	3.4	5	M3	M3	1.00	
20	1619-825-00	43.0	12.5	30	24.8	0.50	3.4	5	M3	M3	2.20	
25	1619-225-00	47.0	13.0	36	29.3	0.50	5.2	5	M6	M6	2.60	
30	1619-725-00	58.8	14.5	42	34.8	0.75	5.5	6	M6	M6	3.85	
35	1619-325-00	69.0	16.0	48	39.8	0.55	6.6	6	M6	M6	5.70	
45	1619-425-00	84.0	17.0	60	49.8	0.50	8.0	7	M6	M6	9.60	
55	1619-525-00	99.0	18.0	70	56.8	0.75	8.5	8	M6	M6	14.50	
65	1619-625-00	124.2	19.0	90	75.8	1.00	15.2	8	M8	M8	30.00	
20	1619-826-00	41.0	12.5	28	22.8	0.50	2.4	-	M3	-	1.8	
25	1619-226-00	47.0	13.0	33	26.3	0.50	3.8	5	M6	M3	2.5	

Ball Rail® Systems, low profile:
 Sizes 20 and 25 in preparation.

