

## FEATURES

- The valve offers full environmental protection against the ingress of liquids, dusts and other foreign matter (environmentally protected construction).
- Version can be installed in all sensitive zones (white rooms, etc..)

## GENERAL

Fluid	Air or neutral gas, filtered, lubricated or not
Operating pressure	0 to 10 bar
Pilot pressure	2 to 10 bar
Ambient temperature	-25°C to +60°C
Flow (Qv at 6 bar)	See "specifications"

## CONSTRUCTION

Body	Black anodized aluminium
Internal parts	Zinc diecasting, steel, POM (polyacetal), aluminium
Seals	NBR (nitrile) and PUR (polyurethane)

## SPECIFICATIONS

symbol function	operator		pipe size	flow		catalogue number
	pilot (12)	return (10)		at 6 bar l/min (ANR)	Kv coef.	
	Air operated	Spring	G 1/4	860	12,5	<b>G551A105</b>
			G 1/2	3800	52,5	<b>G553A105</b>
	Air operated	Air operated	G 1/4	860	12,5	<b>G551A106</b>
			G 1/2	3800	52,5	<b>G553A106</b>

Note: do not connect the pressure supply to the exhaust port 3. For a "distributing" function or use in NO function, contact us.

## ACCESSORIES - (identical for 3/2 and 5/2 spool valves)

- Supply rail (1) (supplied with seals and banjo bolts, without mounting brackets).
- Set of 2 mounting angle brackets (2) for supply rail, catalogue number: **88100049** (series 551) - **88100773** (series 553)

supply rail for « n » valves	catalogue number	
	551	553
2	<b>88100034</b>	<b>88100759</b>
3	<b>88100035</b>	<b>88100760</b>
4	<b>88100036</b>	<b>88100761</b>
5	<b>88100037</b>	<b>88100762</b>
6	<b>88100038</b>	<b>88100763</b>
7	<b>88100039</b>	<b>88100764</b>
8	<b>88100040</b>	<b>88100765</b>

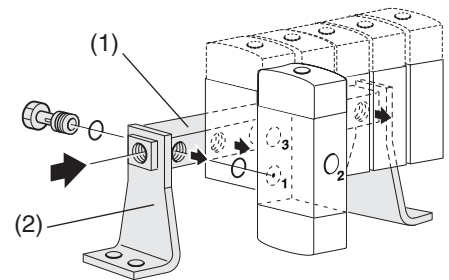

(1) or (3) supply rail  
(2) mounting brackets (x2)

- Supply rail with isolation valves (3) with mounting brackets (2) allows the isolation of one or more valves from the general pressure supply

supply rail G 1/4 for « n » valves series 551	catalogue number
2	<b>88100915</b>
3	<b>88100916</b>
4	<b>88100917</b>
5	<b>88100918</b>
6	<b>88100919</b>
7	<b>88100920</b>
8	<b>88100921</b>

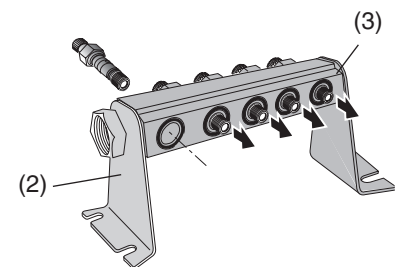

## OPTIONS

- Air operated 3/2 NAMUR subbase mounted version
- Equipment for use in potentially **explosive atmospheres** caused by dusts or gases (ATEX Directive 2014/34/EU)  
**Classification** II 2GD IIC T85°C (T6) X, **GD** suffix - example: G551A105GD

### DIMENSIONS (mm), WEIGHT (kg)

#### Series 551

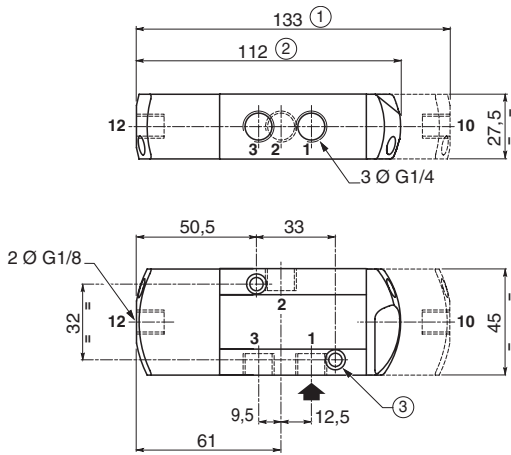

Ports for 3/2 NC	
1	= Pressure
2	= Outlet
3	= Exhaust
10	= Return
12	= Pilot

- ① air return
- ② spring return
- ③ 2 fixing holes : Ø 5,3 counterbore : Ø 9, depth 5

series	weight	
	monostable	bistable
551	0,28	0,36

#### Series 553

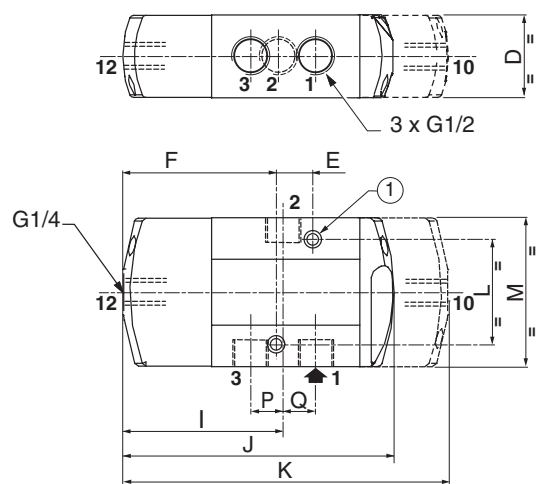

- ① 2 fixing holes Ø 6,5; counterbore : Ø 11, depth 6 mm dimension J: spring return dimension K: air return

series	D	E	F	I	J	K	L	M	P	Q	weight	
											monostable	bistable
553	40,2	16	78,5	62,7	134,5	162	51	72,3	12,1	19,4	0,80	1,06

### ASSEMBLY WITH SUPPLY RAIL

#### Installation without isolation valve

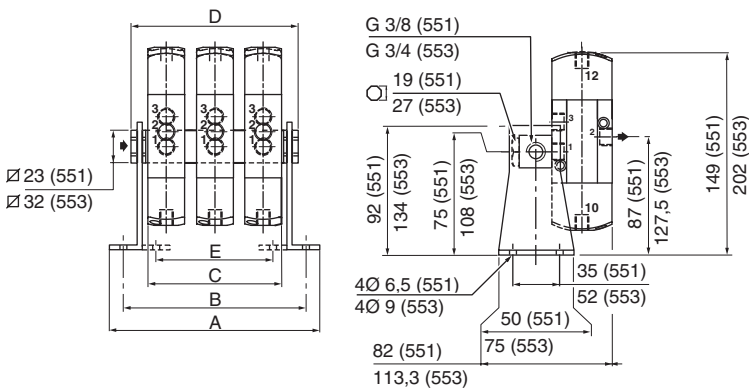

#### Installation with isolation valve

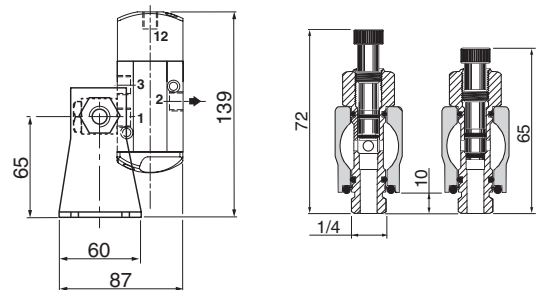

series	number of valves							
	2	3	4	5	6	7	8	
A	108	136	164	192	220	248	276	
B	92	120	148	176	204	232	260	
C	55	83	111	139	167	195	223	
D	78	106	134	162	190	218	246	
E	42	70	98	126	154	182	210	
weight								
monostable	0,9	1,2	1,5	1,9	2,2	2,5	2,8	
bistable	1	1,4	1,9	2,3	2,7	3,1	3,5	

series	number of valves							
	2	3	4	5	6	7	8	
A	136	177	218	259	300	341	382	
B	116	157	198	239	280	321	362	
C	81	122	163	204	245	286	327	
D	117	158	199	240	281	322	363	
E	-	-	-	-	-	-	-	
weight								
monostable	2,3	3,0	3,8	4,7	5,5	6,3	7,2	
bistable	2,5	3,5	4,6	5,7	6,7	7,7	8,7	

This mounting arrangement allows valves to be mounted in any of 4 positions.

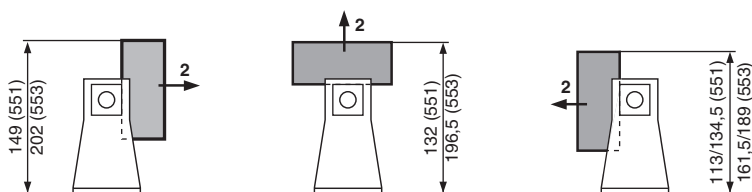

Not possible with supply rail and isolation valves

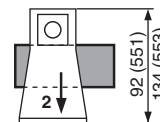

Only with supply rail with isolation valves (Series 551)

