

Linear sets with super linear bushings **A** or **B**

Linear sets, R1065 Closed

Linear sets, R1066 Adjustable

Design

- Precision housing (cast iron/steel)
- Super linear bushing with or without misalignment compensation
- Integrated wiper seals

Closed



Shaft Ø d (mm)	Material number		Weight (kg)
	Super linear bushing A Integrated wiper seals LSG-A- ... -DD	Super linear bushing B Integrated wiper seals LSG-B- ... -DD	
12	R1065 612 40	R1065 812 40	0.15
16	R1065 616 40	R1065 816 40	0.24
20	R1065 620 40	R1065 820 40	0.42
25	R1065 625 40	R1065 825 40	0.83
30	R1065 630 40	R1065 830 40	1.22
40	R1065 640 40	R1065 840 40	2.29
50	R1065 650 40	R1065 850 40	3.23

Adjustable



Shaft Ø d (mm)	Material number		Weight (kg)
	Super linear bushing A Integrated wiper seals LSGE-A- ... -DD	Super linear bushing B Integrated wiper seals LSGE-B- ... -DD	
12	R1066 612 40	R1066 812 40	0.15
16	R1066 616 40	R1066 816 40	0.24
20	R1066 620 40	R1066 820 40	0.41
25	R1066 625 40	R1066 825 40	0.79
30	R1066 630 40	R1066 830 40	1.19
40	R1066 640 40	R1066 840 40	2.26
50	R1066 650 40	R1066 850 40	3.15

Explanation of sample short product name

LS	G	E	A	20	DD
Linear set	Cast iron	Adjustable	Super A	Ø 20	Two seals

See page 39 for more information on short product names.

Dimensions

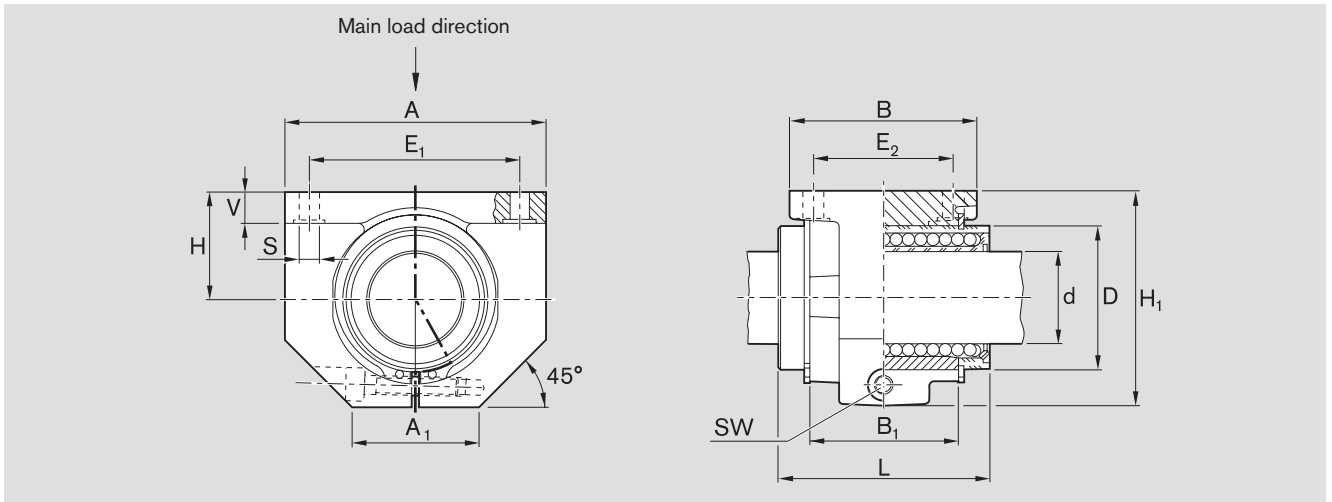

Dimensions (mm)

Ø d	D	H	H ₁ ¹⁾	L	A ¹⁾	A ₁ ¹⁾	B ¹⁾	B ₁	E ₁	E ₂	S	V ¹⁾	SW
12	22	18	35	32	42	21	32	20	32±0.15	23±0.15	4.5	5.5	2.5
16	26	22	42	36	50	26	35	22	40±0.15	26±0.15	4.5	6.5	3.0
20	32	25	50	45	60	28	42	28	45±0.15	32±0.15	4.5	8.0	3.0
25	40	30	60	58	74	38	54	40	60±0.15	40±0.15	5.5	9.0	5.0
30	47	35	70	68	84	41	60	48	68±0.20	45±0.20	6.6	10.0	5.0
40	62	45	90	80	108	51	78	56	86±0.20	58±0.20	9.0	12.0	6.0
50	75	50	105	100	130	57	70	72	108±0.20	50±0.20	9.0	14.0	8.0

Shaft Ø d (mm)	Radial clearance (µm)		Tolerance for H ²⁾ (µm)	Load ratings ³⁾ (N)	
	R1065 h6 shaft	R1066		dyn. C	stat. C ₀
12	+38	Comes clamped to h5 shaft (lower limit) and set to zero clearance	+8	1,020	490
	+10		-16		
16	+38		+8	1,500	830
	+10		-16		
20	+43		+8	2,470	1,340
	+11		-16		
25	+43		+8	5,040	2,470
	+11		-16		
30	+43		+8	5,860	3,570
	+11		-16		
40	+50		+8	10,070	5,570
	+12		-16		
50	+50		+13	14,730	8,280
	+12		-21		

- 1) ISO 8062-3 - DCTG 9 tolerance.
- 2) Clamped (fastened) in relation to Ø d.
- 3) The load ratings apply for the main load direction.
If the load direction is not the main load direction, the load ratings must be multiplied by the following factors:

Ø d 12 and 16: f = 0.82, f₀ = 0.86

Ø d 20 to 50: f = 0.82, f₀ = 0.78

The dynamic load ratings are based on a total travel of 100,000 m.
When based on 50,000 m, the C values in the table are multiplied by 1.26.