

Stainless Steel 316 Fittings

New

RoHS

Compact and Light

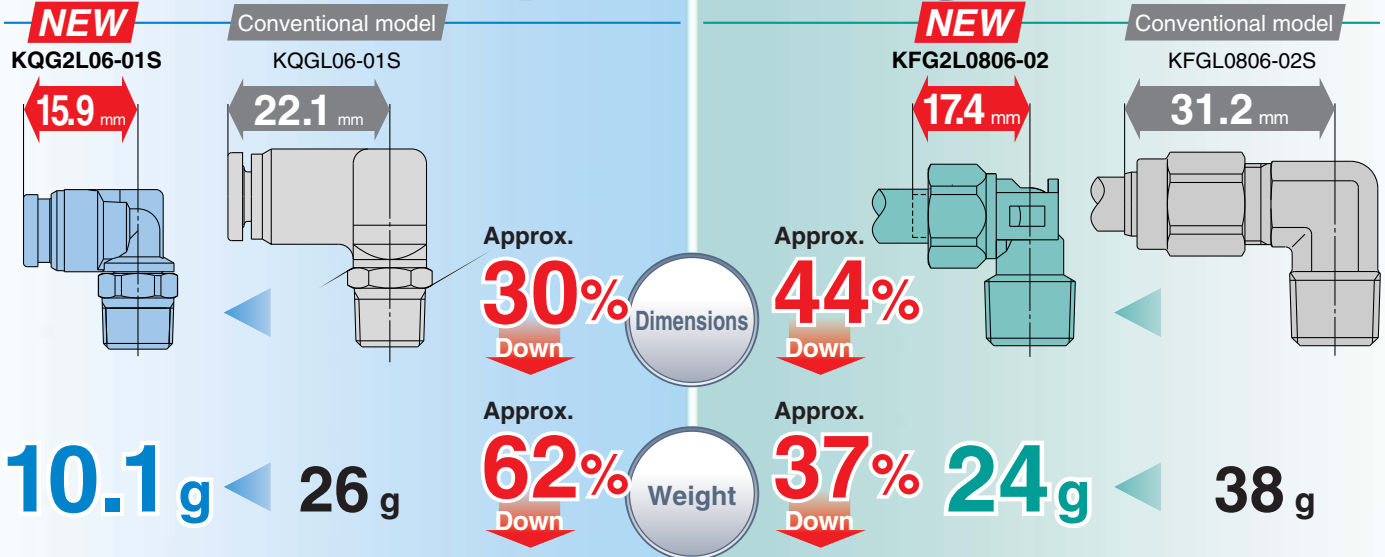

- More configuration variations
17 models < **9** models
- Tube size: $\varnothing 3.2$ and $\varnothing 16$ have been added.

- More configuration variations
9 models < **5** models
- Inch sizes have been added.

One-touch Fittings

Series KQG2



Seal parts: Special FKM

Material

Stainless steel 316

Insert Fittings

Series KFG2



Rubber material is not used.
(Except swivel elbow)

-5 to 150°C

Fluid temperature

-65 to 260°C
(Swivel elbow: -5 to 150°C)

Grease-free/Can be used with steam.

Metric size, Inch size **Applicable tube** Metric size, Inch size

M, R, Rc, UNF, NPT **Connection thread** R, Rc, NPT

Certified to meet current Food Sanitation Law standards.
(Component materials have met apparatus and container-packages standards.)



CAT.EUS50-33A-UK

Stainless Steel 316 One-touch Fittings *Series KQG2*

Compact and light

Dimensions: Approx. **30%** down

Weight: Approx. **62%** down

* Comparison with KQGL06-01S

More configuration variations

17 models < **9** models

More tube sizes added

Ø3.2 and **Ø16** have been added.

Material

Metal parts: **Stainless steel 316**

Seal parts: Special **FKM**

Applicable tube material

FEP • PFA • Nylon • Soft nylon
Polyurethane • Polyolefin

Fluid temperature: -5 to 150°C

Grease-free

Can be used with steam.

NEW

KQG2L06-01S

15.9 mm

Weight
10.1 g

Conventional model

KQGL06-01S

22.1 mm

Weight
26 g

All **Stainless steel 316**
except seal parts

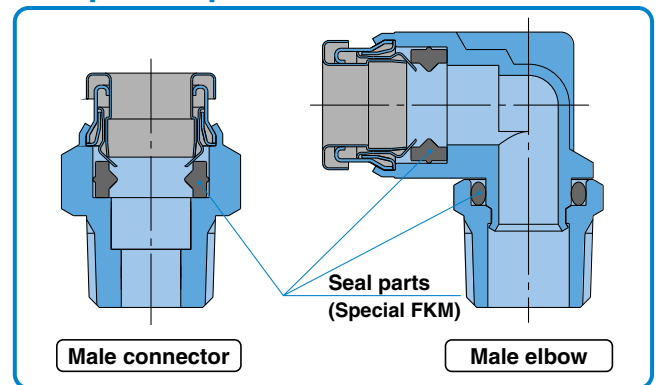

Applicable tube	Connection thread	Page
Metric size	M, R, Rc	P.1 to 7
Inch size	UNF, NPT	P.8 to 14



Certified to meet current
Food Sanitation Law standards.
(Component materials have
met apparatus and container-
packages standards.)

Stainless Steel 316 Insert Fittings *Series KFG2*

Compact and light

Dimensions: Approx. **44%** down

Weight: Approx. **37%** down

* Comparison with KFG0806-02S

More configuration variations

9 models < **5** models

Material: Stainless steel 316

Rubber material is not used.
(Except swivel elbow)

Fluid temperature

-65 to 260°C

(Swivel elbow: **-5 to 150°C**)

Applicable tube material

FEP • PFA • Modified PTFE

Nylon • Soft nylon • Polyolefin

Polyurethane* • Soft polyurethane*

Hard polyurethane*

Soft polyolefin*

Antistatic soft nylon* • Antistatic polyurethane*

Note) For tubes marked *, check the appropriate size. (Page 16, 21)

Grease-free

Can be used with steam.

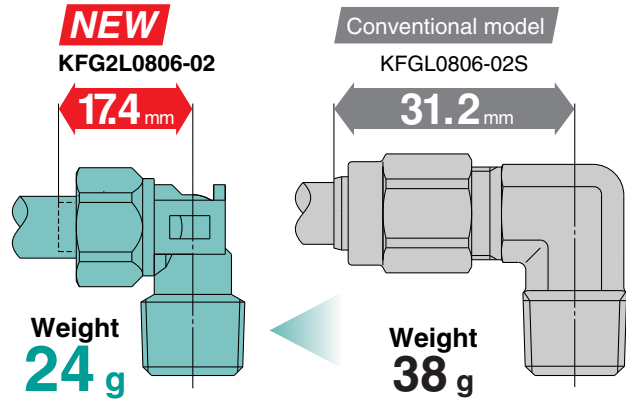

Sleeveless Sleeveless sealing structure makes replacement parts for maintenance unnecessary.

Superior tube mounting

Union nut

Light tightening torque
Comparison with conventional model

Approx. **60%** down
* Comparison with KFG□0806

Barb

Sealing performance and holding of tube are secured by back-up from the barb.

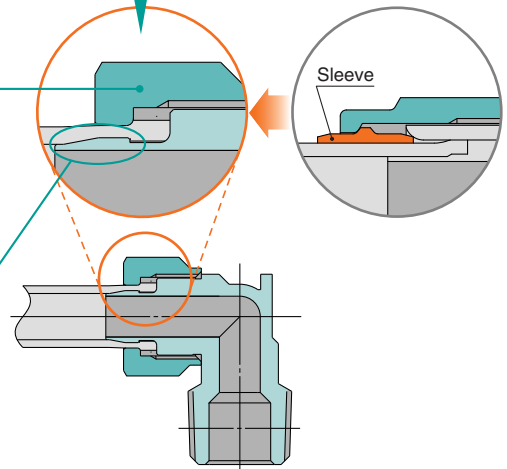

Applicable tube	Connection thread	Page
Metric size	R, Rc	P.16 to 20
Inch size	NPT	P.21 to 24

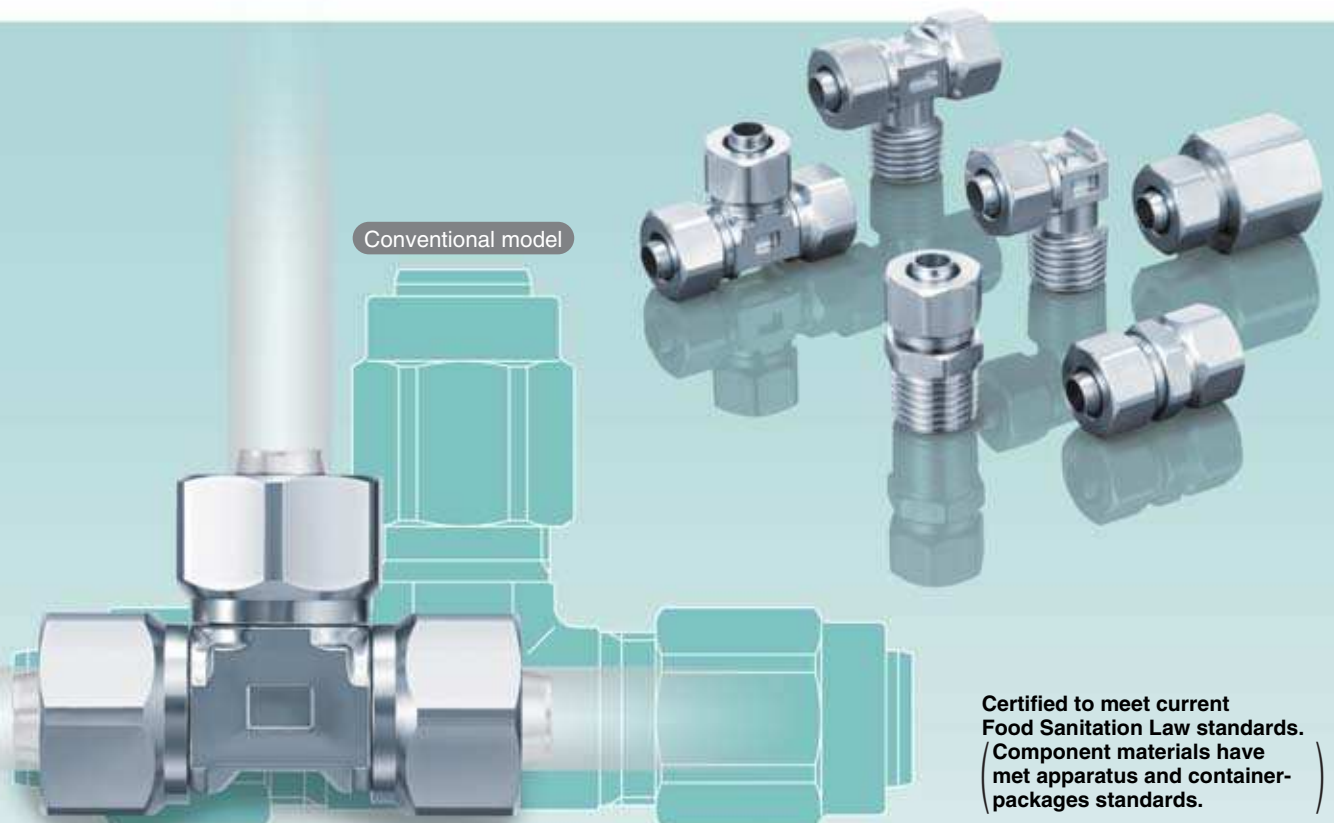

Certified to meet current Food Sanitation Law standards. (Component materials have met apparatus and container-packages standards.)

Stainless Steel 316 One-touch Fittings *Series KQG2*

Variations

Male Connector **KQG2H**



Metric P. 3
Inch P. 9

Bulkhead Union **KQG2E**



Metric P. 5
Inch P. 11

Different Diameter Union "Y" **KQG2U**



Metric P. 6
Inch P. 12

Hexagon Socket Head Male Connector **KQG2S**



Metric P. 3
Inch P. 9

Union Tee **KQG2T**



Metric P. 5
Inch P. 11

Bulkhead Connector **KQG2E**



Metric P. 6
Inch P. 12

Straight Union **KQG2H**



Metric P. 3
Inch P. 9

Union "Y" **KQG2U**



Metric P. 5
Inch P. 11

Extended Male Elbow **KQG2W**



Metric P. 7
Inch P. 12

Male Elbow **KQG2L**



Metric P. 4
Inch P. 10

Different Diameter Tee **KQG2T**



Metric P. 5
Inch P. 11

Female Connector **KQG2F**



Metric P. 7
Inch P. 13

Male Branch Tee **KQG2T**



Metric P. 4
Inch P. 10

Plug-in Reducer **KQG2R**



Metric P. 5
Inch P. 11

Plug **KQG2P**



Metric P. 7
Inch P. 13

Union Elbow **KQG2L**



Metric P. 4
Inch P. 10

Different Diameter Straight **KQG2H**



Metric P. 6
Inch P. 12

Stainless Steel 316 One-touch Fittings

Applicable Tube: Metric Size, Connection Thread: M, R, Rc

Series **KQG2**

RoHS



Applicable Tube

Tube material	FEP, PFA, Nylon, Soft nylon ^{Note 1)} , Polyurethane, Polyolefin
Tube O.D.	ø3.2, ø4, ø6, ø8, ø10, ø12, ø16

Specifications

Fluid	Air, Water, Steam ^{Note 2)}
Operating pressure range ^{Note 3)}	-100 kPa to 1 MPa ^{Note 4)}
Proof pressure	3.0 MPa
Ambient and fluid temperature ^{Note 5)}	-5 to 150°C (No freezing) ^{Note 4)}
Lubricant	Grease-free specification
Seal on the threads	With sealant

Note 1) For soft nylon tube, water cannot be used.

Note 2) Consult with SMC regarding applicable tube separately.

Note 3) Avoid using in a vacuum holding application such as a leak tester, since there is leakage.

Note 4) Check the operating pressure range and operating temperature range of the tube.

Note 5) It is recommended that you use the inner sleeve in the following conditions (Except ø3.2):

- When using in an environment where the fluid temperature changes drastically.
- When using at a high temperature.

* Temperature Condition of Mounting the Inner Sleeve

Tube	Temperature
FEP tube/TH series	80°C or more
PFA tube/TL series	120°C or more

Spare Parts

Description	Tube O.D.	Part no.	Material
Gasket	—	M-5G3	Stainless steel 316, Special FKM
Bulkhead nut	ø3.2, ø4	KQG223-P01	Stainless steel 316
	ø6	KQG206-P01	
	ø8	KQG208-P01	
	ø10	KQG210-P01	
	ø12	KQG212-P01	
	ø16	KQG216-P01	

Cross Reference Table of the Inner Sleeve

Tube O.D.	Tube material			Applicable inner sleeve	
	TUS (Soft polyurethane)	TH/THI (FEP)	TL/TIL (PFA)	Part no.	Length
ø4	—	TH0402	—	TJG-0402	18
	TUS0425	TH0425	—	TJG-0425	18
	—	—	TL0403	TJG-0403	18
ø6	TUS0604	TH0604	TL0604	TJG-0604	19
	TUS0805	—	—	TJG-0805	20.5
ø8	—	TH0806	TL0806	TJG-0806	20.5
	TUS1065	—	—	TJG-1065	23
ø10	—	TH1075	—	TJG-1075	23
	—	TH1008	TL1008	TJG-1008	23
	TUS1208	—	—	TJG-1208	24
ø12	—	TH1209	—	TJG-1209	24
	—	TH1210	TL1210	TJG-1210	24
	—	—	—	—	—

* Stainless steel 316 is used for the TJG series.

Construction

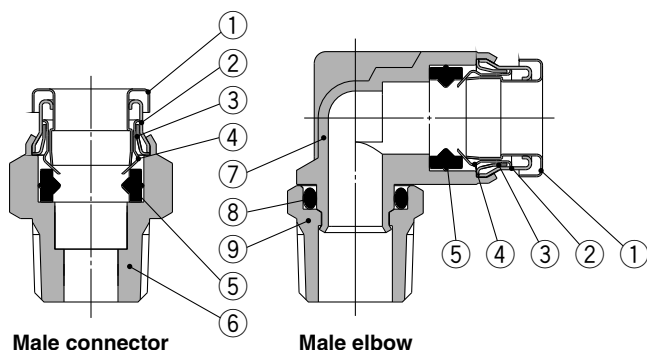

Component Parts

No.	Description	Material
1	Release button	Stainless steel 316
2	Guide 1	Stainless steel 316
3	Guide 2	Stainless steel 316
4	Chuck	Stainless steel 316
5	Seal	Special FKM (Fluoro coated)
6	Male connector body	Stainless steel 316
7	Male elbow body	Stainless steel 316
8	O-ring	Special FKM (Fluoro coated)
9	Stud	Stainless steel 316

Series KQG2

Applicable Tube: Metric Size, Connection Thread: M, R, Rc

Dimensions

Male Connector: KQG2H



Applicable tube O.D. (mm)	Connection thread R, M	Model	H (Width across flat)	Note 1) ϕD	L	A*	M	Note 2) Effective area (mm ²)	Weight (g)
$\phi 3.2$	M5	KQG2H23-M5	8	8	16.5	13.5	12	3	3.3
	1/8	KQG2H23-01S	10		15.4	12.3		3.4	5.7
	1/4	KQG2H23-02S	14		21	16.3		16.9	
$\phi 4$	M5	KQG2H04-M5	10	8.7	17.1	14.1	12.6	4	5
	1/8	KQG2H04-01S	10		15.3	12.2		4.7	
	1/4	KQG2H04-02S	14		20.9	16.2		15.8	
$\phi 6$	M5	KQG2H06-M5	12	11.1	19.1	16.1	13.6	4	7.7
	1/8	KQG2H06-01S	12		18.1	15		7	
	1/4	KQG2H06-02S	14		20.8	16.1		13.1	14.5
	3/8	KQG2H06-03S	17		23	17.9		27.3	
$\phi 8$	1/8	KQG2H08-01S	14	13.4	24.5	21.4	16.1	26.1	12.8
	1/4	KQG2H08-02S	14		22.3	17.6		12.9	
	3/8	KQG2H08-03S	17		23.7	18.6		24.7	
$\phi 10$	1/8	KQG2H10-01S	17	16.4	25.5	22.4	17	26.1	18.9
	1/4	KQG2H10-02S	17		27.9	23.2		21.6	
	3/8	KQG2H10-03S	17		23	17.9		41.5	20.6
	1/2	KQG2H10-04S	22		28.6	22.2		51.1	
$\phi 12$	1/4	KQG2H12-02S	19	18.5	30.5	25.8	18.6	58.3	27.4
	3/8	KQG2H12-03S	19		24.7	19.6		20.5	
	1/2	KQG2H12-04S	22		28.7	22.3		44.6	
$\phi 16$	3/8	KQG2H16-03S	24	24.6	33.6	28.5	20.8	81	46
	1/2	KQG2H16-04S	24		29.5	23.1		113	37.4

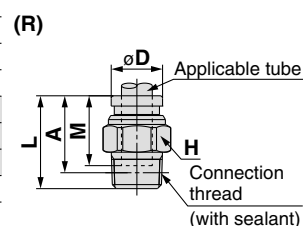
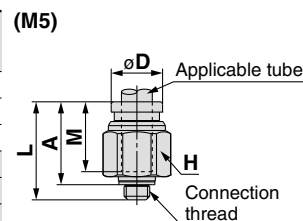

* Reference dimensions after installation of R thread
 Note 1) ϕD is maximum diameter.
 Note 2) Value of FEP tube.
 Value of nylon tube for $\phi 16$ only.

Hexagon Socket Head Male Connector: KQG2S



Applicable tube O.D. (mm)	Connection thread R, M	Model	H (Width across flat)	Note 1) ϕD	L	A*	M	Note 2) Effective area (mm ²)	Weight (g)
$\phi 3.2$	M5	KQG2S23-M5	2	9	16.5	13.5	12	3	3.8
$\phi 4$	M5	KQG2S04-M5	2	9	17.1	14.1	12.6	4	3.7
	1/8	KQG2S04-01S	3	10	19.6	16.5		4.1	7.6
$\phi 6$	M5vv	KQG2S06-M5	2	12	19.6	16.6	13.6	4	7.4
	1/8	KQG2S06-01S	4		20.6	17.5		10	8.7
	1/4	KQG2S06-02S	4		14	15.9		10.7	14
$\phi 8$	1/8	KQG2S08-01S	5	14	24.7	21.6	16.1	17.2	12.3
	1/4	KQG2S08-02S	6		22.9	18.2		12.8	
	3/8	KQG2S08-03S	6		17	23.1		18	22.8
$\phi 10$	1/8	KQG2S10-01S	5	17	25.6	22.5	17	17.2	17.7
	1/4	KQG2S10-02S	8		27.5	22.8		19.1	
	3/8	KQG2S10-03S	8		24	18.9		39	20.9
	1/2	KQG2S10-04S	22		17.6	37.2			
$\phi 12$	1/4	KQG2S12-02S	8	19	30.6	25.9	18.6	46	24.8
	3/8	KQG2S12-03S	10		24.9	19.8		19.3	
	1/2	KQG2S12-04S	10		22	18.5		60	33.6
$\phi 16$	3/8	KQG2S16-03S	10	24.6	33.2	28.1	20.8	81	41.6
	1/2	KQG2S16-04S	12		29.4	23		113	38.4

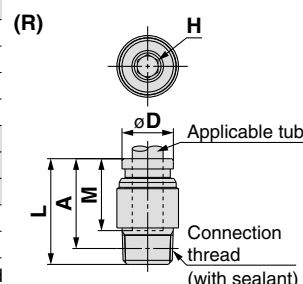
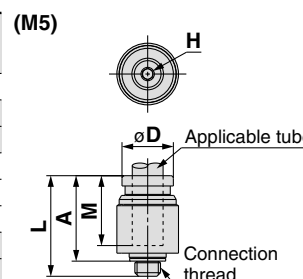

* Reference dimensions after installation of R thread
 Note 1) ϕD is maximum diameter.
 Note 2) Value of FEP tube.
 Value of nylon tube for $\phi 16$ only.

Straight Union: KQG2H



Applicable tube O.D. (mm)	Model	ϕD Note 1)	L	M	Note 2) Effective area (mm ²)	Weight (g)
$\phi 3.2$	KQG2H23-00	9	25	12	3.4	6.5
$\phi 4$	KQG2H04-00	9	26.2	12.6	5.6	6.5
$\phi 6$	KQG2H06-00	12	28.2	13.6	13.1	11.5
$\phi 8$	KQG2H08-00	14	33.2	16.1	26.1	16.6
$\phi 10$	KQG2H10-00	17	35	17	41.5	26
$\phi 12$	KQG2H12-00	19	38.2	18.6	58.3	32.2
$\phi 16$	KQG2H16-00	24.6	42.6	20.8	113	53.7

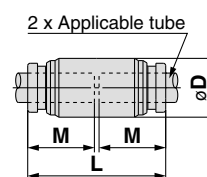

Note 1) ϕD is maximum diameter.
 Note 2) Value of FEP tube.
 Value of nylon tube for $\phi 16$ only.

Dimensions

Male Elbow: KQG2L

Applicable tube O.D. (mm)	Connection thread R, M	Model	H (Width across flat)	Note 1) ϕD	L1	L2	A*	M	Note 2) Effective area (mm ²)	Weight (g)
$\phi 3.2$	M5	KQG2L23-M5	8	8.3	13.1	14.8	16	12	2.6	6.3
	1/8	KQG2L23-01S	10		13.6	14.9	15.9		3	7.6
	1/4	KQG2L23-02S	14		18.7	18.1	16			
$\phi 4$	M5	KQG2L04-M5	8	9.1	13.7	15.2	16.8	12.6	3.5	6.9
	1/8	KQG2L04-01S	10		14.4	15.3	16.7		4.2	8.5
	1/4	KQG2L04-02S	14		19.1	18.9	16.8			
$\phi 6$	M5	KQG2L06-M5	8	11.4	14.7	16.3	19	13.6	3.5	8.8
	1/8	KQG2L06-01S	10		16.4	10.1				
	1/4	KQG2L06-02S	14		15.9	20.2	21.2		11.4	18.4
	3/8	KQG2L06-03S	17		21.6	22.2	29.9			
$\phi 8$	1/8	KQG2L08-01S	12	13.7	18.6	18.3	22	16.1	21.6	14.6
	1/4	KQG2L08-02S	14		19.1	21.5	23.6		20.3	
	3/8	KQG2L08-03S	17		22.9	24.6	31.6			
$\phi 10$	1/8	KQG2L10-01S	12	16.6	20	19.7	24.9	17	21.6	20.2
	1/4	KQG2L10-02S	14		22.9	26.5	23.3			
	3/8	KQG2L10-03S	17		21	24.3	27.5		35.2	33.6
	1/2	KQG2L10-04S	22		28.5	30.4	60.1			
$\phi 12$	1/4	KQG2L12-02S	14	18.7	22.6	24	28.6	18.6	50.2	27.1
	3/8	KQG2L12-03S	17		23.6	25.3	29.5		33.7	
	1/2	KQG2L12-04S	22		29.5	32.4	58.7			
$\phi 16$	3/8	KQG2L16-03S	19	24.6	26.3	28	34.5	20.8	71	46.3
	1/2	KQG2L16-04S	22		27.3	31.8	37		100	61.3

* Reference dimensions after installation of R thread
Note 1) ϕD is maximum diameter.

Note 2) Value of FEP tube.
Value of nylon tube for $\phi 16$ only.

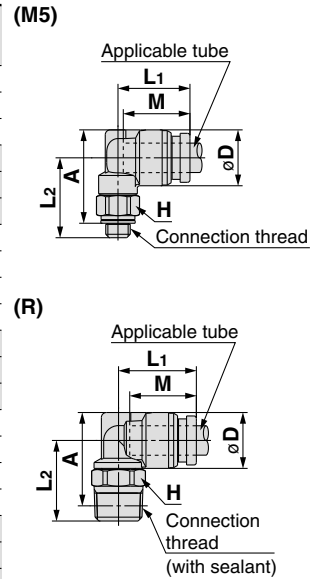

Male Branch Tee: KQG2T

Applicable tube O.D. (mm)	Connection thread R, M	Model	H (Width across flat)	Note 1) ϕD	L1	L2	A*	M	Note 2) Effective area (mm ²)	Weight (g)
$\phi 3.2$	M5	KQG2T23-M5	8	8.3	13.1	14.8	16	12	3.2	8.1
	1/8	KQG2T23-01S	10		13.6	14.9	15.9		3.4	9.4
	1/4	KQG2T23-02S	14		18.7	18.1	17.7			
$\phi 4$	M5	KQG2T04-M5	8	9.1	13.7	15.2	16.8	12.6	4.5	9
	1/8	KQG2T04-01S	10		14.4	15.3	16.7		6	10.4
	1/4	KQG2T04-02S	14		19.1	18.9	18.8			
$\phi 6$	M5	KQG2T06-M5	8	11.4	14.7	16.3	19	13.6	4.5	11.9
	1/8	KQG2T06-01S	10		16.4	13.4				
	1/4	KQG2T06-02S	14		15.9	20.2	21.2		13.9	21.8
	3/8	KQG2T06-03S	17		21.6	22.2	33.3			
$\phi 8$	1/8	KQG2T08-01S	12	13.7	18.6	18.3	22	16.1	26.3	20
	1/4	KQG2T08-02S	14		19.1	21.5	23.6		25.5	
	3/8	KQG2T08-03S	17		22.9	24.6	36.8			
$\phi 10$	1/8	KQG2T10-01S	12	16.6	20	19.7	24.9	17	40.8	28.4
	1/4	KQG2T10-02S	14		22.9	26.5	31.1			
	3/8	KQG2T10-03S	17		21	24.3	27.5		41.4	
	1/2	KQG2T10-04S	22		28.5	30.4	68			
$\phi 12$	1/4	KQG2T12-02S	14	18.7	22.6	24	28.6	18.6	57.2	37.8
	3/8	KQG2T12-03S	17		23.6	25.3	29.5		39.3	
	1/2	KQG2T12-04S	22		29.5	32.4	68.8			
$\phi 16$	3/8	KQG2T16-03S	19	24.6	26.3	28	34.5	20.8	71	63.7
	1/2	KQG2T16-04S	22		27.3	31.8	37		100	77.6

* Reference dimensions after installation of R thread
Note 1) ϕD is maximum diameter.

Note 2) Value of FEP tube.
Value of nylon tube for $\phi 16$ only.

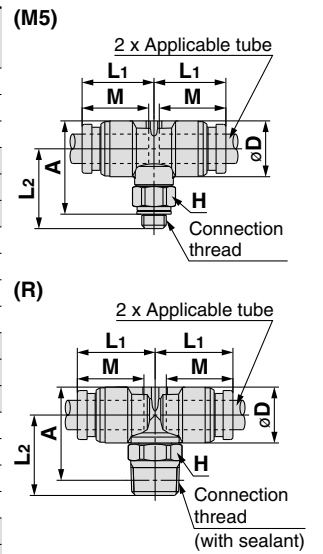

Union Elbow: KQG2L

Applicable tube O.D. (mm)	Model	Note 1) ϕD	L	A	Q	M	ϕN	ϕO	Note 2) Effective area (mm ²)	Weight (g)
$\phi 3.2$	KQG2L23-00	8.3	13.6	19.3	2.9	12	3.2	5.6	3	6.3
$\phi 4$	KQG2L04-00	9.1	14.6	20.5	3.1	12.6	3.2	5.6	4.2	7.4
$\phi 6$	KQG2L06-00	11.4	16.6	23	3.6	13.6	3.2	5.6	11.4	11
$\phi 8$	KQG2L08-00	13.7	20.1	29.1	5	16.1	4.2	8	21.6	20.2
$\phi 10$	KQG2L10-00	16.6	22	31.7	5.7	17	4.2	8	35.2	29.6
$\phi 12$	KQG2L12-00	18.7	24.6	35	6.4	18.6	4.2	8	50.2	37.1
$\phi 16$	KQG2L16-00	24.6	28.8	40.5	7.7	20.8	4.2	8	100	59.7

Note 1) ϕD is maximum diameter.

Note 2) Value of FEP tube.
Value of nylon tube for $\phi 16$ only.

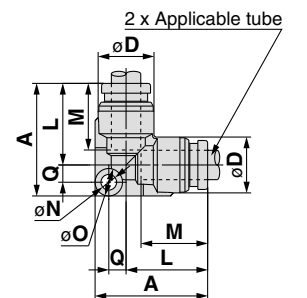

Series KQG2

Applicable Tube: Metric Size, Connection Thread: M, R, Rc

Dimensions

Bulkhead Union: KQG2E



Applicable tube O.D. (mm)	Model	T (M)	H (Width across flat)	L	Mounting hole	M	Note 2) Effective area (mm ²)	Weight (g)
ø3.2	KQG2E23-00	M10 x 1	12	32.2	11	12	3.4	14
ø4	KQG2E04-00	M10 x 1	12	32.4	11	12.6	5.6	14
ø6	KQG2E06-00	M14 x 1	17	33.6	15	13.6	13.1	25.8
ø8	KQG2E08-00	M15 x 1	19	36.4	16	16.1	26.1	30.4
ø10	KQG2E10-00	M18 x 1	21	37.2	19	17	41.5	40.3
ø12	KQG2E12-00	M20 x 1	24	39.2	21	18.6	58.3	49.9
ø16	KQG2E16-00	M27 x 1	30	42.6	28	20.8	113	87.3

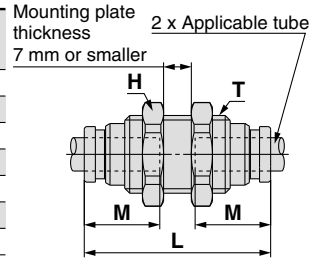

Note) Value of FEP tube.
Value of nylon tube for ø16 only.

Union Tee: KQG2T



Applicable tube O.D. (mm)	Model	Note 1) øD	L	A	Q	M	øN	øO	Note 2) Effective area (mm ²)	Weight (g)
ø3.2	KQG2T23-00	8.3	13.6	20.5	4.1	12	3.2	5.6	3.4	7.9
ø4	KQG2T04-00	9.1	14.6	21.8	4.4	12.6	3.2	5.6	6.4	9.5
ø6	KQG2T06-00	11.4	16.6	24.6	5.2	13.6	3.2	5.6	13.4	14.2
ø8	KQG2T08-00	13.7	20.1	31.1	7	16.1	4.2	8	25.6	24.4
ø10	KQG2T10-00	16.6	22	34	8	17	4.2	8	40	36.8
ø12	KQG2T12-00	18.7	24.6	37.7	9.1	18.6	4.2	8	57.4	46.9
ø16	KQG2T16-00	24.6	28.8	43.4	10.6	20.8	4.2	8	100	75.5

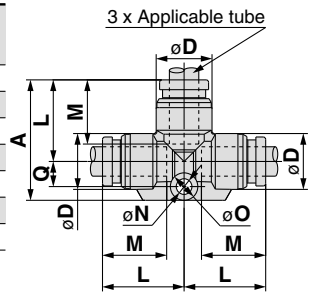

Note 1) øD is maximum diameter.
Note 2) Value of FEP tube.
Value of nylon tube for ø16 only.

Union "Y": KQG2U



Applicable tube O.D. (mm)	Model	Note 1) øD	W	L ₁	L ₂	P	M	øN	øO	Note 2) Effective area (mm ²)	Weight (g)
ø3.2	KQG2U23-00	8.3	16.4	29	11	8.1	12	3.2	5.6	3.4	9.2
ø4	KQG2U04-00	9.1	18.2	30.4	11.3	9.1	12.6	3.2	5.6	4.2	11.1
ø6	KQG2U06-00	11.4	22.9	34.9	12.2	11.5	13.6	3.2	5.6	13.4	18.8
ø8	KQG2U08-00	13.7	28.3	40.1	14.1	14.6	16.1	4.2	8	25.6	29.7
ø10	KQG2U10-00	16.6	34.2	44	14.4	17.6	17	4.2	8	40	47.4
ø12	KQG2U12-00	18.7	38.5	48.4	15.8	19.8	18.6	4.2	8	57.4	62.1
ø16	KQG2U16-00	24.6	49.3	56.6	17.3	26	20.8	4.2	8	113	110.2

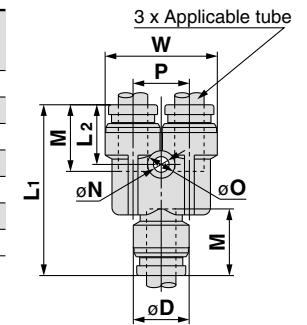

Note 1) øD is maximum diameter.
Note 2) Value of FEP tube.
Value of nylon tube for ø16 only.

Different Diameter Tee: KQG2T



Applicable tube O.D. (mm)		Model	Note 1) øD ₁	Note 1) øD ₂	L ₁	L ₂	L ₃	Q	M ₁	M ₂	øN	øO	Note 2) Effective area (mm ²)	Weight (g)
a	b													
ø3.2	ø4	KQG2T23-04	9.1	8.3	14.2	14.1	21.1	4.1	12.6	12	3.2	5.6	3.8	8.5
ø4	ø6	KQG2T04-06	11.4	9.1	15.6	15.7	22.8	4.4	13.6	12.6	3.2	5.6	7.1	11.5
ø6	ø8	KQG2T06-08	13.7	11.4	19.1	17.7	29.5	6.4	16.1	13.6	4.2	8	16.4	20
ø8	ø10	KQG2T08-10	16.6	13.7	21	21.2	32.1	7.1	17	16.1	4.2	8	36	29.8
ø10	ø12	KQG2T10-12	18.7	16.6	23.6	23.1	35.7	8.1	18.6	17	4.2	8	56	41.3
ø12	ø16	KQG2T12-16	24.6	18.7	26.8	26.7	39.9	9.1	20.8	18.6	4.2	8	108.5	58

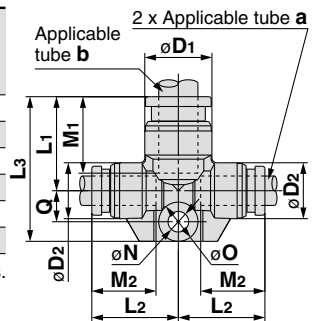

Note 1) øD₁, øD₂ are maximum diameters.
Note 2) Value of FEP tube.

Plug-in Reducer: KQG2R



Applicable tube O.D. (mm)	Applicable fitting size ød	Model	Note 1) øD	L	A	M	Note 2) Effective area (mm ²)	Weight (g)
ø3.2	ø4	KQG2R23-04	9	32.9	20.3	12	3.4	4.7
ø4	ø6	KQG2R04-06	9	34.4	20.8	12.6	5.6	6.7
ø6	ø8	KQG2R06-08	12	38.4	22.3	13.6	13.1	12.1
ø8	ø10	KQG2R08-10	14	41.9	24.9	16.1	26.1	18.3
ø10	ø12	KQG2R10-12	17	44.8	26.2	17	41.5	26.5
ø12	ø16	KQG2R12-16	19	42.9	22.1	18.6	58.3	35.4

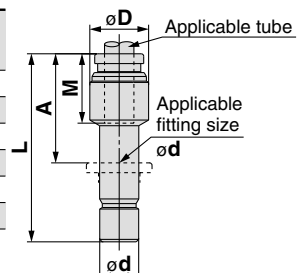

Note 1) øD is maximum diameter.
Note 2) Value of FEP tube.

Dimensions

Different Diameter Straight: KQG2H



Applicable tube O.D. (mm)		Model	Note 1) øD	L	M1	M2	Note 2) Effective area (mm ²)	Weight (g)
a	b							
ø3.2	ø4	KQG2H23-04	9	25.6	12	12.6	3.4	6.5
ø4	ø6	KQG2H04-06	12	27.2	12.6	13.6	5.6	11.6
ø6	ø8	KQG2H06-08	14	30.7	13.6	16.1	13.1	16.3
ø8	ø10	KQG2H08-10	17	34.1	16.1	17	26.1	26
ø10	ø12	KQG2H10-12	19	36.6	17	18.6	41.5	33.3
ø12	ø16	KQG2H12-16	24.6	40.4	18.6	20.8	58.3	54.7

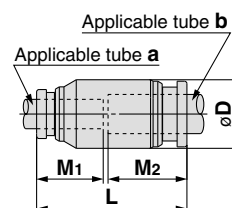

Note 1) øD is maximum diameter.
Note 2) Value of FEP tube.

Different Diameter Union "Y": KQG2U



Applicable tube O.D. (mm)		Model	Note 1) øD	L1	L2	P	W	M1	M2	øN	øO	Note 2) Effective area (mm ²)	Weight (g)
a	b												
ø3.2	ø4	KQG2U23-04	9.1	27	10.8	8.1	16.4	12	12.6	3.2	5.6	3.2	8.5
ø4	ø6	KQG2U04-06	11.4	29.3	11.2	9.1	18.2	12.6	13.6	3.2	5.6	4.2	11.9
ø6	ø8	KQG2U06-08	13.7	33.7	12.2	11.5	22.9	13.6	16.1	4.2	8	13.4	19.3
ø8	ø10	KQG2U08-10	16.6	38.3	13.8	14.6	28.3	16.1	17	4.2	8	25.6	31.6
ø10	ø12	KQG2U10-12	18.7	43	14	17.6	34.2	17	18.6	4.2	8	40	47.6
ø12	ø16	KQG2U12-16	24.6	47.4	15.6	19.8	38.5	18.6	20.8	4.2	8	57.4	67.6

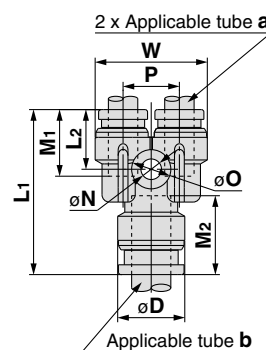

Note 1) øD is maximum diameter.
Note 2) Value of FEP tube.

Bulkhead Connector: KQG2E



Applicable tube O.D. (mm)	Connection thread Rc	Model	T (M)	Width across flat		L1	L2	Mounting hole	M	Note) Effective area (mm ²)	Weight (g)	
				H1	H2							
ø3.2	1/4	KQG2E23-02	M10 x 1	17	12	31	14.8	11	12	3.4	26.1	
	1/8											
ø4	1/4	KQG2E04-01	M10 x 1	14	12	25.8	9.7	11	12.6	5.6	16	
	1/8											
ø6	1/8	KQG2E06-01	M14 x 1	17	17	24.2	7	15	13.6	13.1	24.4	
	1/4											
	3/8											
ø8	1/8	KQG2E08-01	M15 x 1	17	19	26.3	8.1	16	16.1	26.1	28	
	1/4											
	3/8											
ø10	1/4	KQG2E10-02	M18 x 1	19	21	31.6	13	19	17	41.5	42.8	
	3/8											
	1/2											
ø12	3/8	KQG2E12-03	M20 x 1	21	24	34	14.4	21	18.6	58.3	50.3	
	1/2											
ø16	3/8	KQG2E16-03	M27 x 1	29	30	35.3	13.3	28	20.8	96	107.8	
	1/2											
											113	114.6

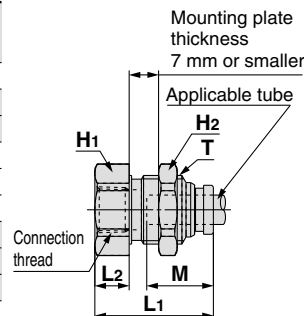

Note) Value of FEP tube.
Value of nylon tube for ø16 only.

Series KQG2

Applicable Tube: Metric Size, Connection Thread: M, R, Rc

Dimensions

Extended Male Elbow: KQG2W



Applicable tube O.D. (mm)	Connection thread R, M	Model	H (Width across flat)	Note 1) ϕD	L1	L2	A*	M	Note 2) Effective area (mm ²)	Weight (g)
$\phi 3.2$	M5	KQG2W23-M5	8	8.3	13.1	31.2	32.4	12	2.8	13
	1/8	KQG2W23-01S	10		13.6	31.3	32.3			14.7
	1/4	KQG2W23-02S	14		35.1	34.5	33.1			
$\phi 4$	M5	KQG2W04-M5	8	9.1	13.7	31.6	33.2	12.6	3	13.6
	1/8	KQG2W04-01S	10		14.4	31.7	33.1			15.6
	1/4	KQG2W04-02S	14		35.5	35.3	33.9			
$\phi 6$	M5	KQG2W06-M5	8	11.4	14.7	32.7	35.4	13.6	10.9	15.5
	1/8	KQG2W06-01S	10		32.8	37.6	17.2			
	1/4	KQG2W06-02S	14		36.6	37.6	35.5			
	3/8	KQG2W06-03S	17		38	38.6	57.4			
$\phi 8$	1/8	KQG2W08-01S	12	13.7	18.6	37	40.7	16.1	20.5	28
	1/4	KQG2W08-02S	14		19.1	40.2	42.3			37.7
	3/8	KQG2W08-03S	17		41.6	43.3	60.9			
$\phi 10$	1/4	KQG2W10-02S	14	16.6	21	46.6	50.2	17	33.5	40.7
	3/8	KQG2W10-03S	17		45.9	49.1	61.9			
	1/2	KQG2W10-04S	22		50.1	52	117.3			
$\phi 12$	1/4	KQG2W12-02S	14	18.7	22.6	47.7	52.3	18.6	47.7	44.6
	3/8	KQG2W12-03S	17		23.6	49	53.2			56.3
	1/2	KQG2W12-04S	22		53.2	56.1	112.9			
$\phi 16$	3/8	KQG2W16-03S	19	24.6	26.3	57.6	64.1	20.8	71	86.6
	1/2	KQG2W16-04S	22		27.3	61.4	66.6			100

* Reference dimensions after installation of R thread
 Note 1) ϕD is maximum diameter.
 Note 2) Value of FEP tube.
 Value of nylon tube for $\phi 16$ only.

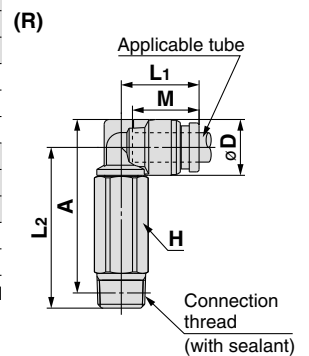
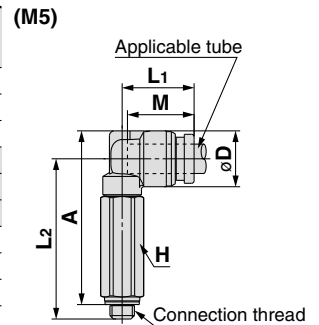

Female Connector: KQG2F



Applicable tube O.D. (mm)	Connection thread Rc	Model	H (Width across flat)	Note 1) ϕD	L1	L2	M	Note 2) Effective area (mm ²)	Weight (g)
$\phi 3.2$	1/8	KQG2F23-01	12	8	23.3	9.8	12	3.4	8.9
	1/8	KQG2F04-01	12		23.7	9.8			9.2
$\phi 4$	1/4	KQG2F04-02	17	8.7	28.7	13.2	12.6	5.6	21.6
	1/8	KQG2F06-01	12		24.2	10			10.5
$\phi 6$	1/4	KQG2F06-02	17	11.1	29.2	13.4	13.6	13.1	23.1
	3/8	KQG2F06-03	19		30.6	14.2			24.5
	1/8	KQG2F08-01	14		26.3	9.6			16.3
$\phi 8$	1/4	KQG2F08-02	17	13.4	31.3	13.7	16.1	26.1	25.5
	3/8	KQG2F08-03	19		32.7	14.4			27
	1/4	KQG2F10-02	17		31.6	13.9			28.8
$\phi 10$	3/8	KQG2F10-03	19	16.4	33	14.7	17	41.5	30.4
	1/4	KQG2F12-02	17		32.6	13.3			37.5
$\phi 12$	3/8	KQG2F12-03	19	18.5	34	14.7	18.6	58.3	32.3
	1/2	KQG2F12-04	24		39.3	18.4			50.2
	3/8	KQG2F16-03	19		35.3	13.5			59.7
$\phi 16$	1/2	KQG2F16-04	24	24.6	40.6	18.8	20.8	113	57

Note 1) ϕD is maximum diameter.
 Note 2) Value of FEP tube.
 Value of nylon tube for $\phi 16$ only.

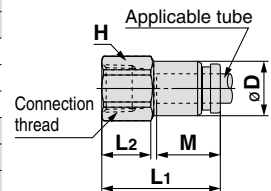

Plug: KQG2P



Applicable fitting size ϕd	Model	ϕD	L	A	Weight (g)
$\phi 3.2$	KQG2P-23	5	28.9	16.9	2.7
$\phi 4$	KQG2P-04	6	29.6	17	4.1
$\phi 6$	KQG2P-06	8	30.8	17.2	8.5
$\phi 8$	KQG2P-08	10	33.7	17.6	15.5
$\phi 10$	KQG2P-10	12	34.6	17.6	24.1
$\phi 12$	KQG2P-12	14	36.5	17.9	35.8
$\phi 16$	KQG2P-16	18	38.6	17.8	65.5

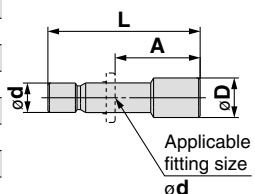

Stainless Steel 316 One-touch Fittings

Applicable Tube: Inch Size, Connection Thread: UNF, NPT

Series **KQG2**

RoHS



Applicable Tube

Tube material	FEP, PFA, Nylon, Soft nylon ^{Note 1)} , Polyurethane, Polyolefin
Tube O.D.	ø1/8", ø5/32", ø1/4", ø5/16", ø3/8", ø1/2"

Specifications

Fluid	Air, Water, Steam ^{Note 2)} ^{Note 3)}
Operating pressure range ^{Note 4)}	-100 kPa to 1 MPa ^{Note 5)}
Proof pressure	3.0 MPa
Ambient and fluid temperature ^{Note 6)}	-5 to 150°C (No freezing) ^{Note 5)}
Lubricant	Grease-free specification
Seal on the threads	With sealant

Note 1) For soft nylon tube, water cannot be used.

Note 2) Consult with SMC regarding applicable tube separately.

Note 3) Using special FKM that is resistant even when steam is used.

Note 4) Avoid using in a vacuum holding application such as a leak tester, since there is leakage.

Note 5) Check the operating pressure range and operating temperature range of the tube.

Note 6) It is recommended that you use the inner sleeve in the following conditions (Except ø1/8"):

- When using in an environment where the fluid temperature changes drastically.
- When using at a high temperature.

* Temperature Condition of Mounting the Inner Sleeve

Tube	Temperature
FEP tube/TH series	80°C or more
PFA tube/TL series	120°C or more

Spare Parts

Description	Tube O.D.	Part no.	Material
Gasket	—	M-5G3	Stainless steel 316, Special FKM
Bulkhead nut	ø1/8", ø5/32"	KQG201-P01	Stainless steel 316
	ø1/4"	KQG207-P01	
	ø5/16"	KQG209-P01	
	ø3/8"	KQG211-P01	
	ø1/2"	KQG213-P01	

Cross Reference Table of the Inner Sleeve

Tube O.D.	Tube material		Applicable inner sleeve	
	TH/THI (FEP)	TL/TIL (PFA)	Part no.	Length
ø5/32"	TH0402	—	TJG-0402	18
	TH0425	—	TJG-0425	18
	—	TL0403	TJG-0403	18
ø1/4"	TIHB07	TIL07	TJG-0604	19
	TIHA07	—	TJG-0746	19
ø5/16"	TH0806	TL0806	TJG-0806	20.5
ø3/8"	TIHB11	TIL11	TJG-1065	23
	TIHA11	—	TJG-1107	23
ø1/2"	TIH13	TIL13	TJG-1395	24

* Stainless steel 316 is used for the TJG series.

Construction

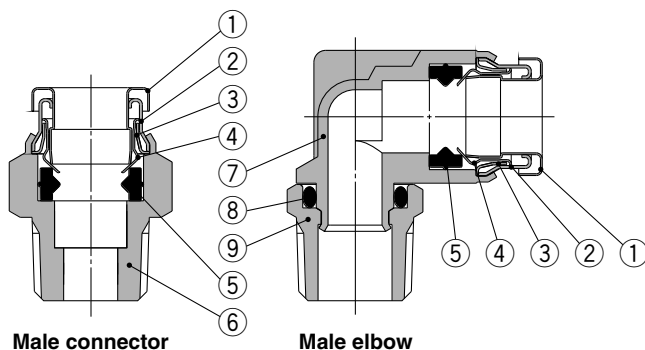

Component Parts

No.	Description	Material
1	Release button	Stainless steel 316
2	Guide 1	Stainless steel 316
3	Guide 2	Stainless steel 316
4	Chuck	Stainless steel 316
5	Seal	Special FKM (Fluoro coated)
6	Male connector body	Stainless steel 316
7	Male elbow body	Stainless steel 316
8	O-ring	Special FKM (Fluoro coated)
9	Stud	Stainless steel 316

Series KQG2

Applicable Tube: Inch Size, Connection Thread: UNF, NPT

Dimensions

Male Connector: KQG2H



Applicable tube O.D. (inch)	Connection thread UNF, NPT	Model	H (Width across flat)	Note 1) ϕD	L	A*	M	Note 2) Effective area (mm ²)	Weight (g)
$\phi 1/8$ "	10-32UNF	KQG2H01-32	8	8	16.5	13.5	12	3	3.3
	1/8	KQG2H01-N01S	12		17.1	13.9			
	1/4	KQG2H01-N02S	14		20.9	16.5			
$\phi 5/32$ "	10-32UNF	KQG2H03-32	10	8.7	17.1	14.1	12.6	4	5
	1/8	KQG2H03-N01S	12		17	13.8			
	1/4	KQG2H03-N02S	14		20.9	16.5			
$\phi 1/4$ "	10-32UNF	KQG2H07-32	12	11.2	19	16	13.5	4	7.5
	1/8	KQG2H07-N01S	12		20	16.8			
	1/4	KQG2H07-N02S	14		20.6	16.2			
	3/8	KQG2H07-N03S	19		23.8	19.1			
$\phi 5/16$ "	1/8	KQG2H09-N01S	14	13.4	24.2	21	16.1	26.1	12.6
	1/4	KQG2H09-N02S	14		23.1	18.7			
	3/8	KQG2H09-N03S	19		24.6	19.9			
$\phi 3/8$ "	1/8	KQG2H11-N01S	17	16	25	21.8	16.6	26.1	19.4
	1/4	KQG2H11-N02S	17		26.3	21.9			
	3/8	KQG2H11-N03S	19		23.6	18.9			
	1/2	KQG2H11-N04S	22		28.3	21.9			
$\phi 1/2$ "	1/4	KQG2H13-N02S	22	19.3	30.5	26.1	18.5	58.3	36.7
	3/8	KQG2H13-N03S	22		28.4	23.7			
	1/2	KQG2H13-N04S	22		22	22			

(10-32UNF)

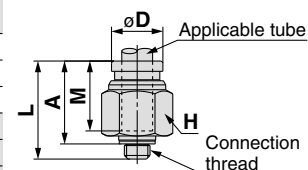

(NPT)

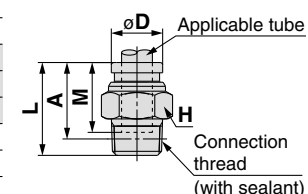

* Reference dimensions after installation of NPT thread
 Note 1) ϕD is maximum diameter.
 Note 2) Value of FEP tube.

Hexagon Socket Head Male Connector: KQG2S



Applicable tube O.D. (inch)	Connection thread UNF, NPT	Model	H (Width across flat)	Note 1) ϕD	L	A*	M	Note 2) Effective area (mm ²)	Weight (g)	
$\phi 1/8$ "	10-32UNF	KQG2S01-32	2	9	16.5	13.5	12	3	3.8	
$\phi 5/32$ "	10-32UNF	KQG2S03-32	2	9	17.1	14.1	12.6	4	3.7	
	1/8	KQG2S03-N01S	2.78	11	19.6	16.4		4.1	8.5	
$\phi 1/4$ "	10-32UNF	KQG2S07-32	2	12	19.5	16.5	13.5	4	7.2	
	1/8	KQG2S07-N01S	4.76		14	20.5		17.3	10	8.1
	1/4	KQG2S07-N02S	4.76		14	20.5		16.1	10.7	13.4
	3/8	KQG2S07-N03S	4.76		18	23.6		15.8	10.7	22.6
$\phi 5/16$ "	1/8	KQG2S09-N01S	5.56	14	24.7	21.5	16.1	17.2	12	
	1/4	KQG2S09-N02S	6.35		23.1	18.7		23.3	12.8	
	3/8	KQG2S09-N03S	6.35		18	23.1		18.4	23.3	23.5
$\phi 3/8$ "	1/8	KQG2S11-N01S	5.56	17	25.2	22	16.6	17.2	17.8	
	1/4	KQG2S11-N02S	6.35		27.1	22.7		39	21.2	
	3/8	KQG2S11-N03S	6.35		18	23.6		18.9	39	23.8
	1/2	KQG2S11-N04S	6.35		22	23.6		17.2	39	38.6
$\phi 1/2$ "	1/4	KQG2S13-N02S	8	20	30.5	26.1	18.5	46	26.6	
	3/8	KQG2S13-N03S	9.53		29.4	24.7		60	29	
	1/2	KQG2S13-N04S	9.53		22	25.5		19.1	60	34.8

(10-32UNF)

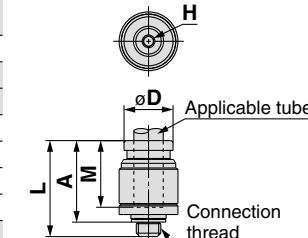

(NPT)

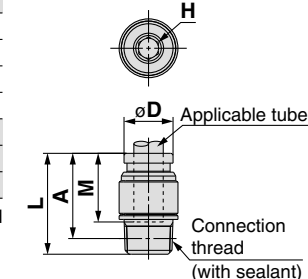

* Reference dimensions after installation of NPT thread
 Note 1) ϕD is maximum diameter.
 Note 2) Value of FEP tube.

Straight Union: KQG2H



Applicable tube O.D. (inch)	Model	ϕD Note 1)	L	M	Note 2) Effective area (mm ²)	Weight (g)
$\phi 1/8$ "	KQG2H01-00	9	25	12	3.4	6.5
$\phi 5/32$ "	KQG2H03-00	9	26.2	12.6	5.6	6.5
$\phi 1/4$ "	KQG2H07-00	12	28	13.5	13.1	11
$\phi 5/16$ "	KQG2H09-00	14	33.2	16.1	26.1	16.6
$\phi 3/8$ "	KQG2H11-00	16	34.2	16.6	41.5	22.7
$\phi 1/2$ "	KQG2H13-00	20	38	18.5	58.3	35.5

2 x Applicable tube

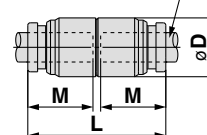

Note 1) ϕD is maximum diameter.
 Note 2) Value of FEP tube.

Dimensions

Male Elbow: KQG2L

Applicable tube O.D. (inch)	Connection thread UNF, NPT	Model	H (Width across flat)	Note 1) ϕD	L1	L2	A*	M	Note 2) Effective area (mm ²)	Weight (g)
$\phi 1/8"$	10-32UNF	KQG2L01-32	8	8.3	13.1	14.8	16	12	2.6	6.3
	1/8	KQG2L01-N01S	12		13.6	14.9	15.8		3	9
	1/4	KQG2L01-N02S	14		18.7	18.4	16.7			
$\phi 5/32"$	10-32UNF	KQG2L03-32	8	9.1	13.7	15.2	16.8	12.6	3.5	6.9
	1/8	KQG2L03-N01S	12		14.4	15.3	16.6		4.2	9.9
	1/4	KQG2L03-N02S	14		19.1	19.2	17.6			
$\phi 1/4"$	10-32UNF	KQG2L07-32	8	11.7	14.7	16.5	19.3	13.5	3.5	8.9
	1/8	KQG2L07-N01S	12		16.6	19.2	11.4		11.7	
	1/4	KQG2L07-N02S	14		15.9	20.4	21.8		19.4	
	3/8	KQG2L07-N03S	19		22.2	23.3	34.2			
$\phi 5/16"$	1/8	KQG2L09-N01S	12	13.7	18.6	18.3	21.9	16.1	21.6	15.1
	1/4	KQG2L09-N02S	14		19.1	21.5	23.9		21.1	
	3/8	KQG2L09-N03S	19		23.3	25.4	35.7			
$\phi 3/8"$	1/8	KQG2L11-N01S	12	16	20	19.4	24.2	16.6	21.6	19.7
	1/4	KQG2L11-N02S	14		22.6	26.2	35.2		23.2	
	3/8	KQG2L11-N03S	19		21	24.4	27.7		36.7	
	1/2	KQG2L11-N04S	22		28.2	29.8	60.2			
$\phi 1/2"$	1/4	KQG2L13-N02S	14	19.6	22.7	24.4	29.8	18.5	50.2	29.4
	3/8	KQG2L13-N03S	19		23.7	26.1	31.2		39.2	
	1/2	KQG2L13-N04S	22		29.9	33.3	61.3			

* Reference dimensions after installation of NPT thread
Note 1) ϕD is maximum diameter.
Note 2) Value of FEP tube.

(10-32UNF)

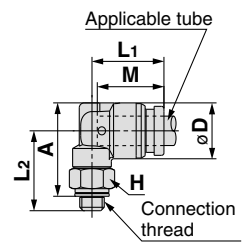

(NPT)

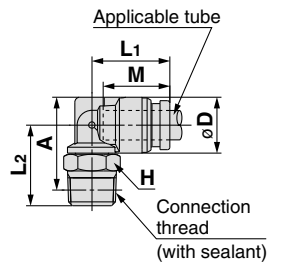

Male Branch Tee: KQG2T

Applicable tube O.D. (inch)	Connection thread UNF, NPT	Model	H (Width across flat)	Note 1) ϕD	L1	L2	A*	M	Note 2) Effective area (mm ²)	Weight (g)
$\phi 1/8"$	10-32UNF	KQG2T01-32	8	8.3	13.1	14.8	16	12	3.2	8.1
	1/8	KQG2T01-N01S	12		13.6	14.9	15.8		3.4	10.8
	1/4	KQG2T01-N02S	14		18.7	18.4	18.5			
$\phi 5/32"$	10-32UNF	KQG2T03-32	8	9.1	13.7	15.2	16.8	12.6	4.5	9
	1/8	KQG2T03-N01S	12		14.4	15.3	16.6		6	11.8
	1/4	KQG2T03-N02S	14		19.1	19.2	19.5			
$\phi 1/4"$	10-32UNF	KQG2T07-32	8	11.7	14.7	16.5	19.3	13.5	4.5	12.1
	1/8	KQG2T07-N01S	12		16.6	19.2	13.9		15.1	
	1/4	KQG2T07-N02S	14		15.9	20.4	21.8		22.8	
	3/8	KQG2T07-N03S	19		22.2	23.3	37.7			
$\phi 5/16"$	1/8	KQG2T09-N01S	12	13.7	18.6	18.3	21.9	16.1	26.3	20.4
	1/4	KQG2T09-N02S	14		19.1	21.5	23.9		26.3	
	3/8	KQG2T09-N03S	19		23.3	25.4	41			
$\phi 3/8"$	1/8	KQG2T11-N01S	12	16	20	19.4	24.2	16.6	40.8	27.3
	1/4	KQG2T11-N02S	14		22.6	26.2	30.5			
	3/8	KQG2T11-N03S	19		21	24.4	27.7		44	
	1/2	KQG2T11-N04S	22		28.2	29.8	67.4			
$\phi 1/2"$	1/4	KQG2T13-N02S	14	19.6	22.7	24.4	29.8	18.5	57.2	41.1
	3/8	KQG2T13-N03S	19		23.7	26.1	31.2		50.2	
	1/2	KQG2T13-N04S	22		29.9	33.3	72.3			

* Reference dimensions after installation of NPT thread
Note 1) ϕD is maximum diameter.
Note 2) Value of FEP tube.

(10-32UNF)

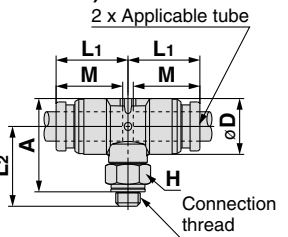

(NPT)

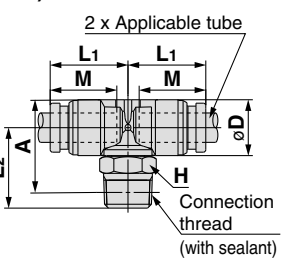

Union Elbow: KQG2L

Applicable tube O.D. (inch)	Model	Note 1) ϕD	L	A	Q	M	ϕN	ϕO	Note 2) Effective area (mm ²)	Weight (g)
$\phi 1/8"$	KQG2L01-00	8.3	13.6	19.3	2.9	12	3.2	5.6	3	6.3
$\phi 5/32"$	KQG2L03-00	9.1	14.6	20.5	3.1	12.6	3.2	5.6	4.2	7.4
$\phi 1/4"$	KQG2L07-00	11.7	16.7	23.2	3.7	13.5	3.2	5.6	11.4	11.5
$\phi 5/16"$	KQG2L09-00	13.7	20.1	29.1	5	16.1	4.2	8	21.6	20.2
$\phi 3/8"$	KQG2L11-00	16	21.4	31.1	5.7	16.6	4.2	8	35.2	28.2
$\phi 1/2"$	KQG2L13-00	19.6	24.9	35.3	6.4	18.5	4.2	8	50.2	41.7

Note 1) ϕD is maximum diameter.
Note 2) Value of FEP tube.

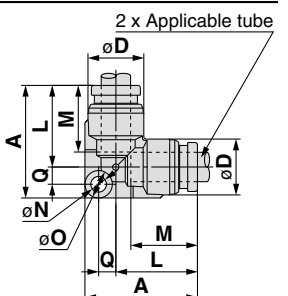

Series KQG2

Applicable Tube: Inch Size, Connection Thread: UNF, NPT

Dimensions

Bulkhead Union: KQG2E



Applicable tube O.D. (inch)	Model	T (UNF)	H (Width across flat)	L	Mounting hole	M	Note 2) Effective area (mm ²)	Weight (g)
ø1/8"	KQG2E01-00	7/16-20UNF	14	34.2	12.5	12	3.4	20.7
ø5/32"	KQG2E03-00	7/16-20UNF	14	34.4	12.5	12.6	5.6	20.5
ø1/4"	KQG2E07-00	1/2-20UNF	17	35.4	14	13.5	13.1	28
ø5/16"	KQG2E09-00	5/8-18UNF	19	39.6	17	16.1	26.1	39.5
ø3/8"	KQG2E11-00	3/4-16UNF	22	40.4	20.5	16.6	41.5	57.3
ø1/2"	KQG2E13-00	7/8-14UNF	26	44.4	23.5	18.5	58.3	83.2

Note) Value of FEP tube.

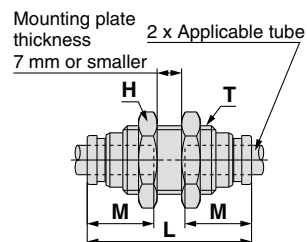

Union Tee: KQG2T



Applicable tube O.D. (inch)	Model	Note 1) øD	L	A	Q	M	øN	øO	Note 2) Effective area (mm ²)	Weight (g)
ø1/8"	KQG2T01-00	8.3	13.6	20.5	4.1	12	3.2	5.6	3.4	7.9
ø5/32"	KQG2T03-00	9.1	14.6	21.8	4.4	12.6	3.2	5.6	6.4	9.5
ø1/4"	KQG2T07-00	11.7	16.7	24.7	5.2	13.5	3.2	5.6	13.4	14.7
ø5/16"	KQG2T09-00	13.7	20.1	31.1	7	16.1	4.2	8	25.6	24.4
ø3/8"	KQG2T11-00	16	21.4	33.4	8	16.6	4.2	8	40	34.7
ø1/2"	KQG2T13-00	19.6	24.9	37.9	9	18.5	4.2	8	57.4	52.3

Note 1) øD is maximum diameter.
Note 2) Value of FEP tube.

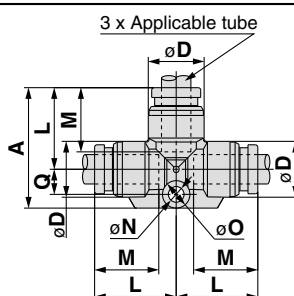

Union "Y": KQG2U



Applicable tube O.D. (inch)	Model	Note 1) øD	W	L1	L2	P	M	øN	øO	Note 2) Effective area (mm ²)	Weight (g)
ø1/8"	KQG2U01-00	8.3	16.4	29	11	8.1	12	3.2	5.6	3.4	9.2
ø5/32"	KQG2U03-00	9.1	18.2	30.4	11.3	9.1	12.6	3.2	5.6	4.2	11.1
ø1/4"	KQG2U07-00	11.7	23.9	34.5	12.1	12.2	13.5	3.2	5.6	13.4	19.6
ø5/16"	KQG2U09-00	13.7	28.3	40.1	14.1	14.6	16.1	4.2	8	25.6	29.7
ø3/8"	KQG2U11-00	16	33.2	42.2	14	17.2	16.6	4.2	8	40	43.1
ø1/2"	KQG2U13-00	19.6	40.2	47.3	15.8	20.6	18.5	4.2	8	57.4	66.4

Note 1) øD is maximum diameter.
Note 2) Value of FEP tube.

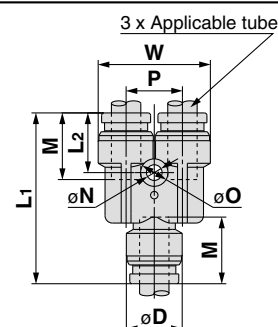

Different Diameter Tee: KQG2T



Applicable tube O.D. (inch)	Model	Note 1) øD1	Note 1) øD2	L1	L2	L3	Q	M1	M2	øN	øO	Note 2) Effective area (mm ²)	Weight (g)
ø1/8" ø5/32"	KQG2T01-03	9.1	8.3	14.2	14.1	21.1	4.1	12.6	12	3.2	5.6	3.8	8.5
ø5/32" ø1/4"	KQG2T03-07	11.7	9.1	15.5	15.9	22.7	4.4	13.5	12.6	3.2	5.6	7.1	11.7
ø1/4" ø5/16"	KQG2T07-09	13.7	11.7	19.3	17.6	29.6	6.3	16.1	13.5	4.2	8	16.4	20.2
ø5/16" ø3/8"	KQG2T09-11	16	13.7	20.6	21	31.7	7.1	16.6	16.1	4.2	8	36	28.9
ø3/8" ø1/2"	KQG2T11-13	19.6	16	23.3	23	35.4	8.1	18.5	16.6	4.2	8	56	41.8

Note 1) øD1, øD2 are maximum diameters.
Note 2) Value of FEP tube.

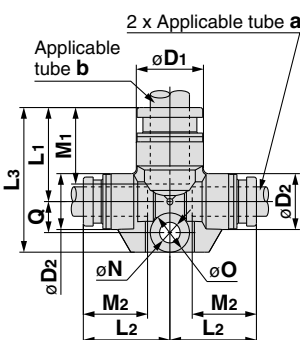

Plug-in Reducer: KQG2R



Applicable tube O.D. (inch)	Applicable fitting size ød	Model	Note 1) øD	L	A	M	Note 2) Effective area (mm ²)	Weight (g)
ø1/8"	ø5/32"	KQG2R01-03	9	32.9	20.3	12	3.4	4.7
ø5/32"	ø1/4"	KQG2R03-07	9	33.7	20.2	12.6	5.6	7.1
ø1/4"	ø5/16"	KQG2R07-09	12	38.4	22.3	13.5	13.1	11.9
ø5/16"	ø3/8"	KQG2R09-11	14	41.6	25	16.1	26.1	16.8
ø3/8"	ø1/2"	KQG2R11-13	17	39.8	21.3	16.6	41.5	23.5

Note 1) øD is maximum diameter.
Note 2) Value of FEP tube.

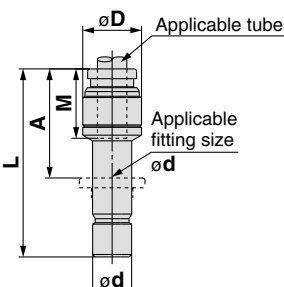

Dimensions

Different Diameter Straight: KQG2H



Applicable tube O.D. (inch)		Model	øD Note 1)	L	M1	M2	Note 2) Effective area (mm ²)	Weight (g)
a	b							
ø1/8"	ø5/32"	KQG2H01-03	9	25.6	12	12.6	3.4	6.5
ø5/32"	ø1/4"	KQG2H03-07	12	27.1	12.6	13.5	5.6	11.3
ø1/4"	ø5/16"	KQG2H07-09	14	30.6	13.5	16.1	13.1	16.1
ø5/16"	ø3/8"	KQG2H09-11	16	33.7	16.1	16.6	26.1	22.8
ø3/8"	ø1/2"	KQG2H11-13	20	36.1	16.6	18.5	41.5	37.1

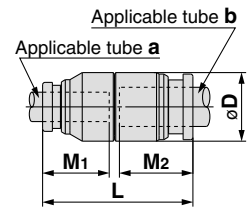

Note 1) øD is maximum diameter.
Note 2) Value of FEP tube.

Different Diameter Union "Y": KQG2U



Applicable tube O.D. (inch)		Model	Note 1) øD	L1	L2	P	W	M1	M2	øN	øO	Note 2) Effective area (mm ²)	Weight (g)
a	b												
ø1/8"	ø5/32"	KQG2U01-03	9.1	27	10.8	8.1	16.4	12	12.6	3.2	5.6	3.2	8.5
ø5/32"	ø1/4"	KQG2U03-07	11.7	28.8	11.4	9.1	18.2	12.6	13.5	3.2	5.6	4.2	11.8
ø1/4"	ø5/16"	KQG2U07-09	13.7	33.8	12	12.2	23.9	13.5	16.1	4.2	8	13.4	20
ø5/16"	ø3/8"	KQG2U09-11	16	38.3	13.8	14.6	28.3	16.1	16.6	4.2	8	25.6	31
ø3/8"	ø1/2"	KQG2U11-13	19.6	40.5	13.7	17.2	33.2	16.6	18.5	4.2	8	40	45

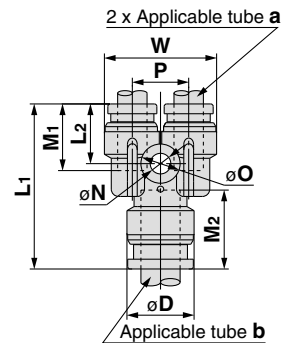

Note 1) øD is maximum diameter.
Note 2) Value of FEP tube.

Bulkhead Connector: KQG2E



Applicable tube O.D. (inch)	Connection thread NPT	Model	T (UNF)	Width across flat		L1	L2	Mounting hole	M	Note) Effective area (mm ²)	Weight (g)
				H1	H2						
ø1/8"	1/4	KQG2E01-N02	7/16-20UNF	17	14	32.8	15.3	12.5	12	3.4	30.6
ø5/32"	1/4	KQG2E03-N02	7/16-20UNF	17	14	32.6	15.3	12.5	12.6	5.6	30.1
ø1/4"	1/4	KQG2E07-N02	1/2-20UNF	17	17	32.7	14.8	14	13.5	13.1	32.6
ø5/16"	3/8	KQG2E09-N03	5/8-18UNF	19	19	35	15.1	17	16.1	26.1	38.2
ø3/8"	3/8	KQG2E11-N03	3/4-16UNF	21	22	33.8	13.3	20.5	16.6	41.5	51.7
ø1/2"	3/8	KQG2E13-N03	7/8-14UNF	24	26	34.6	12.3	23.5	18.5	58.3	73.2
	1/2	KQG2E13-N04									

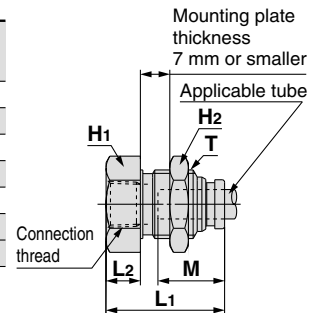

Note) Value of FEP tube.

Extended Male Elbow: KQG2W



Applicable tube O.D. (inch)	Connection thread NPT	Model	H (Width across flat)	Note 1) øD	L1	L2	A*	M	Note 2) Effective area (mm ²)	Weight (g)
	1/4	KQG2W01-N02S	14	35.4	35.1	34.4				
ø5/32"	1/8	KQG2W03-N01S	12	9.1	14.4	32	33.3	12.6	4	22.4
	1/4	KQG2W03-N02S	14			35.8	35.9			35.2
ø1/4"	1/8	KQG2W07-N01S	12	11.7	15.9	33.3	35.9	13.5	10.9	24.1
	1/4	KQG2W07-N02S	14			37.1	38.5			37
ø5/16"	3/8	KQG2W07-N03S	19	13.7	19.1	38.9	40	16.1	20.5	70.9
	1/8	KQG2W09-N01S	12			18.6	34.7			38.3
ø1/2"	1/4	KQG2W09-N02S	14	19.6	23.7	40.2	42.6	18.5	47.7	38.7
	3/8	KQG2W09-N03S	19			42	44.1			74.7
ø3/8"	1/4	KQG2W11-N02S	14	16	21	47.2	50.8	16.6	33.5	41.8
	3/8	KQG2W11-N03S	19			45.4	48.7			75.2
ø1/2"	1/2	KQG2W11-N04S	22	19.6	23.7	49.2	50.8	18.5	47.7	116.5
	1/4	KQG2W13-N02S	14			22.7	49			54.4
ø1/2"	3/8	KQG2W13-N03S	19	19.6	23.7	50.7	55.8	18.5	47.7	75.3
	1/2	KQG2W13-N04S	22			54.5	57.9			118.3

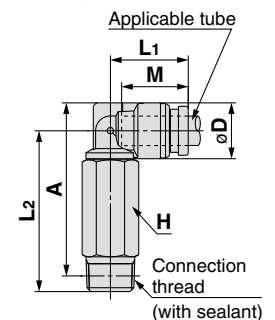

* Reference dimensions after installation of NPT thread
Note 1) øD is maximum diameter.
Note 2) Value of FEP tube.

Series KQG2

Applicable Tube: Inch Size, Connection Thread: UNF, NPT

Dimensions

Female Connector: KQG2F



Applicable tube O.D. (inch)	Connection thread NPT	Model	H (Width across flat)	Note 1) ϕD	L1	L2	M	Note 2) Effective area (mm ²)	Weight (g)
$\phi 1/8$ "	1/8	KQG2F01-N01	12	8	24.1	10.4	12	3.4	9.4
	1/4	KQG2F01-N02	17		29.1	13.7			22.5
$\phi 5/32$ "	1/8	KQG2F03-N01	12	8.7	24.6	10.5	12.6	5.6	9.9
	1/4	KQG2F03-N02	17		29.6	13.8			23
$\phi 1/4$ "	1/8	KQG2F07-N01	12	11.2	25	10.7	13.5	13.1	11.1
	1/4	KQG2F07-N02	17		30	14.1			24.5
	3/8	KQG2F07-N03	19		31.2	14.6			25.5
$\phi 5/16$ "	1/8	KQG2F09-N01	14	13.4	27.2	10.3	16.1	26.1	17.3
	1/4	KQG2F09-N02	17		32.2	14.3			26.9
	3/8	KQG2F09-N03	19		33.4	14.8			28.1
$\phi 3/8$ "	1/4	KQG2F11-N02	17	16	32.1	14.4	16.6	41.5	29.7
	3/8	KQG2F11-N03	19		33.3	14.9			30.9
	1/2	KQG2F11-N04	24		38.6	18.6			49.1
$\phi 1/2$ "	3/8	KQG2F13-N03	21	19.3	34.6	14.7	18.5	58.3	43.3
	1/2	KQG2F13-N04	24		39.9	18.8			53.5

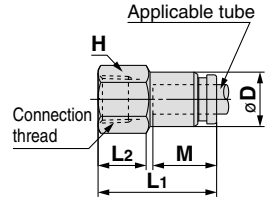

Note 1) ϕD is maximum diameter.
Note 2) Value of FEP tube.

Plug: KQG2P



Applicable fitting size ϕd	Model	ϕD	L	A	Weight (g)
$\phi 1/8$ "	KQG2P-01	5	28.9	16.9	2.7
$\phi 5/32$ "	KQG2P-03	6	29.6	17	4.1
$\phi 1/4$ "	KQG2P-07	8	30.3	16.8	8.9
$\phi 5/16$ "	KQG2P-09	10	33.7	17.6	15.5
$\phi 3/8$ "	KQG2P-11	11	34.1	17.5	21
$\phi 1/2$ "	KQG2P-13	14	36.4	17.9	38.5

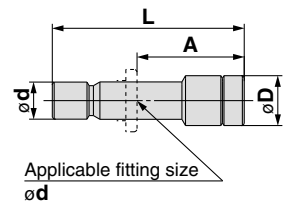



Series KQG2

Specific Product Precautions

Be sure to read before handling. Refer to back cover for Safety Instructions, "Handling Precautions for SMC Products" (M-E03-3) for Fittings and Tubing Precautions.

Selection

⚠ Caution

1. The surge pressure must be under the maximum operating pressure. If the surge pressure exceeds the maximum operating pressure, it will result in damage to fittings and tubes or the tube may result in being fallen out.
2. If using a fluororesin tube in an environment where the fluid temperature changes drastically, it is recommended to use an inner sleeve. Otherwise, air leakage may occur or the tube may release from fitting due to deformation of the tube.
3. The particle generation of the KQG2 series depends on the operating conditions and operating environment. If you are concerned about the effects on machinery and equipment, check the particle generation with your machine before use.

The components of the KQG2 series may slide due to changes in the internal pressure, which may generate particles. When using male elbow, male branch tee, and extended male elbow fittings, particles may be generated by rotation for positioning after connecting.

Mounting

⚠ Caution

1. When performing the piping work, turn the tightening tool in the horizontal direction to the hex. across flats of the stud so that any moment is not applied to the body.

If the tool is in contact with the body, this may cause the stud to come off.

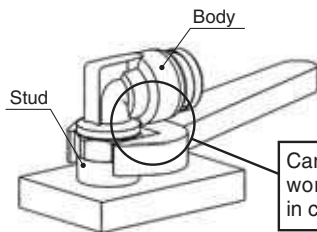

2. The union elbow, union tee, union "Y", different diameter tee and different diameter union "Y" should be fixed through the mounting hole.

Otherwise, air leakage or breaking can occur due to a pulling force or moment load created by the product's weight.

3. The elbow union, branch tee, and long elbow union can be turned for positioning after connecting, but they cannot be used while turning them.

Doing so may cause worn out metallic particles to enter the fluid or the fitting to break.

4. If the connection tube oscillates or turns, do not use this product.

Doing so may cause the fitting to break. In particular, for the product with the stud, this may cause the stud to come off.

Operating Environment

⚠ Warning

1. Avoid installing and using fittings inside a food zone.

Not installable

Food zone An environment where food which will be sold as merchandise, directly touches the fitting components.

Installable

Splash zone An environment where food which will not be sold as merchandise, directly touches the fitting components.

Non-food zone An environment where there is no contact with food.

Installation and Removal of Tube

⚠ Caution

1. Installation of tube

1) Grease is not used for the KQG2 series, therefore a greater insertion force is required when the tube is installed. In particular, polyurethane tube may fold when inserted due to its softness. Hold the end of the tube, and insert it all the way in slowly and securely. Refer to dimension "M" in the dimension drawings for guidance on the insertion depth of tube.

2. Removal of tube

1) For tube used at a high temperature or for an extended period of time, there is a possibility that it will not fit into a one-touch fitting again due to an enlarged O.D. Dispose of the tube and replace it with a new one.

Proper Tightening Torque of Fittings

⚠ Caution

1. Tighten fittings with sealant using the proper tightening torques in the table below. As a rule, they should be tightened 2 to 3 turns with a tool after first tightening by hand.

If tightened using a torque exceeding the proper torque level, this may cause the fitting to break.

In particular, for the product with the stud, the stud may come off.

Connection thread size	Proper tightening torque N·m
NPT, R1/8	7 to 9
NPT, R1/4	12 to 14
NPT, R3/8	22 to 24
NPT, R1/2	28 to 30

Stainless steel

Metal exists in nature as ore (like oxide or sulfide). This means that oxide or sulfide is more stable than pure metal. Accordingly, metallic material chemically oxidizes (metallic constituent becomes ion and melts out). It corrodes in the natural environment.

Even though corrosion of metal easily occurs in an environment where oxidizing tendency is stronger, some kinds of metal have a characteristic for which corrosion never happens if the level of oxidizing goes higher than a specific point. In such a case, it is called "metal in passive state".

Stainless steel has corrosion resistance because of a thin coat of passive state on its surface. However, there does not exist stainless steel with absolute corrosion resistance; therefore, many types of stainless steel have been developed for improved corrosion resistance performance.

Variations

Male Connector

KFG2H



Metric P. 17
Inch P. 22

Bulkhead Union

KFG2E



Metric P. 19
Inch P. 23

Male Elbow

KFG2L



Metric P. 17
Inch P. 22

Union Elbow

KFG2L



Metric P. 19
Inch P. 23

Male Branch Tee

KFG2T



Metric P. 18
Inch P. 22

Swivel Elbow

KFG2V



Metric P. 19
Inch P. 24

Straight Union

KFG2H



Metric P. 18
Inch P. 23

Female Connector

KFG2F



Metric P. 20
Inch P. 24

Union Tee

KFG2T



Metric P. 18
Inch P. 23

Union Nut

KFG2N



Metric P. 20
Inch P. 24

Stainless Steel 316 Insert Fittings

Applicable Tube: Metric Size, Connection Thread: R, Rc

Series **KFG2**

RoHS



Applicable Tube

Tube material ^{Note)}	FEP, PFA, Modified PTFE, Nylon, Soft nylon ^{Note)} , Polyurethane, Soft polyurethane, Polyolefin, Soft polyolefin, Antistatic soft nylon, Antistatic polyurethane, Hard polyurethane
Tube size	ø4 x ø2.5, ø4 x ø3, ø6 x ø4, ø8 x ø6, ø10 x ø7.5, ø10 x ø8, ø12 x ø9, ø12 x ø10, ø16 x ø13

Note) For soft nylon tube, soft polyurethane tube, hard polyurethane tube, antistatic polyurethane tube, water cannot be used.

Series	Tube material	Tube O.D. x I.D. (mm)								
		ø4 x ø2.5	ø4 x ø3	ø6 x ø4	ø8 x ø6	ø10 x ø7.5	ø10 x ø8	ø12 x ø9	ø12 x ø10	ø16 x ø13
TH	FEP	●	—	●	●	●	●	●	●	—
TL	PFA	—	●	●	●	—	●	—	●	—
TD	Modified PTFE	●	—	●	●	●	—	●	—	—
T	Nylon	●	●	●	●	●	—	●	—	●
TS	Soft nylon	●	—	●	●	●	—	●	—	—
TU	Polyurethane	●	—	●	—	—	—	—	—	—
TPH	Polyolefin	●	—	●	●	●	—	●	—	—
TUS	Soft polyurethane	●	—	●	—	—	—	—	—	—
TUH	Hard polyurethane (High pressure)	●	—	●	—	—	—	—	—	—
TPS	Soft polyolefin	●	—	●	—	—	—	—	—	—
TAS	Antistatic soft nylon	●	—	●	—	—	—	—	—	—
TAU	Antistatic polyurethane	●	—	●	—	—	—	—	—	—

Spare Parts

Description	Tube O.D.	Part no.	Material
Bulkhead nut	ø4	KFG204-P01	Stainless steel 316 (Fluoro coated)
	ø6	KFG206-P01	
	ø8	KFG208-P01	
	ø10	KFG210-P01	
	ø12	KFG212-P01	
	ø16	KFG216-P01	

Specifications

Fluid	Air, Water, Steam ^{Note 2)} ^{Note 3)}
Operating pressure range ^{Note 1)}	–100 kPa to 1 MPa ^{Note 4)}
Proof pressure	3.0 MPa
Ambient and fluid temperature	–65 to 260°C (No freezing) ^{Note 4)} [Swivel elbow and with sealant types: –5 to 150°C]
Lubricant	Grease-free specification
Seal on the threads	Without sealant (With sealant type compatible) ^{Note 5)}

Note 1) Avoid using in a vacuum holding application such as a leak tester, since there is leakage.

Note 2) Consult with SMC regarding applicable tube separately.

Note 3) Using special FKM that is resistant even when steam is used.

Note 4) Check the operating pressure range and operating temperature range of the tube.

Note 5) With sealant: Suffix "S" to the end of part number.

Note 6) Union nut is shipped together.

Construction

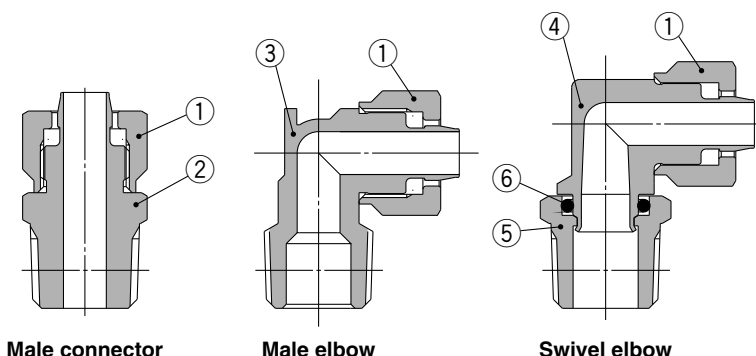

Principal Parts Material

No.	Description	Material	Note
1	Union nut	Stainless steel 316	Fluoro coated
2	Male connector body	Stainless steel 316	
3	Male elbow body	Stainless steel 316	
4	Swivel elbow body	Stainless steel 316	
5	Stud	Stainless steel 316	
6	O-ring	Special FKM	Fluoro coated

Series KFG2

Applicable Tube: Metric Size, Connection Thread: R, Rc

Dimensions

Male Connector: KFG2H



Applicable tube size (mm)		Connection thread R	Model	Width across flat		L	M	ød	A*	Effective area (mm ²)	Weight (g)
O.D.	I.D.			H ₁	H ₂						
ø4	ø2.5	1/8	KFG2H0425-01	10	8	19.4	5	1.8	16.3	1.6	8
		1/4	KFG2H0425-02	14		23.8					14
ø4	ø3	1/8	KFG2H0403-01	10	8	19.4	5	2.3	16.3	2.6	8
		1/4	KFG2H0403-02	14		23.8					14
ø6	ø4	1/8	KFG2H0604-01	10	10	20.9	5.8	3.3	17.8	6	10
		1/4	KFG2H0604-02	14		25.3					16
ø8	ø6	1/8	KFG2H0806-01	14	14	23.3	6.6	5.3	20.2	17	18
		1/4	KFG2H0806-02			26.7					24
		3/8	KFG2H0806-03			28.1					36
ø10	ø7.5	1/4	KFG2H1075-02	17	17	29.7	7.6	6.8	25	30	34
		3/8	KFG2H1075-03			30.1					41
		1/2	KFG2H1075-04			33.5					67
ø10	ø8	1/4	KFG2H1008-02	17	17	29.7	7.6	7.3	25	35	33
		3/8	KFG2H1008-03			30.1					40
		1/2	KFG2H1008-04			33.5					66
ø12	ø9	1/4	KFG2H1209-02	17	17	31.3	8.5	8	26.6	45	33
		3/8	KFG2H1209-03			31.7					40
		1/2	KFG2H1209-04			35.1					66
ø12	ø10	1/4	KFG2H1210-02	17	17	31.3	8.5	9	26.6	57	30
		3/8	KFG2H1210-03			31.7					38
		1/2	KFG2H1210-04			35.1					63
ø16	ø13	3/8	KFG2H1613-03	22	22	33.1	9.3	12	28	101	51
		1/2	KFG2H1613-04			36.3					67

* Reference dimensions after installation of R thread

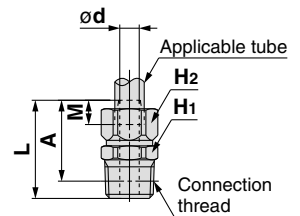

Male Elbow: KFG2L



Applicable tube size (mm)		Connection thread R	Model	Width across flat		L ₁	L ₂	M	ød	A*	Effective area (mm ²)	Weight (g)
O.D.	I.D.			H ₁	H ₂							
ø4	ø2.5	1/8	KFG2L0425-01	10	8	13.5	5	1.8	13.8	1.6	10	
		1/4	KFG2L0425-02								15.9	14
ø4	ø3	1/8	KFG2L0403-01	10	8	13.5	5	2.3	13.8	2.6	10	
		1/4	KFG2L0403-02								15.9	14
ø6	ø4	1/8	KFG2L0604-01	10	10	15	5.8	3.3	16	6	12	
		1/4	KFG2L0604-02								17	16
ø8	ø6	1/8	KFG2L0806-01	12	14	17.4	6.6	5.3	20.4	12	20	
		1/4	KFG2L0806-02								19.2	24
		3/8	KFG2L0806-03								19.6	27
ø10	ø7.5	1/4	KFG2L1075-02	15	17	20.9	7.6	6.8	25.6	23	38	
		3/8	KFG2L1075-03								21.3	41
		1/2	KFG2L1075-04								24.5	51
ø10	ø8	1/4	KFG2L1008-02	15	17	20.9	7.6	7.3	25.6	27	37	
		3/8	KFG2L1008-03								21.3	41
		1/2	KFG2L1008-04								24.5	50
ø12	ø9	1/4	KFG2L1209-02	16	17	23.5	8.5	8	25.6	27	41	
		3/8	KFG2L1209-03								21.3	45
		1/2	KFG2L1209-04								24.5	57
ø12	ø10	1/4	KFG2L1210-02	16	17	23.5	8.5	9	25.6	34	42	
		3/8	KFG2L1210-03								21.3	43
		1/2	KFG2L1210-04								24.5	53
ø16	ø13	3/8	KFG2L1613-03	21	22	26.2	9.3	12	31	79	72	
		1/2	KFG2L1613-04								27.2	78

* Reference dimensions after installation of R thread

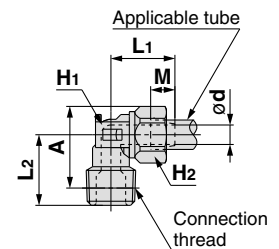

Dimensions

Male Branch Tee: KFG2T



Applicable tube size (mm)		Connection thread R	Model	Width across flat		L ₁	L ₂	M	ød	A*	Effective area (mm ²)	Weight (g)
O.D.	I.D.			H ₁	H ₂							
ø4	ø2.5	1/8	KFG2T0425-01	10	8	13.5	12.5	5	1.8	13.8	3	13
		1/4	KFG2T0425-02				15.9			15.6		17
ø4	ø3	1/8	KFG2T0403-01	10	8	13.5	12.5	5	2.3	13.8	5	12
		1/4	KFG2T0403-02				15.9			15.6		17
ø6	ø4	1/8	KFG2T0604-01	10	10	15	13.6	5.8	3.3	16	10	17
		1/4	KFG2T0604-02				17			17.8		21
ø8	ø6	1/8	KFG2T0806-01	12	14	17.4	15.8	6.6	5.3	20.4	16	30
		1/4	KFG2T0806-02				19.2			22.2		34
		3/8	KFG2T0806-03				19.6			25		38
ø10	ø7.5	1/4	KFG2T1075-02	15	17	20.9	20.9	7.6	6.8	25.6	30	55
		3/8	KFG2T1075-03				21.3			27.5		59
		1/2	KFG2T1075-04				24.5			41		68
ø10	ø8	1/4	KFG2T1008-02	15	17	20.9	20.9	7.3	7.3	25.6	35	54
		3/8	KFG2T1008-03				21.3			27.5		58
		1/2	KFG2T1008-04				24.5			47		67
ø12	ø9	1/4	KFG2T1209-02	16	17	23.5	20.9	8.5	8	25.6	32	59
		3/8	KFG2T1209-03				21.3			27.5		63
		1/2	KFG2T1209-04				24.5			48		72
ø12	ø10	1/4	KFG2T1210-02	16	17	23.5	20.9	8.5	9	25.6	41	57
		3/8	KFG2T1210-03				21.3			27.5		60
		1/2	KFG2T1210-04				24.5			61		69
ø16	ø13	3/8	KFG2T1613-03	21	22	26.2	24	9.3	12	31	108	98
		1/2	KFG2T1613-04				27.2			32.9		106

* Reference dimensions after installation of R thread

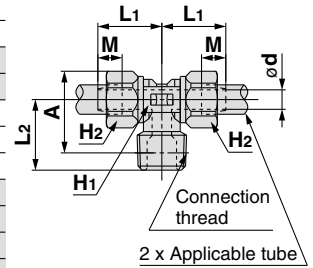

Straight Union: KFG2H



Applicable tube size (mm)		Model	Width across flat		L	M	ød	Effective area (mm ²)	Weight (g)
O.D.	I.D.		H ₁	H ₂					
ø4	ø2.5	KFG2H0425-00	8	8	21.8	5	1.8	1.6	7
		KFG2H0403-00						2.3	
ø6	ø4	KFG2H0604-00	10	10	24.8	5.8	3.3	6	11
ø8	ø6	KFG2H0806-00	14	14	28.6	6.6	5.3	17	25
ø10	ø7.5	KFG2H1075-00	17	17	33.6	7.6	6.8	30	43
ø10	ø8	KFG2H1008-00					7.3	35	42
ø12	ø9	KFG2H1209-00	17	17	37	8.5	8	45	44
ø12	ø10	KFG2H1210-00					9	57	42
ø16	ø13	KFG2H1613-00	22	22	39.4	9.3	12	101	71

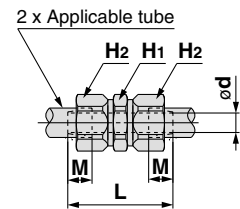

Union Tee: KFG2T



Applicable tube size (mm)		Model	Width across flat		L	M	ød	Effective area (mm ²)	Weight (g)
O.D.	I.D.		H ₁	H ₂					
ø4	ø2.5	KFG2T0425-00	7	8	13.3	5	1.8	1.6	11
		KFG2T0403-00						2.3	
ø6	ø4	KFG2T0604-00	9	10	15.8	5.8	3.3	6	18
ø8	ø6	KFG2T0806-00	12	14	18.7	6.6	5.3	17	39
ø10	ø7.5	KFG2T1075-00	15	17	22.2	7.6	6.8	30	67
ø10	ø8	KFG2T1008-00					7.3	35	65
ø12	ø9	KFG2T1209-00	16	17	24.3	8.5	8	45	71
ø12	ø10	KFG2T1210-00					9	57	67
ø16	ø13	KFG2T1613-00	21	22	28	9.3	12	101	122

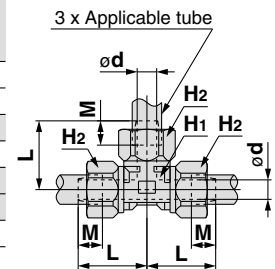

Series KFG2

Applicable Tube: Metric Size, Connection Thread: R, Rc

Dimensions

Bulkhead Union: KFG2E



Applicable tube size (mm)		Model	Width across flat			L1	L2	M	ød	Mounting hole	Effective area (mm ²)	Weight (g)
O.D.	I.D.		H1	H2	H3							
ø4	ø2.5	KFG2E0425-00	12	8	12	32.6	29	5	1.8	11	1.6	16
ø4	ø3	KFG2E0403-00							2.3		2.6	
ø6	ø4	KFG2E0604-00	14	10	14	36.6	32.2	5.8	3.3	13	6	25
ø8	ø6	KFG2E0806-00	17	14	17	40.4	35.8	6.6	5.3	15	17	43
ø10	ø7.5	KFG2E1075-00	21	17	21	44.8	39.4	7.6	6.8	18	30	69
ø10	ø8	KFG2E1008-00							7.3		35	
ø12	ø9	KFG2E1209-00	21	17	21	48.1	41.7	8.5	8	19	45	71
ø12	ø10	KFG2E1210-00							9		57	
ø16	ø13	KFG2E1613-00	27	22	27	52.3	45.9	9.3	12	25	101	122

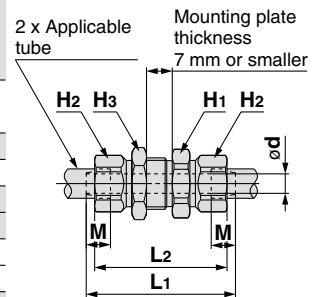

Union Elbow: KFG2L



Applicable tube size (mm)		Model	Width across flat		L	M	ød	Effective area (mm ²)	Weight (g)
O.D.	I.D.		H1	H2					
ø4	ø2.5	KFG2L0425-00	7	8	13.3	5	1.8	1.6	8
ø4	ø3	KFG2L0403-00					2.3	2.6	
ø6	ø4	KFG2L0604-00	9	10	15.8	5.8	3.3	6	13
ø8	ø6	KFG2L0806-00	12	14	18.7	6.6	5.3	17	28
ø10	ø7.5	KFG2L1075-00	15	17	22.2	7.6	6.8	30	47
ø10	ø8	KFG2L1008-00					7.3	35	46
ø12	ø9	KFG2L1209-00	16	17	24.3	8.5	8	45	51
ø12	ø10	KFG2L1210-00					9	57	48
ø16	ø13	KFG2L1613-00	21	22	28	9.3	12	101	89

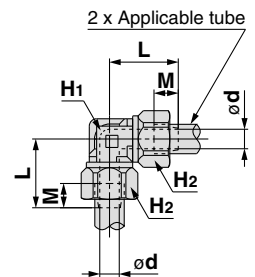

Swivel Elbow: KFG2V



Applicable tube size (mm)		Connection thread R	Model	Width across flat			L1	L2	M	ød	A*	Effective area (mm ²)	Weight (g)
O.D.	I.D.			H1	H2	H3							
ø4	ø2.5	1/8	KFG2V0425-01	7	8	10	14.5	5	1.8	17.4	1.4	9	
		1/4	KFG2V0425-02			14				19.9		18	
ø4	ø3	1/8	KFG2V0403-01			10			2.3	17.4	2.3	9	
		1/4	KFG2V0403-02	14	19.9	18							
ø6	ø4	1/8	KFG2V0604-01	9	10	10	16	5.8	3.3	19.6	5	12	
		1/4	KFG2V0604-02			14				21		21.8	21
ø8	ø6	1/8	KFG2V0806-01	12	14	12	18.4	6.6	5.3	24.7	14	22	
		1/4	KFG2V0806-02			14				20.1		24.7	22
		3/8	KFG2V0806-03			17				23.3		27.3	30
ø10	ø7.5	1/4	KFG2V1075-02	15	17	14	21.4	7.6	6.8	29.6	25	37	
		3/8	KFG2V1075-03			17				26.4		30.6	47
		1/2	KFG2V1075-04			22				30.6		33.5	74
		1/4	KFG2V1008-02			14				25		29.6	36
ø10	ø8	3/8	KFG2V1008-03	15	17	17	26.4	7.3	7.3	30.6	29	46	
		1/2	KFG2V1008-04			22				30.6		33.5	73
		1/4	KFG2V1209-02			14				25		29.6	38
ø12	ø9	3/8	KFG2V1209-03	16	17	17	23	8.5	8	30.6	38	49	
		1/2	KFG2V1209-04			22				30.6		33.5	75
		1/4	KFG2V1210-02			14				25		29.6	40
ø12	ø10	3/8	KFG2V1210-03	16	17	17	24.5	9	9	30.6	48	51	
		1/2	KFG2V1210-04			22				30.6		33.5	77
		3/8	KFG2V1613-03			19				26.7		29.3	75
ø16	ø13	1/2	KFG2V1613-04	21	22	22	26.7	9.3	12	39	86	96	

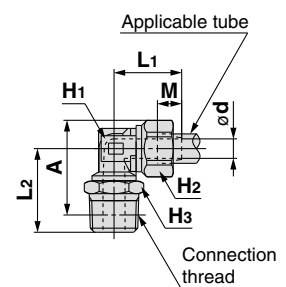

* Reference dimensions after installation of R thread

Dimensions

Female Connector: KFG2F



Applicable tube size (mm)		Connection thread Rc	Model	Width across flat		L1	L2	M	ød	Effective area (mm ²)	Weight (g)
O.D.	I.D.			H1	H2						
ø4	ø2.5	1/4	KFG2F0425-02	17	8	25.9	16.4	5	1.8	1.6	24
ø4	ø3	1/4	KFG2F0403-02						2.3	2.6	
ø6	ø4	1/4	KFG2F0604-02	17	10	26.8	15.8	5.8	3.3	6	25
ø8	ø6	3/8	KFG2F0806-03	19	14	28.8	16.4	6.6	5.3	17	31
ø10	ø7.5	3/8	KFG2F1075-03	19	17	30	15.6	7.6	6.8	30	36
ø10	ø8	3/8	KFG2F1008-03						7.3	35	
ø12	ø9	3/8	KFG2F1209-03	19	17	31.2	15.2	8.5	8	45	36
ø12	ø10	3/8	KFG2F1210-03						9	57	
ø16	ø13	1/2	KFG2F1613-04	24	22	37.7	20.5	9.3	12	101	71

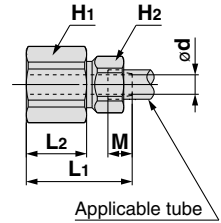

Union Nut: KFG2N



Applicable tube O.D. (mm)	Model	H (Width across flat)	L	Weight (g)
ø4	KFG2N-04	8	7.7	1.9
ø6	KFG2N-06	10	8.8	3
ø8	KFG2N-08	14	10.1	6.7
ø10	KFG2N-10	17	11.7	10.5
ø12	KFG2N-12	17	12.8	9.6
ø16	KFG2N-16	22	14	15.3

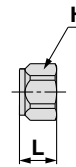

Metric Size **KQG2**

Inch Size **KQG2**

Specific Product Precautions **KQG2**

Metric Size **KFG2**

Inch Size **KFG2**

Specific Product Precautions **KFG2**

Applicable Fluid List

Stainless Steel 316 Insert Fittings

Applicable Tube: Inch Size, Connection Thread: NPT

Series **KFG2**

RoHS



Applicable Tube

Tube material ^{Note}	FEP, PFA, Modified PTFE, Nylon, Soft nylon ^{Note} , Polyurethane, Soft polyurethane, Polyolefin, Soft polyolefin, Antistatic soft nylon, Antistatic polyurethane, Hard polyurethane
Tube size	ø1/8" x ø0.086", ø5/32" x 0.098", ø1/4" x ø5/32" ø5/16" x 0.236", ø3/8" x ø1/4", ø1/2" x ø3/8"

Note) For soft nylon tube, soft polyurethane tube, hard polyurethane tube, antistatic polyurethane tube, water cannot be used.

Series	Tube material	Tube O.D. x I.D. (inch)					
		ø1/8" x ø0.086" (ø3.18 x ø2.18)	ø5/32" x ø0.098" (ø4 x ø2.5)	ø1/4" x ø5/32" (ø6.35 x ø3.95)	ø5/16" x ø0.236" (ø8 x ø6)	ø3/8" x ø1/4" (ø9.53 x ø6.35)	ø1/2" x ø3/8" (ø12.7 x ø9.53)
TH/TH	FEP	●	●	●	●	●	●
TL/TIL	PFA	●	—	●	●	●	●
TD/TID	Modified PTFE	●	●	●	●	●	●
T/TIA	Nylon	●	●	—	●	—	●
TS/TISA	Soft nylon	●	●	—	●	—	●
TU/TIUB	Polyurethane	—	●	—	—	●	—
TPH	Polyolefin	—	●	—	●	—	—
TUS	Soft polyurethane	—	●	—	—	—	—
TUH	Hard polyurethane (High pressure)	—	●	—	—	—	—
TPS	Soft polyolefin	—	●	—	—	—	—
TAS	Antistatic soft nylon	—	●	—	—	—	—
TAU	Antistatic polyurethane	—	●	—	—	—	—

Spare Parts

Description	Tube O.D.	Part no.	Material
Bulkhead nut	ø1/8"	KFG201-P01	Stainless steel 316 (Fluoro coated)
	ø5/32"	KFG203-P01	
	ø1/4"	KFG207-P01	
	ø5/16"	KFG209-P01	
	ø3/8"	KFG211-P01	
	ø1/2"	KFG213-P01	

Specifications

Fluid	Air, Water, Steam ^{Note 2)} ^{Note 3)}
Operating pressure range ^{Note 1)}	-100 kPa to 1 MPa ^{Note 4)}
Proof pressure	3.0 MPa
Ambient and fluid temperature	-65 to 260°C (No freezing) ^{Note 4)} [Swivel elbow and with sealant types: -5 to 150°C]
Lubricant	Grease-free specification
Seal on the threads	Without sealant (With sealant type compatible) ^{Note 5)}

Note 1) Avoid using in a vacuum holding application such as a leak tester, since there is leakage.

Note 2) Consult with SMC regarding applicable tube separately.

Note 3) Using special FKM that is resistant even when steam is used.

Note 4) Check the operating pressure range and operating temperature range of the tube.

Note 5) With sealant: Suffix "S" to the end of part number.

Note 6) Union nut is shipped together.

Construction

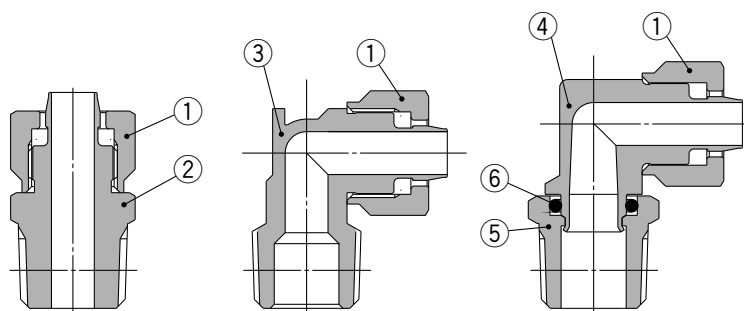

Male connector

Male elbow

Swivel elbow

Principal Parts Material

No.	Description	Material	Note
1	Union nut	Stainless steel 316	Fluoro coated
2	Male connector body	Stainless steel 316	
3	Male elbow body	Stainless steel 316	
4	Swivel elbow body	Stainless steel 316	
5	Stud	Stainless steel 316	
6	O-ring	Special FKM	Fluoro coated

Dimensions

Male Connector: KFG2H



Applicable tube size (inch)		Connection thread NPT	Model	Width across flat		L	M	ød	A*	Effective area (mm ²)	Weight (g)
O.D.	I.D.			H ₁	H ₂						
ø1/8" (ø3.18)	ø0.086" (ø2.18)	1/8	KFG2H0122-N01	12	8	19.4	5	1.5	16.2	1.1	9
		1/4	KFG2H0122-N02	14		23.8			19.4		
ø5/32" (ø4)	ø0.098" (ø2.5)	1/8	KFG2H0325-N01	12	8	19.4	5	1.8	16.2	1.6	9
		1/4	KFG2H0325-N02	14		23.8			19.4		
ø1/4" (ø6.35)	ø5/32" (ø3.95)	1/8	KFG2H0704-N01	12	12	21.1	6	3.3	17.9	6	13
		1/4	KFG2H0704-N02	14		25.5			21.1		
ø5/16" (ø8)	ø0.236" (ø6)	1/8	KFG2H0906-N01	14	14	23.3	6.6	5.3	20.1	17	18
		1/4	KFG2H0906-N02			26.7			22.3		
		3/8	KFG2H0906-N03			28.3			23.6		
ø3/8" (ø9.53)	ø1/4" (ø6.35)	1/4	KFG2H1163-N02	17	17	29.7	7.6	5.6	25.3	19	37
		3/8	KFG2H1163-N03	19		30.3			25.6		
		1/2	KFG2H1163-N04	22		33.5			27.1		70
		1/4	KFG2H1395-N02	19	19	31.5	8.5	8.5	27.1	40.1	40
3/8	KFG2H1395-N03	31.9	27.2								
1/2	KFG2H1395-N04	35.1	28.7								

* Reference dimensions after installation of NPT thread

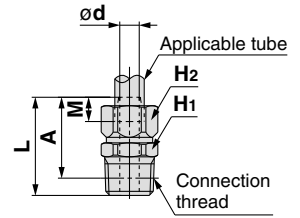

Male Elbow: KFG2L



Applicable tube size (inch)		Connection thread NPT	Model	Width across flat		L ₁	L ₂	M	ød	A*	Effective area (mm ²)	Weight (g)
O.D.	I.D.			H ₁	H ₂							
ø1/8" (ø3.18)	ø0.086" (ø2.18)	1/8	KFG2L0122-N01	10	8	13.5	12.5	5	1.5	13.7	1.1	10
		1/4	KFG2L0122-N02	14		15.9	15.9					
ø5/32" (ø4)	ø0.098" (ø2.5)	1/8	KFG2L0325-N01	10	8	13.5	12.5	5	1.8	13.7	1.6	10
		1/4	KFG2L0325-N02	14		15.9	15.9					
ø1/4" (ø6.35)	ø5/32" (ø3.95)	1/8	KFG2L0704-N01	10	12	15.2	14.7	6	3.3	18.1	6	15
		1/4	KFG2L0704-N02	14		18.1	18.1					
ø5/16" (ø8)	ø0.236" (ø6)	1/8	KFG2L0906-N01	12	14	17.4	15.8	6.6	5.3	20.3	12	20
		1/4	KFG2L0906-N02				19.2			22.5		
		3/8	KFG2L0906-N03				19.6			22.6		
ø3/8" (ø9.53)	ø1/4" (ø6.35)	1/4	KFG2L1163-N02	15	17	20.4	20.9	7.6	5.6	25.9	13	39
		3/8	KFG2L1163-N03				21.3			26.0		
		1/2	KFG2L1163-N04				24.5			27.5		52
		1/4	KFG2L1395-N02	17	19	23.3	21.9	8.5	8.5	27.9	30	48
3/8	KFG2L1395-N03	22.3	28									
1/2	KFG2L1395-N04	25.5	29.5									

* Reference dimensions after installation of NPT thread

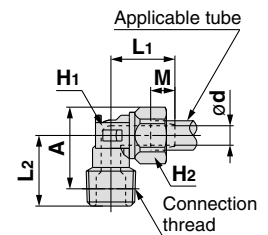

Male Branch Tee: KFG2T



Applicable tube size (inch)		Connection thread NPT	Model	Width across flat		L ₁	L ₂	M	ød	A*	Effective area (mm ²)	Weight (g)
O.D.	I.D.			H ₁	H ₂							
ø1/8" (ø3.18)	ø0.086" (ø2.18)	1/8	KFG2T0122-N01	10	8	13.5	12.5	5	1.5	13.7	2	13
		1/4	KFG2T0122-N02	14		15.9	15.9					
ø5/32" (ø4)	ø0.098" (ø2.5)	1/8	KFG2T0325-N01	10	8	13.5	12.5	5	1.8	13.7	3	13
		1/4	KFG2T0325-N02	14		15.9	15.9					
ø1/4" (ø6.35)	ø5/32" (ø3.95)	1/8	KFG2T0704-N01	10	12	15.2	14.7	6	3.3	18.1	10	22
		1/4	KFG2T0704-N02	14		18.1	18.1					
ø5/16" (ø8)	ø0.236" (ø6)	1/8	KFG2T0906-N01	12	14	17.4	15.8	6.6	5.3	20.3	16	31
		1/4	KFG2T0906-N02				19.2			22.5		
		3/8	KFG2T0906-N03				19.6			22.6		
ø3/8" (ø9.53)	ø1/4" (ø6.35)	1/4	KFG2T1163-N02	15	17	20.4	20.9	7.6	5.6	25.9	18	58
		3/8	KFG2T1163-N03				21.3			26.0		
		1/2	KFG2T1163-N04				24.5			27.5		71
		1/4	KFG2T1395-N02	17	19	23.3	21.9	8.5	8.5	27.9	36	70
3/8	KFG2T1395-N03	22.3	28									
1/2	KFG2T1395-N04	25.5	29.5									

* Reference dimensions after installation of NPT thread

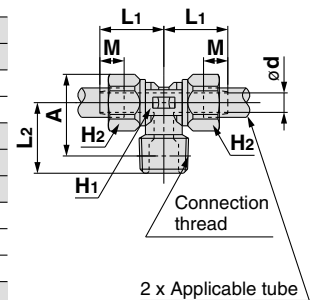

2 x Applicable tube

Series KFG2

Applicable Tube: Inch Size, Connection Thread: NPT

Dimensions

Straight Union: KFG2H

Applicable tube size (inch)		Model	Width across flat		L	M	ød	Effective area (mm ²)	Weight (g)
O.D.	I.D.		H ₁	H ₂					
ø1/8" (ø3.18)	ø0.086" (ø2.18)	KFG2H0122-00	8	8	21.8	5	1.5	1.1	7
ø5/32" (ø4)	ø0.098" (ø2.5)	KFG2H0325-00	8	8	21.8	5	1.8	1.6	7
ø1/4" (ø6.35)	ø5/32" (ø3.95)	KFG2H0704-00	12	12	25.2	6	3.3	6	16
ø5/16" (ø8)	ø0.236" (ø6)	KFG2H0906-00	14	14	28.6	6.6	5.3	17	25
ø3/8" (ø9.53)	ø1/4" (ø6.35)	KFG2H1163-00	17	17	33.6	7.6	5.6	19	45
ø1/2" (ø12.7)	ø3/8" (ø9.53)	KFG2H1395-00	19	19	37	8.5	8.5	51	55

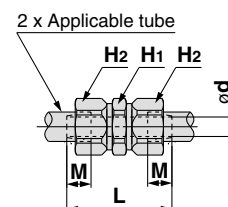

Union Tee: KFG2T

Applicable tube size (inch)		Model	Width across flat		L	M	ød	Effective area (mm ²)	Weight (g)
O.D.	I.D.		H ₁	H ₂					
ø1/8" (ø3.18)	ø0.086" (ø2.18)	KFG2T0122-00	7	8	13.3	5	1.5	1.1	11
ø5/32" (ø4)	ø0.098" (ø2.5)	KFG2T0325-00	7	8	13.3	5	1.8	1.6	11
ø1/4" (ø6.35)	ø5/32" (ø3.95)	KFG2T0704-00	10	12	16.5	6	3.3	6	26
ø5/16" (ø8)	ø0.236" (ø6)	KFG2T0906-00	12	14	18.7	6.6	5.3	17	39
ø3/8" (ø9.53)	ø1/4" (ø6.35)	KFG2T1163-00	15	17	22.2	7.6	5.6	19	70
ø1/2" (ø12.7)	ø3/8" (ø9.53)	KFG2T1395-00	17	19	24.8	8.5	8.5	51	87

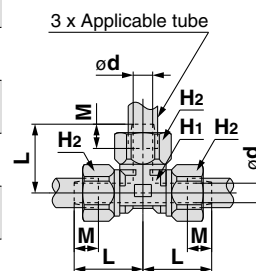

Bulkhead Union: KFG2E

Applicable tube size (inch)		Model	Width across flat			L ₁	L ₂	M	ød	Mounting hole	Effective area (mm ²)	Weight (g)
O.D.	I.D.		H ₁	H ₂	H ₃							
ø1/8" (ø3.18)	ø0.086" (ø2.18)	KFG2E0122-00	12	8	12	32.8	29.4	5	1.5	10	1.1	16
ø5/32" (ø4)	ø0.098" (ø2.5)	KFG2E0325-00	12	8	12	32.6	29	5	1.8	11	1.6	16
ø1/4" (ø6.35)	ø5/32" (ø3.95)	KFG2E0704-00	17	12	17	39	34.6	6	3.3	13.5	6	39
ø5/16" (ø8)	ø0.236" (ø6)	KFG2E0906-00	17	14	17	40.4	35.8	6.6	5.3	15	17	43
ø3/8" (ø9.53)	ø1/4" (ø6.35)	KFG2E1163-00	22	17	22	46.8	41.4	7.6	5.6	20	19	84
ø1/2" (ø12.7)	ø3/8" (ø9.53)	KFG2E1395-00	26	19	26	51.9	45.5	8.5	8.5	23	51	117

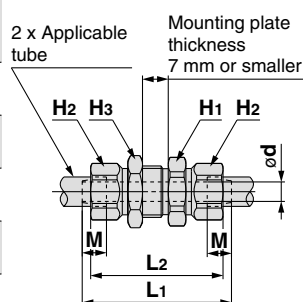

Union Elbow: KFG2L

Applicable tube size (inch)		Model	Width across flat		L	M	ød	Effective area (mm ²)	Weight (g)
O.D.	I.D.		H ₁	H ₂					
ø1/8" (ø3.18)	ø0.086" (ø2.18)	KFG2L0122-00	7	8	13.3	5	1.5	1.1	8
ø5/32" (ø4)	ø0.098" (ø2.5)	KFG2L0325-00	7	8	13.3	5	2.3	1.6	8
ø1/4" (ø6.35)	ø5/32" (ø3.95)	KFG2L0704-00	10	12	16.5	6	3.3	6	18
ø5/16" (ø8)	ø0.236" (ø6)	KFG2L0906-00	12	14	18.7	6.6	5.3	17	28
ø3/8" (ø9.53)	ø1/4" (ø6.35)	KFG2L1163-00	15	17	22.2	7.6	5.6	19	50
ø1/2" (ø12.7)	ø3/8" (ø9.53)	KFG2L1395-00	17	19	24.8	8.5	8.5	51	62

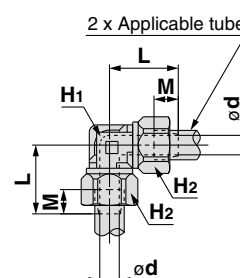

Dimensions

Swivel Elbow: KFG2V



Applicable tube size (inch)		Connection thread NPT	Model	Width across flat			L1	L2	M	ød	A*	Effective area (mm ²)	Weight (g)				
O.D.	I.D.			H1	H2	H3											
ø1/8" (ø3.18)	ø0.086" (ø2.18)	1/8	KFG2V0122-N01	7	8	12	14.5	16.1	5	1.5	17.3	1	11				
		1/4	KFG2V0122-N02			14								19.8			
ø5/32" (ø4)	ø0.098" (ø2.5)	1/8	KFG2V0325-N01	7	8	12	14.5	16.1	5	1.8	17.3	1.4	11				
			1/4			KFG2V0325-N02								14	19.8		
ø1/4" (ø6.35)	ø5/32" (ø3.95)	1/8	KFG2V0704-N01	10	12	12	16.2	18.3	6	3.3	21.7	5	16				
			1/4			KFG2V0704-N02								14	22	24.2	25
ø5/16" (ø8)	ø0.236" (ø6)	1/8	KFG2V0906-N01	12	14	12	18.4	19.6	6.6	5.3	24.1	14	23				
			1/4			KFG2V0906-N02								14	23.3	26.6	31
			3/8			KFG2V0906-N03								19	25.1	28.1	45
ø3/8" (ø9.53)	ø1/4" (ø6.35)	1/4	KFG2V1163-N02	15	17	14	21.4	24.7	7.6	5.6	29.7	16	38				
			3/8			KFG2V1163-N03								19	26.8	31.4	51
			KFG2V1163-N04			22		30.6			33.5		75				
		ø1/2" (ø12.7)	ø3/8" (ø9.53)	1/4	KFG2V1395-N02	17	19	14	23	8.5	8.5	31.8	43	46			
	3/8			KFG2V1395-N03	19			27.8							33.5	59	
			KFG2V1395-N04			22		31.6			35.6		83				

* Reference dimensions after installation of NPT thread

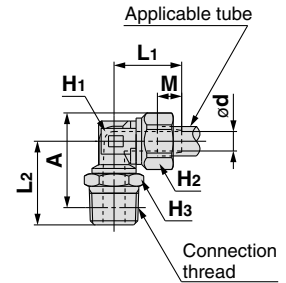

Female Connector: KFG2F



Applicable tube size (inch)		Connection thread NPT	Model	Width across flat		L1	L2	M	ød	Effective area (mm ²)	Weight (g)
O.D.	I.D.			H1	H2						
ø1/8" (ø3.18)	ø0.086" (ø2.18)	1/4	KFG2F0122-N02	17	8	26.7	17.2	5	1.5	1.1	25
ø5/32" (ø4)	ø0.098" (ø2.5)	1/4	KFG2F0325-N02	17	8	26.7	17.2	5	1.8	1.6	23
ø1/4" (ø6.35)	ø5/32" (ø3.95)	1/4	KFG2F0704-N02	17	12	27.5	16.3	6	3.3	6	28
ø5/16" (ø8)	ø0.236" (ø6)	3/8	KFG2F0906-N03	19	14	29.4	17	6.6	5.3	17	32
ø3/8" (ø9.53)	ø1/4" (ø6.35)	3/8	KFG2F1163-N03	19	17	30.5	16.1	7.6	5.6	19	38
ø1/2" (ø12.7)	ø3/8" (ø9.53)	3/8	KFG2F1395-N03	19	19	31.6	15.6	8.5	8.5	51	42

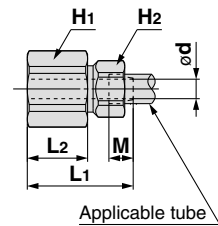

Union Nut: KFG2N



Applicable tube O.D. (inch)	Model	H (Width across flat)	L	Weight (g)
ø1/8" (ø3.18)	KFG2N-01	8	7.8	1.9
ø5/32" (ø4)	KFG2N-03	8	7.7	1.9
ø1/4" (ø6.35)	KFG2N-07	12	9	4.6
ø5/16" (ø8)	KFG2N-09	14	10.1	6.7
ø3/8" (ø9.53)	KFG2N-11	17	11.7	10.7
ø1/2" (ø12.7)	KFG2N-13	19	12.8	13

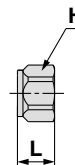

Metric Size **KQG2**

Inch Size **KQG2**

Specific Product Precautions **KQG2**

Metric Size **KFG2**

Inch Size **KFG2**

Specific Product Precautions **KFG2**

Applicable Fluid List



Series KFG2

Specific Product Precautions 1

Be sure to read before handling. Refer to back cover for Safety Instructions, "Handling Precautions for SMC Products" (M-E03-3) for Fittings and Tubing Precautions.

Selection

⚠ Caution

1. Consult with SMC regarding fluids other than air, water and steam.
2. When using the swivel elbow fittings, particles may be generated by rotation for positioning after connecting. If you are concerned about the effects on machinery and equipment, check the particle generation with your machine before use.

Mounting

⚠ Caution

1. The swivel elbow fittings can be rotated for positioning, but they cannot be used rotating.
This will cause metal debris by wearing, which may enter the operating fluid or cause fitting damage.
2. Keep the connection part of fittings and tubes from rotating or oscillating movement.

Piping

⚠ Caution

1. Take a tube having no flaws on its periphery and cut it off at right angles.
(Use a tube cutter TK-1, 2, 3. Do not use pinchers, nippers or scissors, etc.)
The tube might be cut diagonally or flattened, making installation impossible or causing problems such as disconnection and leakage.
2. Insert the tube into the union nut with the union nut removed. Grab the tube and gently push it thoroughly into the fitting.

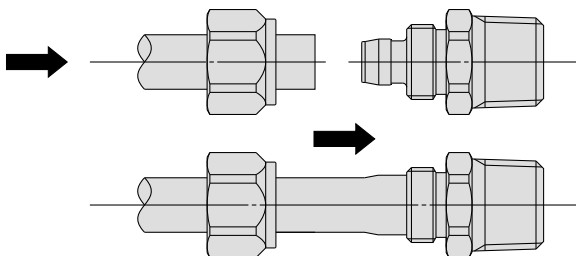

3. After insertion, tighten the union nut temporarily by hand.

Piping

⚠ Caution

4. Fix the body with a tightening tool. Tighten the union nut to the end surface of the body using a suitable wrench.

Hex. across flats may be deformed, if using an improper wrench for hex. across flats. Tighten the union nut with the proper tightening torque shown below.

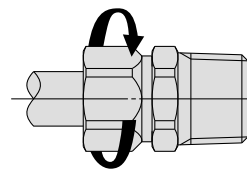

Fitting size	Proper tightening torque N·m
KFG2□01	2 to 3
KFG2□03	
KFG2□04	
KFG2□06	3 to 4
KFG2□07	
KFG2□08	5 to 6
KFG2□09	
KFG2□10	8 to 10
KFG2□11	
KFG2□12	10 to 12
KFG2□13	
KFG2□16	16 to 18

Operating Environment

⚠ Warning

1. Avoid installing and using fittings inside a food zone.

Not installable

Food zone An environment where food which will be sold as merchandise, directly touches the fitting components.

Installable

Splash zone An environment where food which will not be sold as merchandise, directly touches the fitting components.

Non-food zone An environment where there is no contact with food.

Maintenance

⚠ Caution

1. Pre-maintenance inspection

When the product is removed, turn off the power, cut off the supply pressure, and confirm that fluid in the piping has been discharged.

2. During regular maintenance, check for the following and replace any components as necessary.

- a) Scratches, gouges, abrasion, corrosion
- b) Leakage
- c) Flattening or distortion of the tube
- d) Hardening, deterioration or softness of the tube
- e) Loosening of the union nut

3. Do not repair the fittings or patch the tube for reuse.



Series KFG2

Specific Product Precautions 2

Be sure to read before handling. Refer to back cover for Safety Instructions, “Handling Precautions for SMC Products” (M-E03-3) for Fittings and Tubing Precautions.

Maintenance

⚠ Caution

4. After operation at a high temperature, leakage may occur due to time dependent change of the tube material. If leakage occurs, remove the tube, cut off the connecting part of the tube, and connect to the piping again.

Check if the tube dimension accuracy is within the recommended tolerance. If it is difficult to take the tube out of the body, bend the tube to the side to remove.

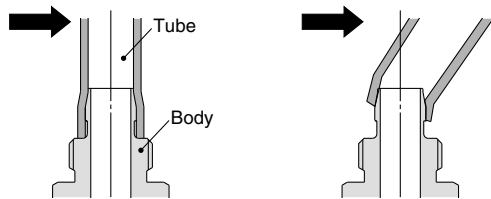

Stainless steel

Metal exists in nature as ore (like oxide or sulfide). This means that oxide or sulfide is more stable than pure metal. Accordingly, metallic material chemically oxidizes (metallic constituent becomes ion and melts out). It corrodes in the natural environment.

Even though corrosion of metal easily occurs in an environment where oxidizing tendency is stronger, some kinds of metal have a characteristic for which corrosion never happens if the level of oxidizing goes higher than a specific point. In such a case, it is called “metal in passive state”.

Stainless steel has corrosion resistance because of a thin coat of passive state on its surface. However, there does not exist stainless steel with absolute corrosion resistance; therefore, many types of stainless steel have been developed for improved corrosion resistance performance.

Metric Size **KQG2**

Inch Size **KQG2**

Specific Product Precautions **KQG2**

Metric Size **KFG2**

Inch Size **KFG2**

Specific Product Precautions **KFG2**

Applicable Fluid List



Series KQG2/KFG2

Applicable Fluid List

How to Read the Table

- ◎: Completely unaffected or largely unaffected.
- : May be slightly affected, but, dependent upon condition, can sufficiently withstand.
- △: Advisable to use as little as possible.
- ×: Not applicable, as substantially affected.
- : No data is available.

Compatibility Checklist for Used Materials and Fluids

Chemical	Body	Seal
	Stainless steel 316	Special FKM
Acrylonitrile	◎	×
Acetamide	○	○
Acetaldehyde	◎	×
Acetone	◎	×
Aniline	○	◎
Amylene	◎	—
Sulphurous acid gas (Humid gas)	◎	—
Sodium bisulfite [50%]	◎	—
Allyl alcohol	◎	—
Benzoic acid	◎	—
Ammonia (Compressed gas)	◎	×
Isopropyl alcohol	○	◎
Isophorone	×	—
Ethyl alcohol	◎	○
Ethyl ether	○	×
Ethylene	◎	—
Ethylene glycol	○	◎
Ethylene diamine	◎	—
Ethylene dichloride	◎	—
Epichlorohydrine	◎	×
Methyl tertiary butyl ether	—	×
Allyl chloride	×	—
Ammonium chloride	◎	—
Calcium chloride	◎	—
Iron(II) chloride [5%]	×	—
Sodium chloride	○	—
Magnesium chloride	◎	—
Hydrochloric acid [5%]	×	—
Chlorine gas (Humid gas)	×	—
Carbitol	×	—
Formic acid [50%]	○	×
o-Xylene	△	△
p-Xylene	△	△
Citric acid	◎	—
Cumene	×	—
Glycerin	◎	◎
Cresol	◎	△

Chemical	Body	Seal
	Stainless steel 316	Special FKM
Chromic acid [10%]	◎	—
Chlorosulfonic acid	○	×
Chlorofluorocarbon (CFC) 11	—	×
Chlorofluorocarbon (CFC) 113	—	×
Chlorofluorocarbon (CFC) 12	○	×
Chlorofluorocarbon (CFC) 13B1	—	×
Chlorofluorocarbon (CFC) 14	—	◎
Chlorofluorocarbon (CFC) 22	○	×
Chlorobenzene	×	○
Chloroform (Trichloromethane)	○	○
Acetic acid	○	×
Amyl acetate	◎	×
Isopropyl acetate [20%]	◎	×
Ethyl acetate	×	×
Butyl acetate	×	×
Methyl acetate	◎	×
Calcium hypochlorite	◎	—
Sodium hypochlorite [5%]	◎	◎
Potassium cyanide [50%]	◎	—
Copper cyanide	◎	—
Diisobutyl ketone	◎	—
Diisobutylene	—	◎
Diethanolamine	◎	—
Diethylamine	×	×
Diethylene glycol	◎	—
Carbon tetrachloride	◎	◎
Cyclohexanol	×	—
Cyclohexanone	×	×
Cyclohexane	×	○
Dichloroethylene	—	△
Dichlorobenzene	—	△
Dichloromethane (Methylene chloride)	△	△
Ethylene bromide	×	—
Potassium bromide [30%]	◎	—
Potassium dichromate [25%]	◎	—
Oxalic acid	◎	—
Bromine gas	×	—

Applicable Fluid List

Chemical	Body	Seal
	Stainless steel 316	Special FKM
Tartaric acid	◎	—
Nitric acid [65%]	◎	◎
Ammonium nitrate	◎	—
Ammonium hydroxide	—	○
Calcium hydroxide	◎	—
Sodium hydroxide [50%]	◎	○
Barium hydroxide	◎	—
Solvent naphtha	◎	—
Carbonic acid (Humid gas and aqueous solution)	◎	—
Tetrachloroethylene	×	◎
Tetrahydrofuran	—	×
Dodecylbenzene	◎	—
Trichloroethane	△	—
Trichloroethylene	◎	○
Trichloroacetic acid	—	—
Toluene	◎	◎
Naphtha	○	○
Naphthenic acid	◎	—
Lactic acid	◎	—
Carbon disulfide	○	◎
Picric acid	◎	—
Pyridine	×	×
Phenol	×	○
Butyl phthalate	×	—
Butyl alcohol	△	—
Hydrofluoric acid [50%]	◎	—
Furfurol	×	×
n-Propyl alcohol	◎	—
Propylene glycol	◎	—
Bromochloroethane	—	×
n-Hexane	○	◎
n-Hexyl alcohol	◎	—
n-Heptane	◎	—
Benzene	×	×
n-Pentane	×	—
Boric acid	◎	—
Gallic acid	◎	—

Chemical	Body	Seal
	Stainless steel 316	Special FKM
Formic aldehyde	◎	×
Methyl methacrylate	×	×
Methyl alcohol	◎	○
Methyl isobutyl ketone	×	×
Methyl ethyl ketone	×	×
Ethyleneglycol monomethyl ether	×	—
Monoethanolamine	◎	—
Morpholine	◎	—
Butyric acid	◎	—
Hydrogen sulfide (Humid gas and aqueous solution)	◎	×
Sulphuric acid [10%]	◎	◎
Ammonium sulfate	◎	×
Sodium bisulfate [10%]	◎	—
Iron(II) sulfate	○	—
Sodium sulfate	◎	—
Phosphoric acid [85%]	◎	—

Note 1) [] denotes the concentration. Aqueous solutions without condensation notes are in a saturated state.

Note 2) The above data is based on a room temperature of 20°C. Note that you may obtain different figures, depending on temperature conditions.

Note 3) The above data shows compatibility guidelines based upon component parts. Therefore, it is no guarantee of product performance. In addition, using fluids other than those specified in the catalog are not covered by the product's warranty.

Metric Size **KQG2**

Inch Size **KQG2**

Specific Product Precautions **KQG2**

Metric Size **KFG2**

Inch Size **KFG2**

Specific Product Precautions **KFG2**

Applicable Fluid List

Safety Instructions

These safety instructions are intended to prevent hazardous situations and/or equipment damage. These instructions indicate the level of potential hazard with the labels of “**Caution**,” “**Warning**” or “**Danger**.” They are all important notes for safety and must be followed in addition to International Standards (ISO/IEC)*1, and other safety regulations.



Caution:

Caution indicates a hazard with a low level of risk which, if not avoided, could result in minor or moderate injury.



Warning:

Warning indicates a hazard with a medium level of risk which, if not avoided, could result in death or serious injury.



Danger:

Danger indicates a hazard with a high level of risk which, if not avoided, will result in death or serious injury.

- *1) ISO 4414: Pneumatic fluid power – General rules relating to systems.
ISO 4413: Hydraulic fluid power – General rules relating to systems.
IEC 60204-1: Safety of machinery – Electrical equipment of machines.
(Part 1: General requirements)
ISO 10218-1: Manipulating industrial robots - Safety.
etc.



Warning

1. The compatibility of the product is the responsibility of the person who designs the equipment or decides its specifications.

Since the product specified here is used under various operating conditions, its compatibility with specific equipment must be decided by the person who designs the equipment or decides its specifications based on necessary analysis and test results. The expected performance and safety assurance of the equipment will be the responsibility of the person who has determined its compatibility with the product. This person should also continuously review all specifications of the product referring to its latest catalogue information, with a view to giving due consideration to any possibility of equipment failure when configuring the equipment.

2. Only personnel with appropriate training should operate machinery and equipment.

The product specified here may become unsafe if handled incorrectly. The assembly, operation and maintenance of machines or equipment including our products must be performed by an operator who is appropriately trained and experienced.

3. Do not service or attempt to remove product and machinery/equipment until safety is confirmed.

- The inspection and maintenance of machinery/equipment should only be performed after measures to prevent falling or runaway of the driven objects have been confirmed.
- When the product is to be removed, confirm that the safety measures as mentioned above are implemented and the power from any appropriate source is cut, and read and understand the specific product precautions of all relevant products carefully.
- Before machinery/equipment is restarted, take measures to prevent unexpected operation and malfunction.

4. Contact SMC beforehand and take special consideration of safety measures if the product is to be used in any of the following conditions.

- Conditions and environments outside of the given specifications, or use outdoors or in a place exposed to direct sunlight.
- Installation on equipment in conjunction with atomic energy, railways, air navigation, space, shipping, vehicles, military, medical treatment, combustion and recreation, or equipment in contact with food and beverages, emergency stop circuits, clutch and brake circuits in press applications, safety equipment or other applications unsuitable for the standard specifications described in the product catalogue.
- An application which could have negative effects on people, property, or animals requiring special safety analysis.
- Use in an interlock circuit, which requires the provision of double interlock for possible failure by using a mechanical protective function, and periodical checks to confirm proper operation.



Caution

1. The product is provided for use in manufacturing industries.

The product herein described is basically provided for peaceful use in manufacturing industries.

If considering using the product in other industries, consult SMC beforehand and exchange specifications or a contract if necessary.

If anything is unclear, contact your nearest sales branch.

Limited warranty and Disclaimer/ Compliance Requirements

The product used is subject to the following “Limited warranty and Disclaimer” and “Compliance Requirements”.

Read and accept them before using the product.

Limited warranty and Disclaimer

- The warranty period of the product is 1 year in service or 1.5 years after the product is delivered.*2)
Also, the product may have specified durability, running distance or replacement parts. Please consult your nearest sales branch.
- For any failure or damage reported within the warranty period which is clearly our responsibility, a replacement product or necessary parts will be provided.
This limited warranty applies only to our product independently, and not to any other damage incurred due to the failure of the product.
- Prior to using SMC products, please read and understand the warranty terms and disclaimers noted in the specified catalogue for the particular products.

*2) Vacuum pads are excluded from this 1 year warranty.

A vacuum pad is a consumable part, so it is warranted for a year after it is delivered. Also, even within the warranty period, the wear of a product due to the use of the vacuum pad or failure due to the deterioration of rubber material are not covered by the limited warranty.

Compliance Requirements

- The use of SMC products with production equipment for the manufacture of weapons of mass destruction (WMD) or any other weapon is strictly prohibited.
- The exports of SMC products or technology from one country to another are governed by the relevant security laws and regulations of the countries involved in the transaction. Prior to the shipment of a SMC product to another country, assure that all local rules governing that export are known and followed.



Safety Instructions

Be sure to read “Handling Precautions for SMC Products” (M-E03-3) before using.

SMC Corporation (Europe)

Austria	+43 2262622800	www.smc.at	office@smc.at	Lithuania	+370 5 2308118	www.smclt.lt	info@smclt.lt
Belgium	+32 (0)33551464	www.smcpn pneumatics.be	info@smcpn pneumatics.be	Netherlands	+31 (0)205318888	www.smcpn pneumatics.nl	info@smcpn pneumatics.nl
Bulgaria	+359 29744492	www.smc.bg	office@smc.bg	Norway	+47 67129020	www.smc-norge.no	post@smc-norge.no
Croatia	+385 13776674	www.smc.hr	office@smc.hr	Poland	+48 222119600	www.smc.pl	office@smc.pl
Czech Republic	+420 541424611	www.smc.cz	office@smc.cz	Portugal	+351 226166570	www.smc.eu	postpt@smc.smces.es
Denmark	+45 70252900	www.smc.dk.com	smc@smcdk.com	Romania	+40 213205111	www.smcromania.ro	post@smcpn pneumatics.ro
Estonia	+372 6510370	www.smcpn pneumatics.ee	smc@smcpn pneumatics.ee	Russia	+7 8127185445	www.smc-pneumatik.ru	info@smc-pneumatik.ru
Finland	+358 207513513	www.smc.fi	smcfin@smc.fi	Slovakia	+421 413213212	www.smc.sk	office@smc.sk
France	+33 (0)164761000	www.smc-france.fr	contact@smc-france.fr	Slovenia	+386 73885412	www.smc.si	office@smc.si
Germany	+49 (0)61034020	www.smc-pneumatik.de	info@smc-pneumatik.de	Spain	+34 945184100	www.smc.eu	post@smc.smces.es
Greece	+30 210 2717265	www.smchellas.gr	sales@smchellas.gr	Sweden	+46 (0)86031200	www.smc.nu	post@smcpn pneumatics.se
Hungary	+36 23511390	www.smc.hu	office@smc.hu	Switzerland	+41 (0)523963131	www.smc.ch	info@smc.ch
Ireland	+353 (0)14039000	www.smcpn pneumatics.ie	sales@smcpn pneumatics.ie	Turkey	+90 (0)2124440762	www.entek.com.tr	smc@entek.com.tr
Italy	+39 (0)292711	www.smccitalia.it	mailbox@smccitalia.it	UK	+44 (0)845 121 5122	www.smcpn pneumatics.co.uk	sales@smcpn pneumatics.co.uk
Latvia	+371 67817700	www.smc.lv	info@smclv.lv				