

Compact Cylinder with Linear Guide

Ø 12, Ø 16, Ø 20, Ø 25

New

RoHS

Compact

49.5 mm Overall length

MXZ Ø 20, 10 mm stroke

30 mm Width

MXZ Ø 20



- Design and assembly time is reduced due to integration of a linear guide to the cylinder.
- Lightweight workpieces such as electronic boards can be stopped, positioned and clamped.



MXZ Series

SMC

CAT.EUS20-236A-UK

Compact Cylinder with Linear Guide *MXZ Series*

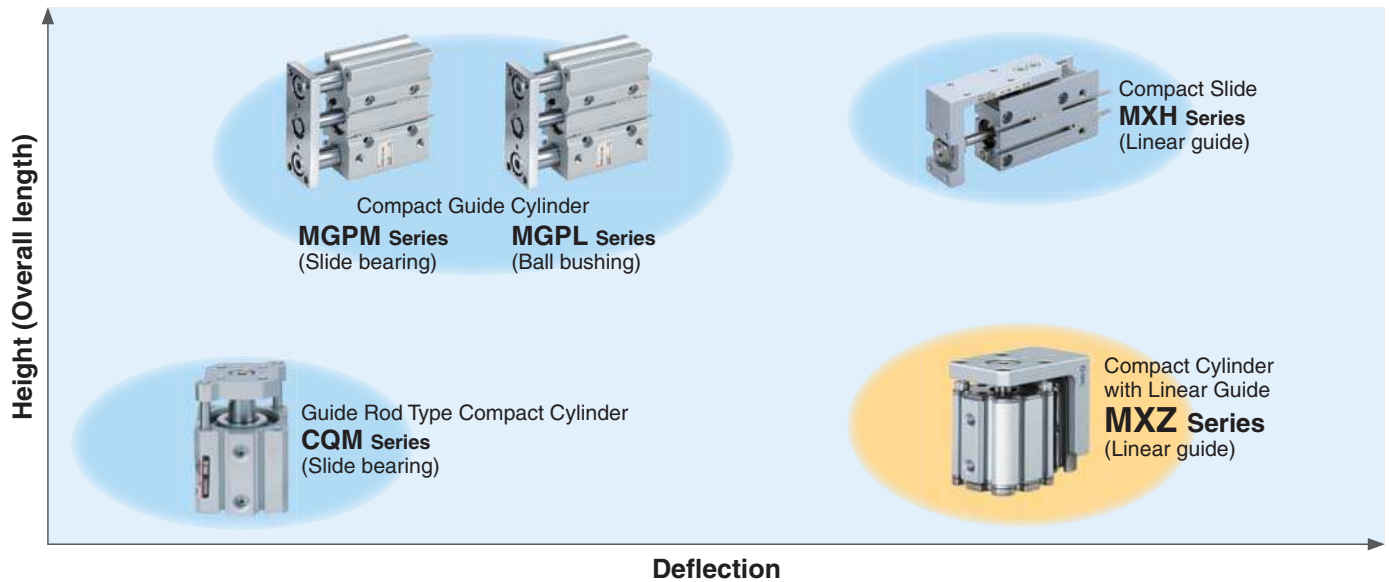

Compact and Space-saving

Height/at 10 mm stroke [mm]

Bore size	MXZ	MXH	MGP	CQM
12	44	56.5*1	53	41.5
16	45	66	59	41.5
20	49.5	78	69	52
25	54	—	75.5	55.5

*1 Compared with bore size of Ø 10

Width [mm]

Bore size	MXZ	MXH	MGP	CQM
12	23	20*1	26	25
16	26	25	30	29
20	30	32	36	36
25	33.5	—	42	40

*1 Compared with bore size of Ø 10

Depth [mm]

Bore size	MXZ	MXH	MGP	CQM
12	37.4	47*1	58	25
16	40.9	53.5	64	29
20	49.4	64.5	83	36
25	57.4	—	93	40

*1 Compared with bore size of Ø 10

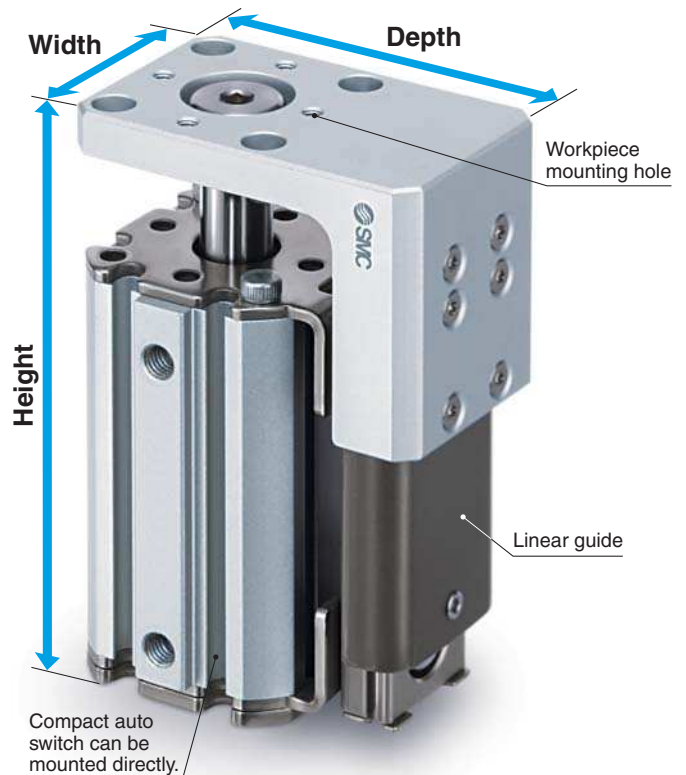

Mounting

Through-hole mounting

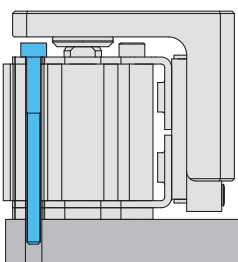

Tap mounting

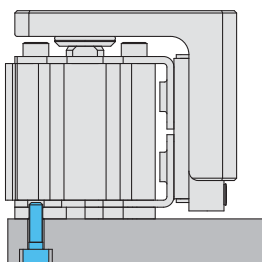

Port Location Selectable

Ex.) **MXZ20 R -30-M9BW**

Pilot port location

—	Front
R	Right
L	Left

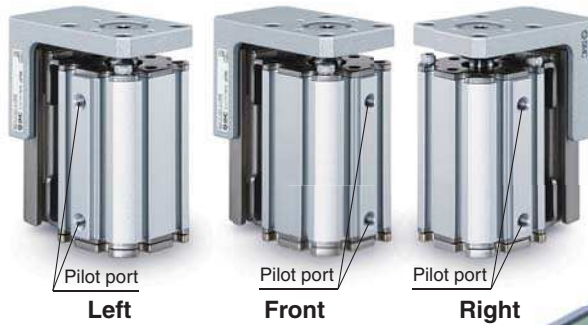

Auto Switch Mountable on 3 Surfaces

(For $\varnothing 20$, $\varnothing 25$)

· Solid state auto switch: D-M9□



Application Examples

Lightweight workpieces such as electronic boards can be stopped, positioned and clamped with high accuracy.

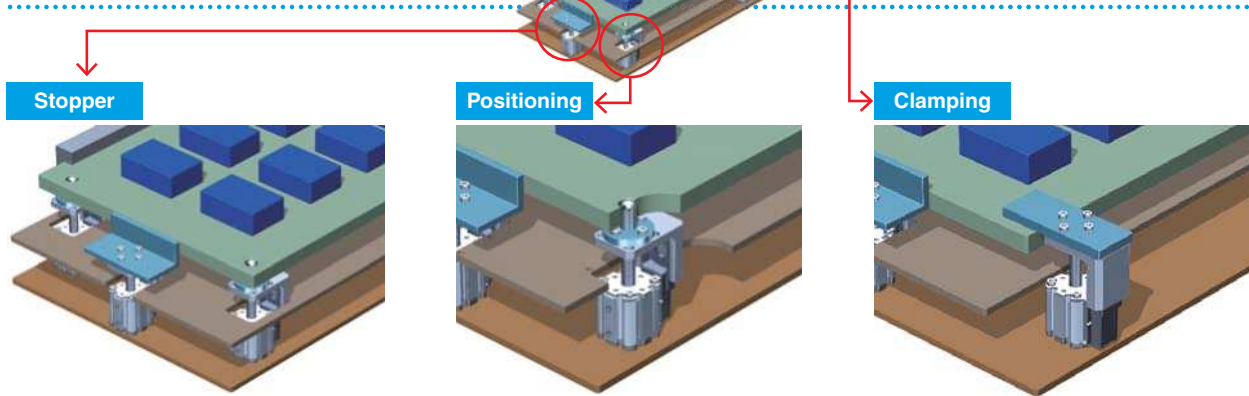

Lifter

Space is reduced due to the integrated construction of a cylinder and linear guide.

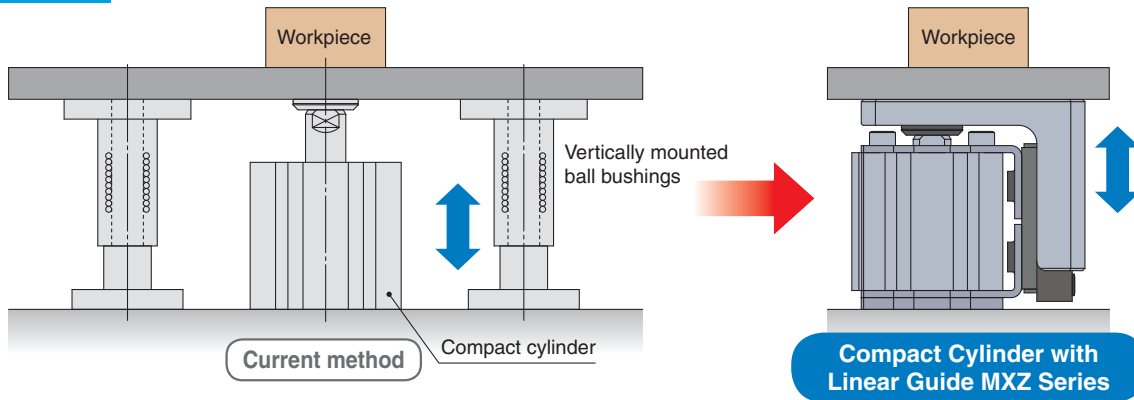

Variations

Series	Bore size [mm]	Standard stroke [mm]										Option
		5	10	15	20	25	30	35	40	45	50	
MXZ	12	●	●	●	●	●	●	—	—	—	—	Pilot location selectable
	16	●	●	●	●	●	●	—	—	—	—	
	20	●	●	●	●	●	●	●	●	●	●	
	25	●	●	●	●	●	●	●	●	●	●	

CONTENTS

How to Order.....	Page 3	MXZ20.....	Page 9
Specifications.....	Page 4	MXZ25.....	Page 10
Dimensions		Model Selection.....	Page 11
MXZ12.....	Page 7	Auto Switch Mounting.....	Page 15
MXZ16.....	Page 8		

Compact Cylinder with Linear Guide

MXZ Series

∅ 12, ∅ 16, ∅ 20, ∅ 25





How to Order

MXZ 20 - 20 - M9BW

Bore size

12	12 mm
16	16 mm
20	20 mm
25	25 mm

Pilot port location

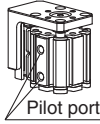
—	Front 
R	Right 
L	Left 

Number of auto switches

—	2
S	1
n	n

* The number of auto switches that can be mounted depends on the bore size and the port location of the product. ▶ P. 16

Auto switch

—	Without auto switch (Built-in magnet)
---	---------------------------------------

* For applicable auto switches, refer to the table below.

Option

—	Without mounting bolt
L	With mounting bolt

* 2 mounting bolts are shipped together with the product, (but not assembled).
* Details of the mounting bolt ▶ P. 6

Stroke/Minimum stroke for auto switch mounting ▶ P. 15

Bore size	Standard stroke [mm]									
	5	10	15	20	25	30	35	40	45	50
12	●	●	●	●	●	●	—	—	—	—
16	●	●	●	●	●	●	—	—	—	—
20	●	●	●	●	●	●	●	●	●	●
25	●	●	●	●	●	●	●	●	●	●

Applicable Auto Switches/Refer to the Auto Switch Guide for further information.

Type	Special function	Electrical entry	Indicator light	Wiring (Output)	Load voltage		Auto switch model		Lead wire length [m]				Pre-wired connector	Applicable load	
					DC	AC	Perpendicular	In-line	0.5 (—)	1 (M)	3 (L)	5 (Z)			
Solid state auto switch	—	Grommet	Yes	3-wire (NPN)	24 V	—	M9NV	M9N	●	●	●	○	○	Relay, PLC	IC circuit
				3-wire (PNP)			M9PV	M9P	●	●	●	○	○		—
				2-wire			M9BV	M9B	●	●	●	○	○		—
				3-wire (NPN)			M9NWV	M9NW	●	●	●	○	○		IC circuit
	Diagnostic indication (2-colour indicator)			3-wire (PNP)	M9PWV	M9PW	●	●	●	○	○	○	—		
				2-wire	M9BWV	M9BW	●	●	●	○	○	—			
				3-wire (NPN)	M9NAV*1	M9NA*1	○	○	●	○	○	○	IC circuit		
				3-wire (PNP)	M9PAV*1	M9PA*1	○	○	●	○	○	○	—		
				Water resistant (2-colour indicator)	2-wire	M9BAV*1	M9BA*1	○	○	●	○	○	○		—

*1 Water resistant type auto switches are mountable on the above models, but SMC cannot guarantee water resistance. Please contact SMC for water resistant products.

* Lead wire length symbols: 0.5 m — (Example) M9NW
 1 m M (Example) M9NWM
 3 m L (Example) M9NWL
 5 m Z (Example) M9NWZ

* Solid state auto switches marked with "○" are produced upon receipt of order.

* There are other applicable auto switches than listed above. Details ▶ P. 16

* Auto switches are shipped together, but not assembled.



Specifications

Bore size [mm]	12	16	20	25
Pilot port	M3 x 0.5		M5 x 0.8	
Fluid	Air			
Action	Double acting			
Operating pressure	0.1 to 0.7 MPa			
Proof pressure	1.05 MPa			
Ambient and fluid temperature	5 to 60°C			
Piston speed (Average speed)	50 to 500 mm/s			
Cushion	Rubber bumper			
Lubrication	Non-lube			
Auto switch	Solid state auto switch (2-wire, 3-wire) 2-colour indicator solid state auto switch (2-wire, 3-wire)			
Stroke length tolerance	+1.3 to 0 mm (when pressure is not applied)			

* Stroke length tolerance does not include the amount of bumper change.

Theoretical Output

Bore size [mm]	Rod size [mm]	Operating direction	Piston area [mm ²]	Operating pressure [MPa]					
				0.2	0.3	0.4	0.5	0.6	0.7
12	6	OUT	113	23	34	45	57	68	79
		IN	85	17	25	34	42	51	59
16	8	OUT	201	40	60	80	101	121	141
		IN	151	30	45	60	75	90	106
20	10	OUT	314	63	94	126	157	188	220
		IN	236	47	71	94	118	141	165
25	12	OUT	491	98	147	196	245	295	344
		IN	378	76	113	151	189	227	264

Cylinders with auto switches ▶ **P. 15, 16**

- Minimum Stroke for Auto Switch Mounting
- Auto Switch Proper Mounting Position
- Auto Switch Mounting Height
- Operating Range
- Auto Switch Mounting Groove Position
- Auto Switch Mounting

Weight

Bore size [mm]	Standard stroke [mm]									
	5	10	15	20	25	30	35	40	45	50
12	105	114	124	132	142	152	—	—	—	—
16	126	136	146	156	166	175	—	—	—	—
20	195	211	225	239	255	270	285	300	314	329
25	284	304	324	343	363	384	403	423	442	462

MXZ Series

Maximum Load / Allowable Kinetic Energy

Bore size [mm]	Maximum load [kg]	Allowable kinetic energy [J]
12	1.2	0.022
16	2	0.038
20	3	0.055
25	5	0.09

$$\text{Kinetic energy } E \text{ [J]} = \frac{(m1 + m2) V^2}{2}$$

m1: Cylinder's moving parts weight kg

m2: Load weight kg

V: Piston speed at the end m/s

* The piston speed when the piston (rod) of a cylinder is reached at the stroke end is calculated by multiplying the average speed by 1.4

Moving Parts Weight

Bore size [mm]	Standard stroke [mm]									
	5	10	15	20	25	30	35	40	45	50
12	34	36	38	41	43	46	—	—	—	—
16	39	42	44	46	49	51	—	—	—	—
20	67	70	75	79	83	88	92	97	101	105
25	103	110	116	123	130	137	143	150	157	164

Accuracy

End deflection (Y direction)*1	±0.02 mm
End deflection (X direction)*1	±0.02 mm
Non-rotating accuracy*1	±0.05°

*1 The values show the end deflection or "play" of the product without load in the extended condition. This does not include the product deflection.

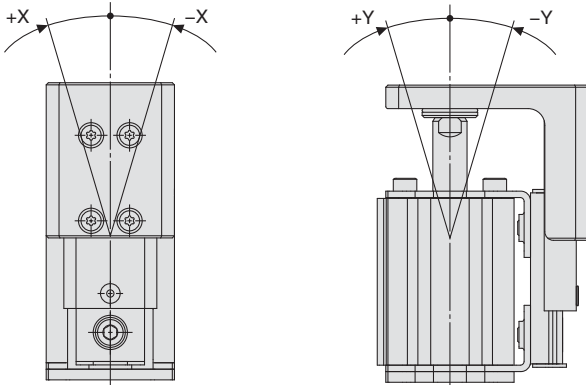

**End deflection
(when extended)**

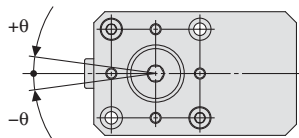

Non-rotating accuracy

Mounting Bolt

When using through holes, use the mounting bolts from the CQ series. Refer to the following for ordering procedures. Order the actual number of bolts that will be used.

Example) CQ-M3 x 25 L 2 pcs.

Material: Chromium molybdenum steel
Surface treatment: Zinc chromated

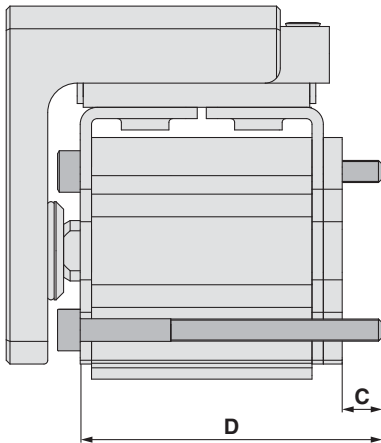

Mounting Bolt for MXZ

Bore size [mm]	Stroke	C	D	Mounting bolt part no.
12	5	5.6	35	CQ-M3 x 35 L
	10		40	CQ-M3 x 40 L
	15		45	CQ-M3 x 45 L
	20		50	CQ-M3 x 50 L
	25		55	CQ-M3 x 55 L
	30		60	CQ-M3 x 60 L
16	5	4.6	35	CQ-M3 x 35 L
	10		40	CQ-M3 x 40 L
	15		45	CQ-M3 x 45 L
	20		50	CQ-M3 x 50 L
	25		55	CQ-M3 x 55 L
	30		60	CQ-M3 x 60 L
20	5	5.5	40	CQ-M3 x 40 L
	10		45	CQ-M3 x 45 L
	15		50	CQ-M3 x 50 L
	20		55	CQ-M3 x 55 L
	25		60	CQ-M3 x 60 L
	30		65	CQ-M3 x 65 L
	35		70	CQ-M3 x 70 L
	40		75	CQ-M3 x 75 L
	45		80	CQ-M3 x 80 L
	50		85	CQ-M3 x 85 L
25	5	8	45	CQ-M3 x 45 L
	10		50	CQ-M3 x 50 L
	15		55	CQ-M3 x 55 L
	20		60	CQ-M3 x 60 L
	25		65	CQ-M3 x 65 L
	30		70	CQ-M3 x 70 L
	35		75	CQ-M3 x 75 L
	40		80	CQ-M3 x 80 L
	45		85	CQ-M3 x 85 L
	50		90	CQ-M3 x 90 L

MXZ Series

Dimensions: MXZ12

MXZ12-□ Standard (Pilot port location: Front)

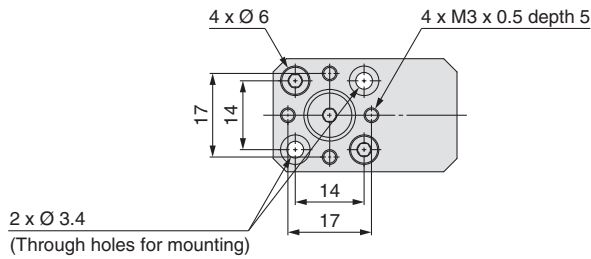
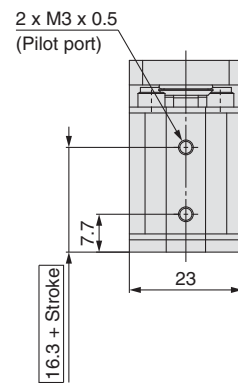
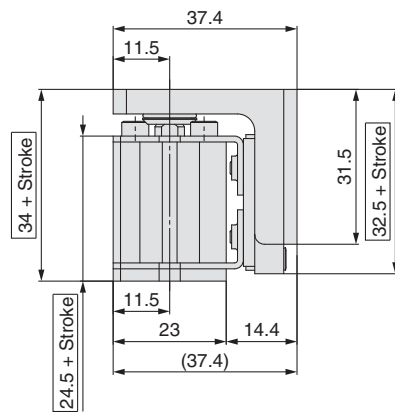
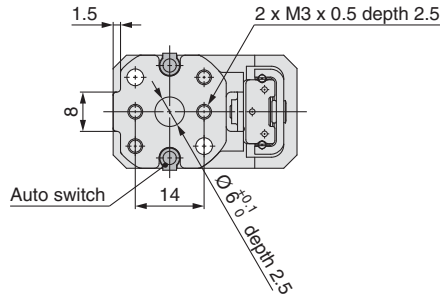

MXZ12L-□ (Pilot port location: Left)

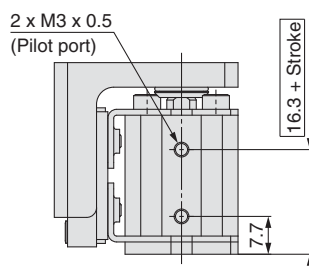
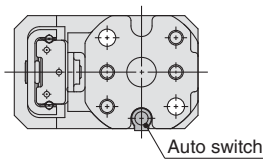

MXZ12R-□ (Pilot port location: Right)

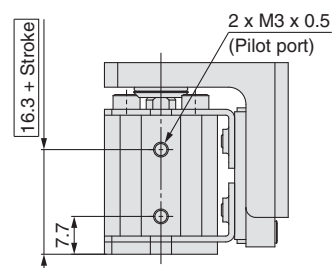
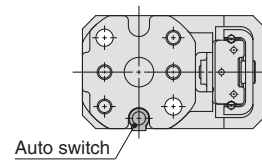



Dimensions: MXZ16

MXZ16-□ Standard (Pilot port location: Front)

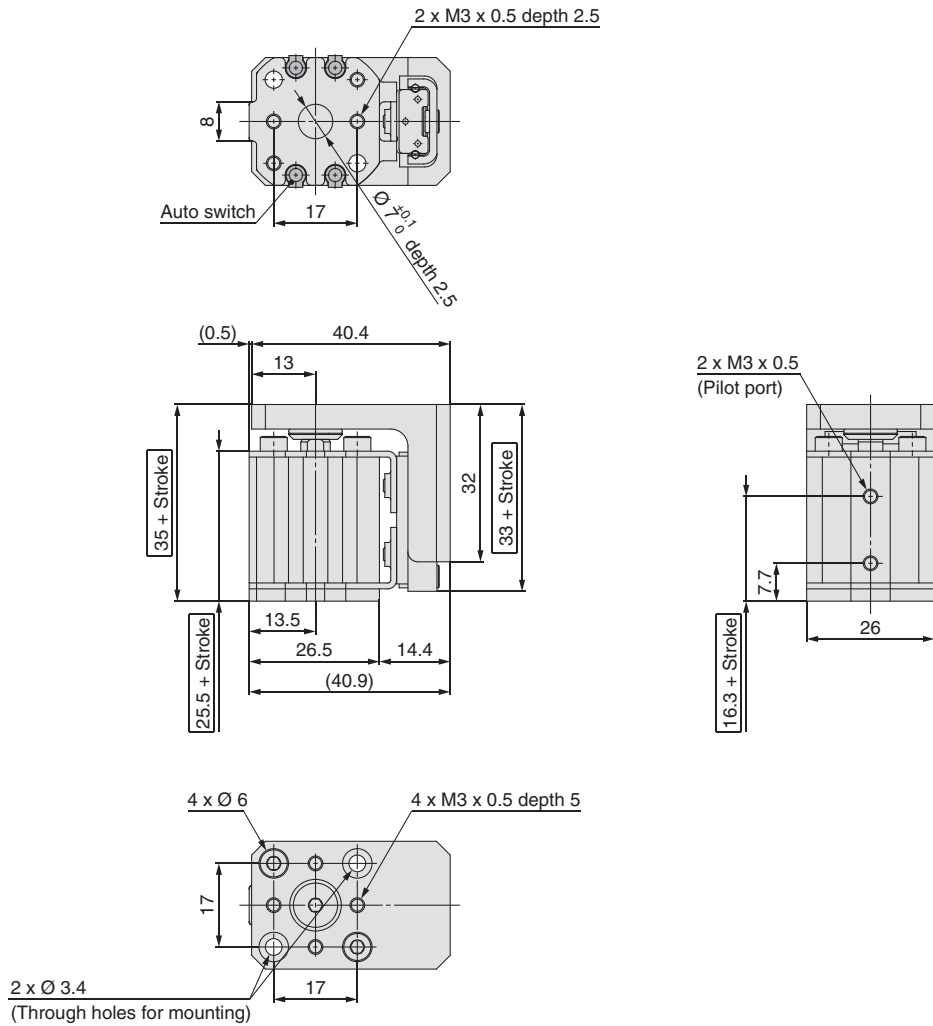

MXZ16L-□ (Pilot port location: Left)

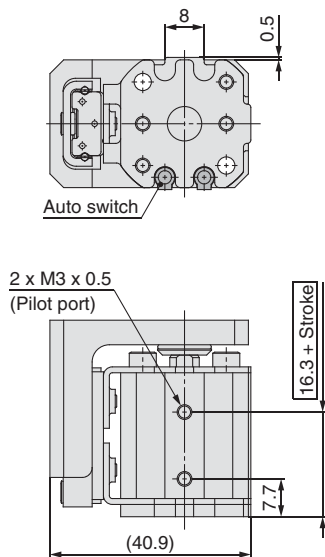

MXZ16R-□ (Pilot port location: Right)

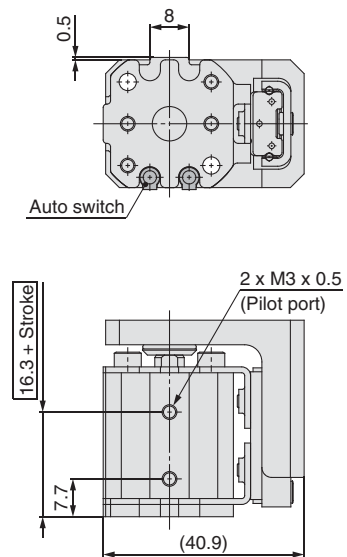

MXZ Series

Dimensions: MXZ20

MXZ20-□ Standard (Pilot port location: Front)

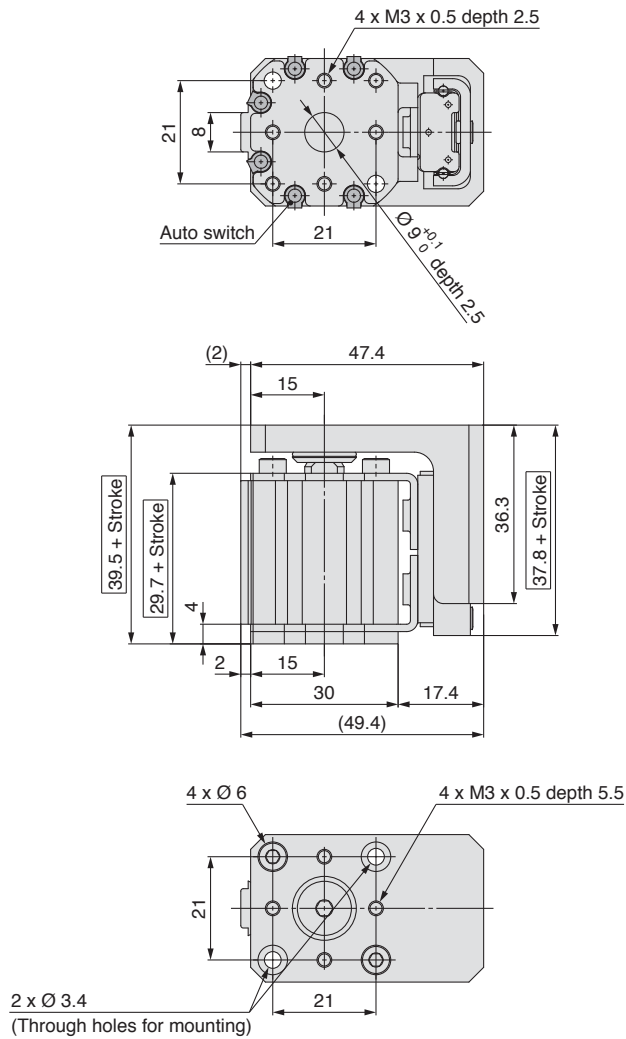

MXZ20L-□ (Pilot port location: Left)

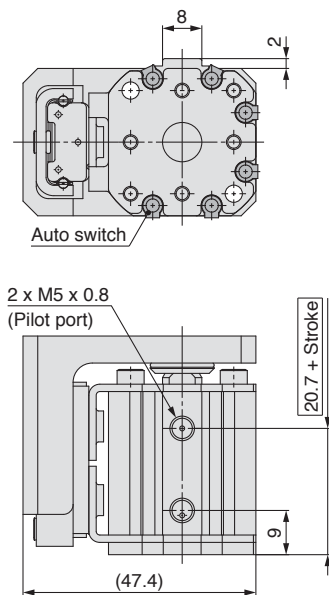

MXZ20R-□ (Pilot port location: Right)

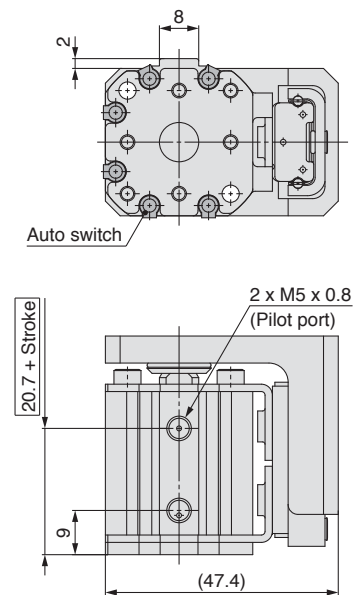



Dimensions: MXZ25

MXZ25-□ Standard (Pilot port location: Front)

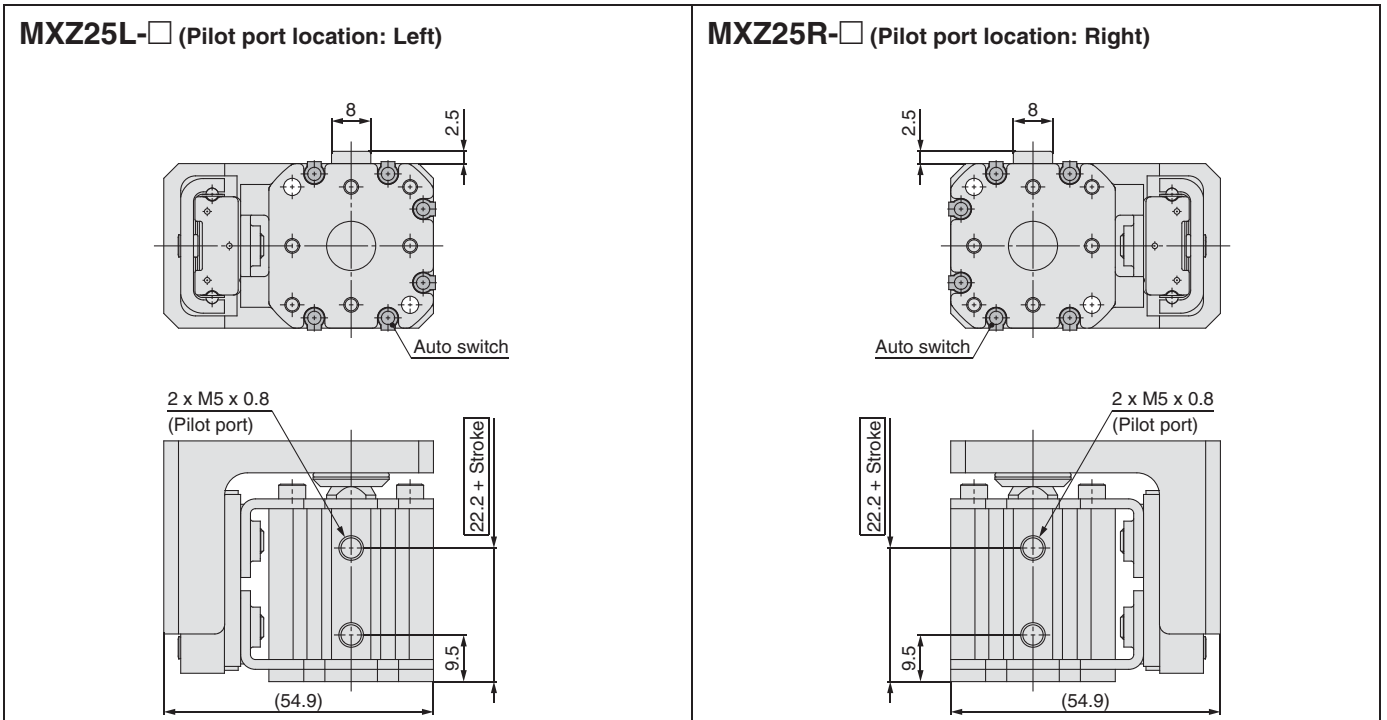
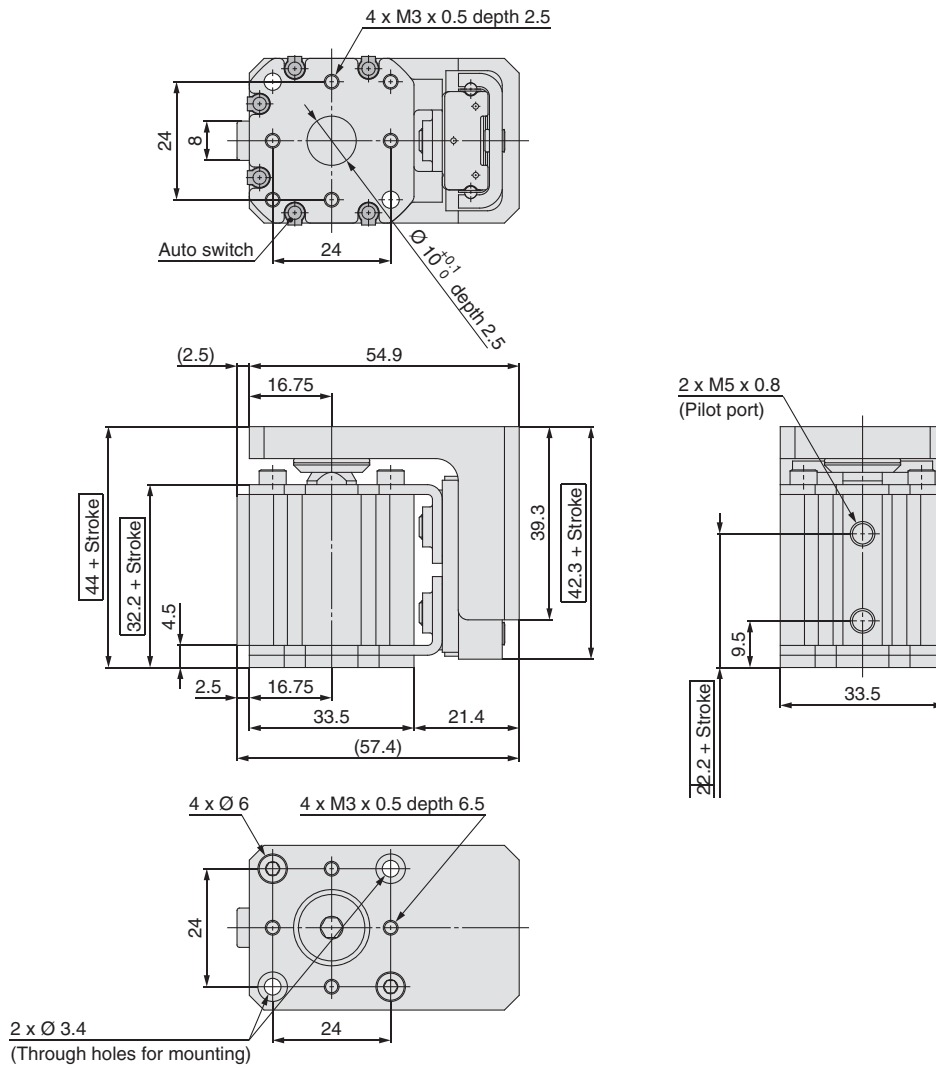

MXZ Series Model Selection

For Transfer

- (1) Load weight and overhang L_1 and L_2 , should be within the average speed limit in the graphs.
- (2) For horizontal use, overhang L_3 should not exceed the allowable range.
For vertical use, it is not necessary to consider L_3 as it does not affect the moment.

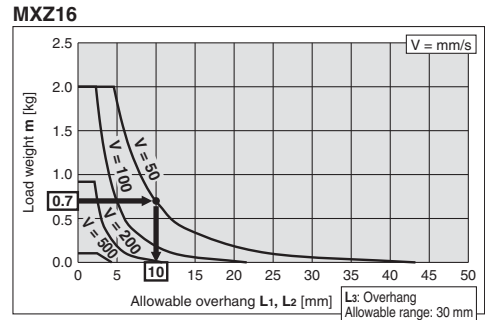
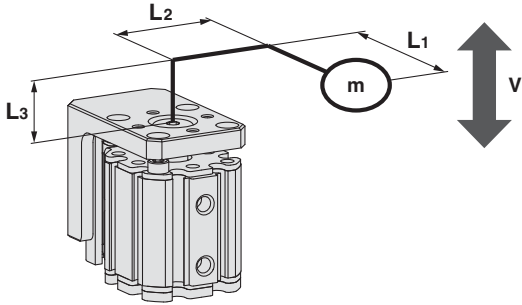

⚠ Caution

If the operating speed is increased after setting the operating conditions such as overhang and operating speed, the stopping impact force will increase which causes an excessive moment to be generated; this will lead to the failure of the guide. Do not increase the operating speed after setting the operating conditions.

If the adjusting screw of the speed controller is loosened, the operating speed will increase, so the screw should be tightened completely.

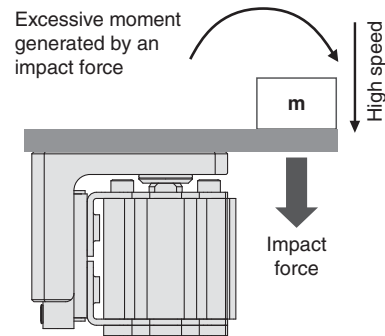

MXZ12

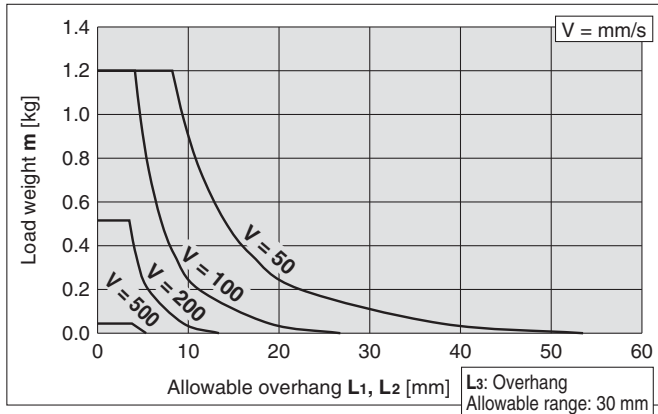

MXZ16

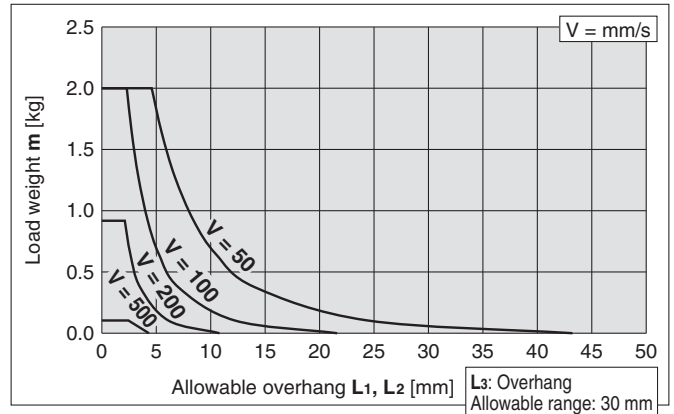

MXZ20

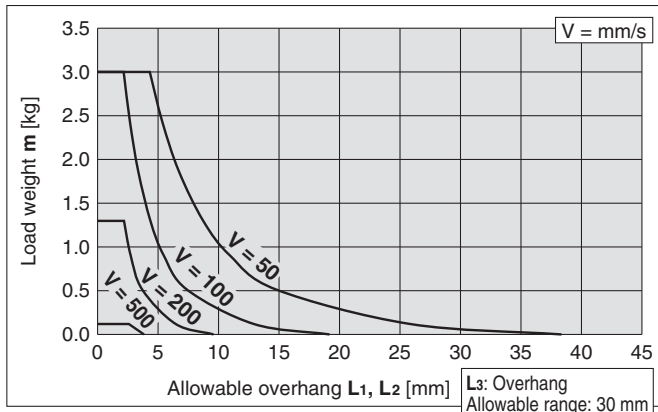

MXZ25

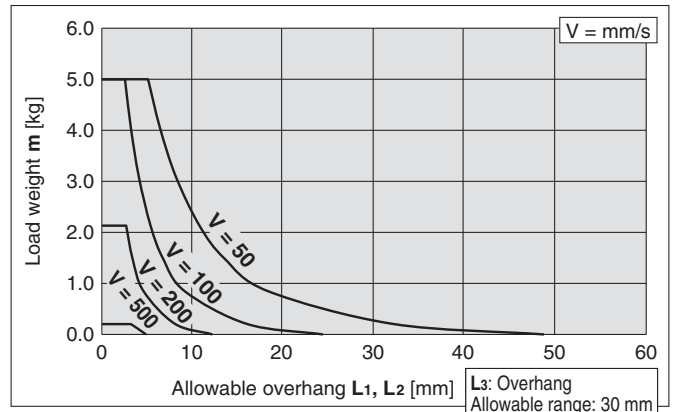

For Pressing (Clamping)

- (1) Confirm that the clamping jig weight and overhang are within the allowable range as shown in the graphs for transfer. (▶ **P. 11**)
- (2) Pressing force F and overhang L_1 should be within the range as shown in the graphs.

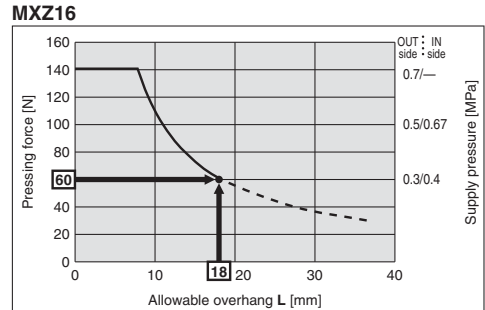
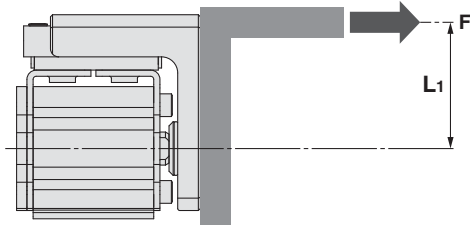

* Allowable supply pressure on OUT side and IN side is the theoretical output of cylinder when pressing force is required.

Caution

Pressing work should be performed in line with the centre of the guide.
 If there is an offset in the L_2 direction, an eccentric load will be applied to the guide. In this case, pressing operations should not be performed.

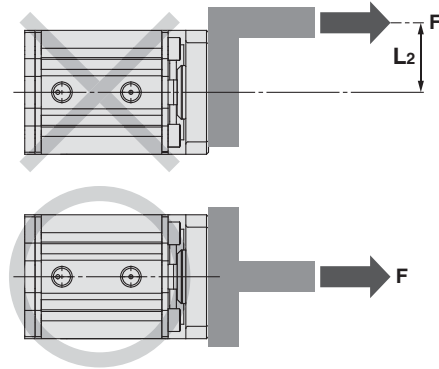

MXZ12

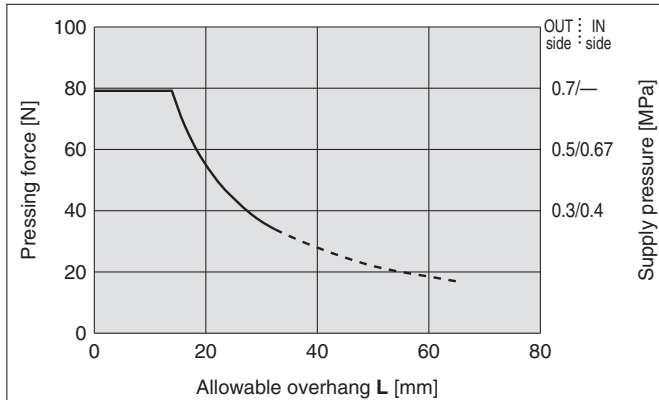

MXZ16

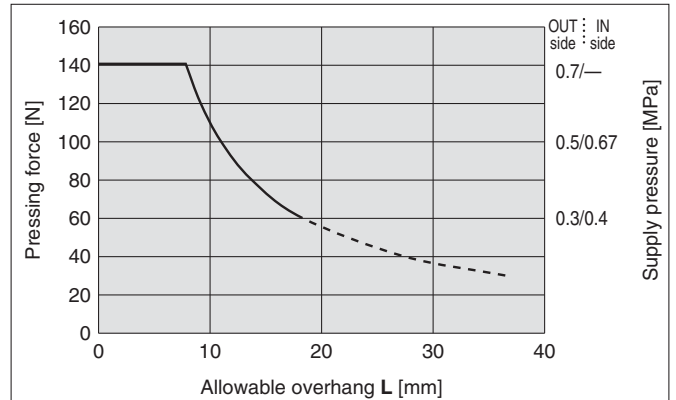

MXZ20

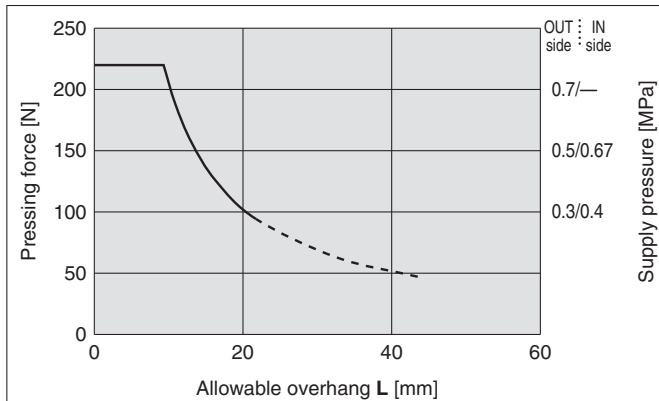

MXZ25

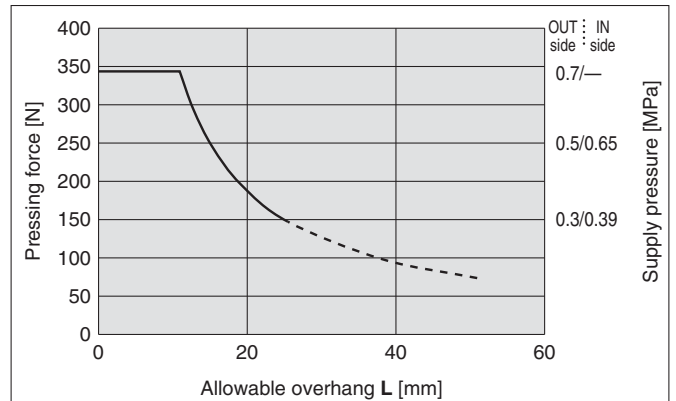

* Pressing force in the dotted line ranges are reference values as the pressing force may vary in these ranges.

MXZ Series

For Stopper

- (1) Confirm that the stopper jig weight and overhang are within the allowable range as shown in the graphs for transfer. (▶ P. 11)
- (2) The weight of a transferred object and transfer speed should be within the allowable range as shown in the graphs.
- (3) Overhang L_3 should be 30 mm or less.

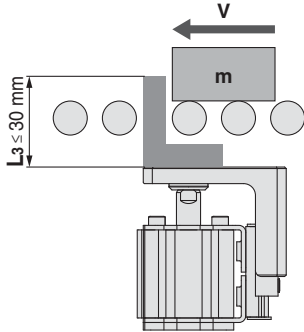

Caution

- (1) If a load is applied in the direction as shown on the right side, an eccentric load will be applied to the guide. In this case, the product should not be used as a stopper.

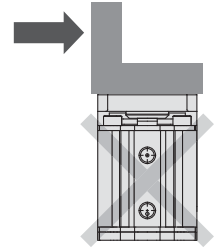

- (2) The transferred object should be stopped in line with the centre of the guide. If there is an offset in the L_2 direction, an eccentric load will be applied to the guide. In this case, this product should not be used as a stopper.

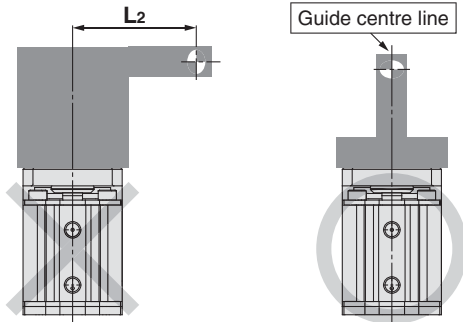

- (3) Place a bracket so that it contacts the machined corner of the surface for mounting or insert a pin into the through hole on the side to prevent sliding.

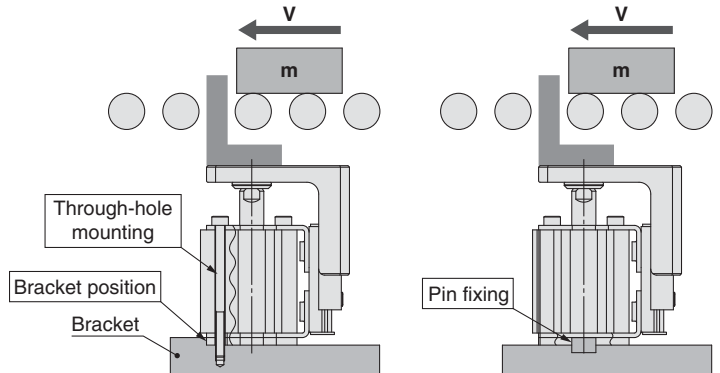

MXZ12

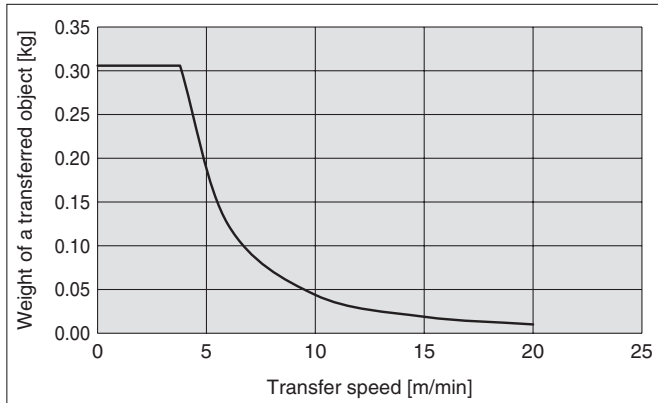

MXZ16

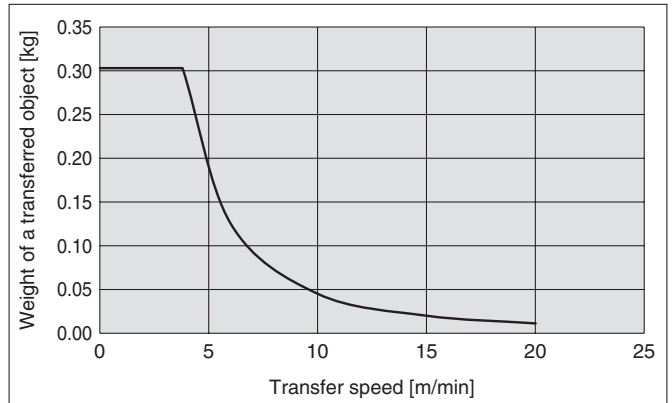

MXZ20

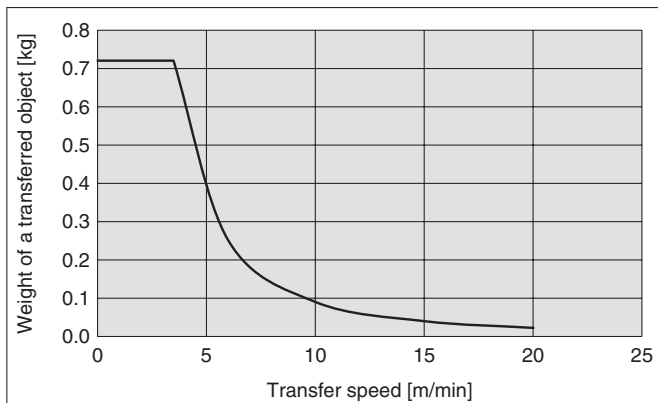

MXZ25

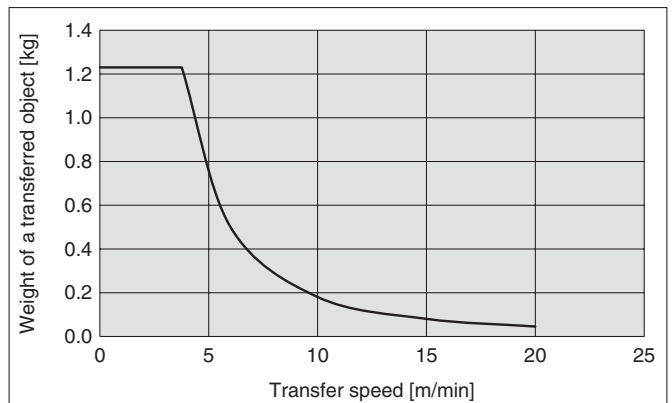
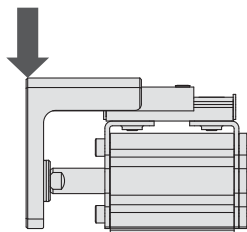

Table Deflection (Reference Values)

Table displacement due to pitch moment load

Displacement when a load is applied to the part indicated by the arrow for the entire stroke of the table



MXZ12

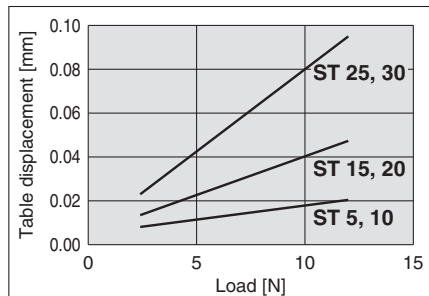

MXZ16

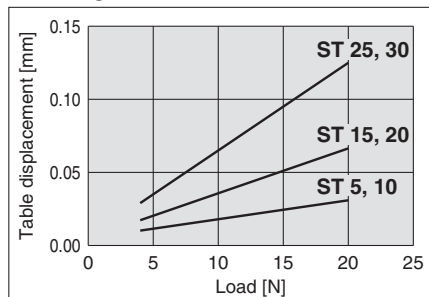

MXZ20

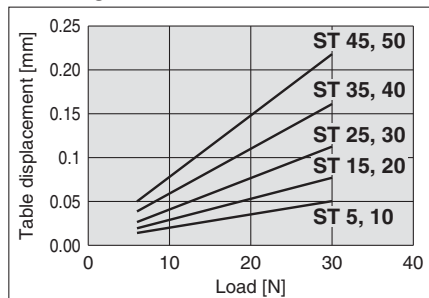

MXZ25

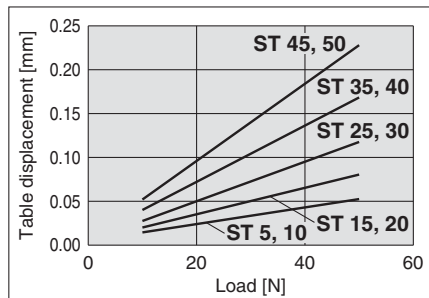
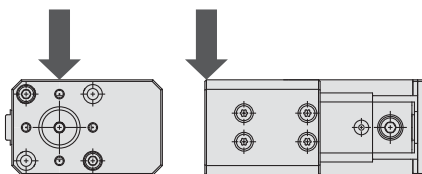
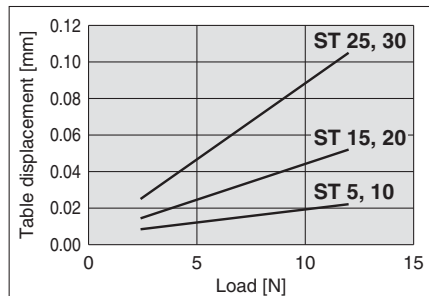

Table displacement due to yaw moment load

Displacement when a load is applied to the part indicated by the arrow for the entire stroke of the table



MXZ12



MXZ16

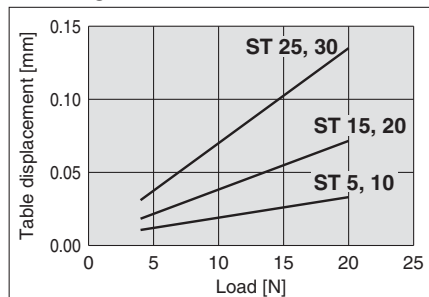

MXZ20

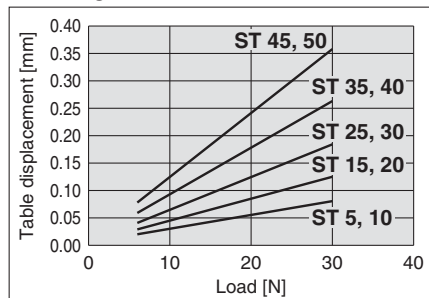

MXZ25

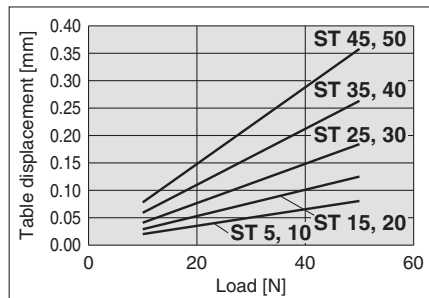
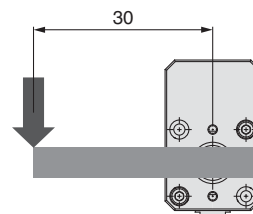
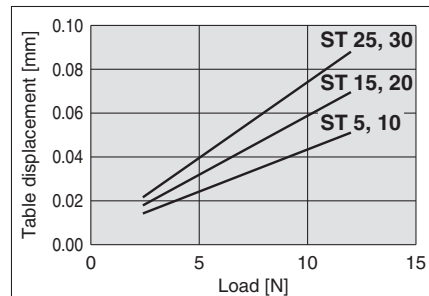

Table displacement due to roll moment load

Displacement when a load is applied to the part indicated by the arrow when the table is retracted



MXZ12



MXZ16

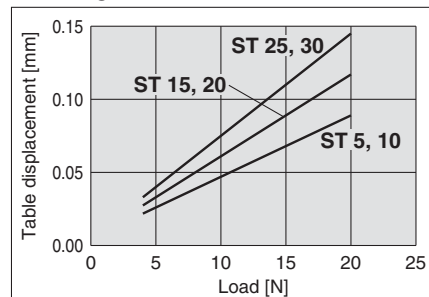

MXZ20

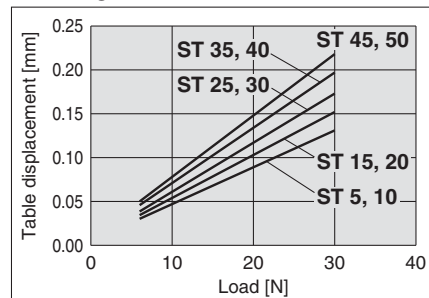

MXZ25

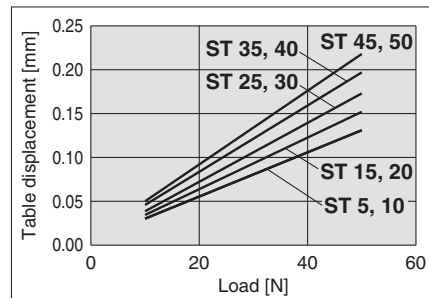

* ST = Stroke

MXZ Series Auto Switch Mounting

Minimum Stroke for Auto Switch Mounting

Auto switch model Mounting	[mm]			
	D-M9□V	D-M9□WV D-M9□AV	D-M9□	D-M9□W D-M9□A
(1) Bottom mounting	5	10*2	15*1	15*1
(2) When mounting an auto switch into the groove from the top*3	15	15	30	30
(3) Tube top mounting	5	10*2	5	10*2

*1 For 5 and 10 mm strokes, lead wires will interfere with mounting surface.

*2 For 5 mm stroke, it is possible to mount an auto switch, but 2-colour display may not be available.

*3 When mounting an auto switch from the top with 5 or 10 mm strokes, use a D-F8 auto switch.

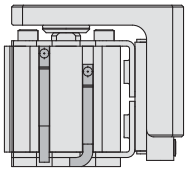

(1) Bottom mounting
(When mounting an auto switch before holding the product)

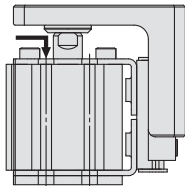

(2) When mounting an auto switch into the groove from the top
(When mounting an auto switch into the groove from the top after installation)

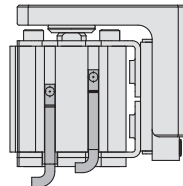

(3) Tube top mounting

Auto Switch Proper Mounting Position

Auto switch model Bore size	[mm]											
	D-M9□, D-M9□W			D-M9□V, D-M9□WV			D-M9□A			D-M9□AV		
	A	B	W	A	B	W	A	B	W	A	B	W
12	6.2	6.2	3.8	6.2	6.2	1.8	6.2	6.2	5.8	6.2	6.2	3.8
16	6.7	6.7	3.3	6.7	6.7	1.3	6.7	6.7	5.3	6.7	6.7	3.3
20	7.5	10	—	7.5	10	—	7.5	10	2	7.5	10	—
25	8	12	—	8	12	—	8	12	—	8	12	—

Auto Switch Mounting Height

Auto switch model Bore size	[mm]
	D-M9□V, D-M9□WV, D-M9□AV U
12	19.5
16	21
20	23
25	24.5

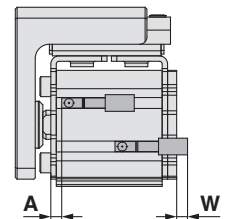
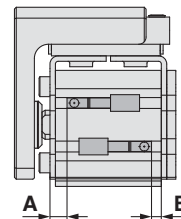
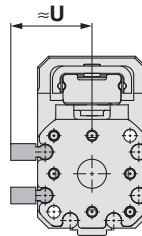

Operating Range

Auto switch model	[mm]			
	Applicable bore size			
	12	16	20	25
D-M9□(V)/M9□W(V)/M9□A(V)	3	3	4.5	4.5

* Values which include hysteresis are for guideline purposes only, they are not a guarantee and may change substantially depending on the ambient environment.

Auto Switch Mounting Groove Position

	MXZ12	MXZ16	MXZ20, 25
MXZ□□ (Pilot port on the front)	<p>Auto switch mounting groove</p> <p>Pilot port</p> <p>Linear guide</p> <p>Mounting on 2 surfaces</p>	<p>Pilot port</p> <p>Mounting on 2 surfaces</p>	<p>Pilot port</p> <p>Mounting on 3 surfaces</p>
MXZ□□R (Pilot port on the right)	<p>Pilot port</p> <p>Mounting on 1 surface</p>	<p>Pilot port</p> <p>Mounting on 1 surface</p>	<p>Pilot port</p> <p>Mounting on 3 surfaces</p>
MXZ□□L (Pilot port on the left)	<p>Pilot port</p> <p>Mounting on 1 surface</p>	<p>Pilot port</p> <p>Mounting on 1 surface</p>	<p>Pilot port</p> <p>Mounting on 3 surfaces</p>

Auto Switch Mounting

⚠ Caution

■ Auto Switch Mounting Tool

When tightening the auto switch mounting screw (included with auto switch), use a watchmaker's screwdriver with a gripping diameter of 5 to 6 mm.

■ Tightening Torque

Tightening Torque for Auto Switch Mounting Screw [N·m]

Auto switch model	Tightening torque
D-M9□(V)/M9□W(V)/M9□A(V)	0.05 to 0.15

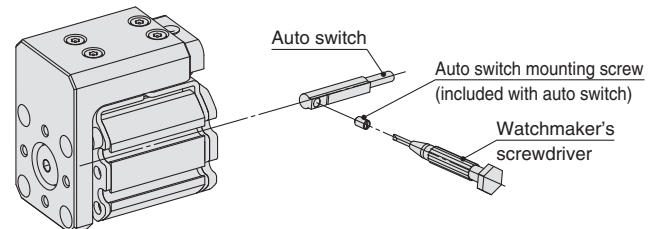

Other than the applicable auto switches listed in "How to Order", the following auto switches are mountable.

* Normally closed (NC = b contact) solid state auto switches (D-F9G/F9H) and solid state auto switch (D-F8) are also available. For details, refer to the Auto Switch Guide on our website www.smc.eu.



MXZ Series

Specific Product Precautions 1

Be sure to read this before handling the products. Refer to the back cover for safety instructions. For actuator and auto switch precautions, refer to the “Handling Precautions for SMC Products” and the “Operation Manual” on the SMC website: <http://www.smc.eu>

Mounting

Caution

1. Do not dent, scratch or cause other damage to the body, table and end plate mounting surfaces.

This may cause unevenness in the mounting surface, play in the guide or an increase in the sliding resistance.

2. Do not dent, scratch or cause other damage to the surface over which the rail and guide will move.

This may cause play or an increase in the sliding resistance.

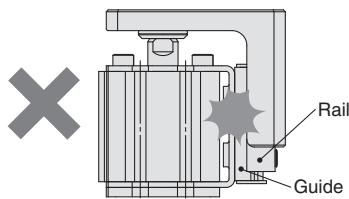

3. Do not apply strong impact or an excessive moment while mounting a workpiece.

If an external force over the allowable moment is applied, it may cause play in the guide or an increase in the sliding resistance.

4. Select the proper connection with the load which has external support and/or guide mechanism on the outside, and align it properly.

5. Do not attach magnets to the rail and guide unit.

Since the rail and guide are made of a magnetic substance, it could become magnetised if touched by a magnet etc. This could cause auto switch malfunction.

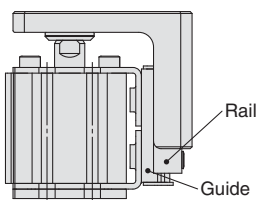

6. Do not remove the bolts holding the linear guide when removing the product. Incorrect handling of the product may cause mounting accuracy failure.

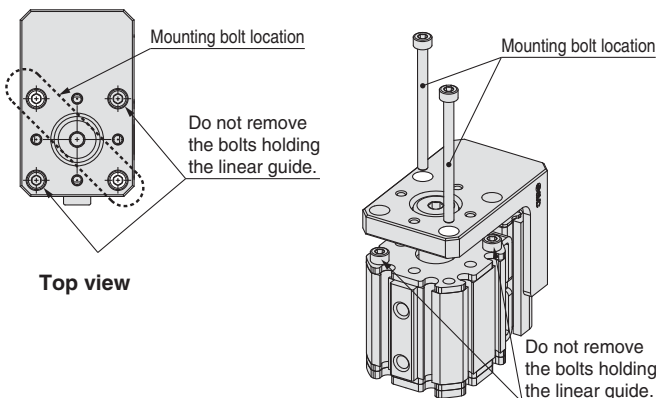

7. When mounting the product and a jig, tighten it with screws of appropriate length at an appropriate torque.

Tightening with a torque above the specified torque can cause malfunction, while insufficient tightening can cause slippage and dropping.

1. Tap Mounting

If bolts are too long, they will come into contact with the cylinder tube, in this case, the product will not be held correctly. Use bolts that are between the maximum and minimum screw-in depths in length.

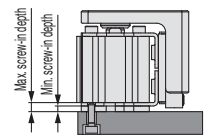

Model	Bolt	Tightening torque [N·m]	Min. screw-in depth [mm]	Max. screw-in depth [mm]
MXZ12	M3 x 0.5	0.63	2.5	3.4
MXZ16	M3 x 0.5			3.4
MXZ20	M3 x 0.5			3.7
MXZ25	M3 x 0.5			4.1

2. Through-hole Mounting

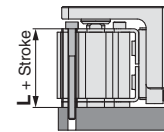

Model	Bolt	Tightening torque [N·m]	L [mm]
MXZ12	M3 x 0.5	0.63	24.5
MXZ16	M3 x 0.5		25.5
MXZ20	M3 x 0.5		29.7
MXZ25	M3 x 0.5		32.2

3. Mounting to the Table Using the Tapped Holes

1. If bolts are too long, they will come into contact with the bracket or flange during retraction, this will lead to the guide malfunction. Do not use bolts that are over the maximum screw-in depth in length.

2. When tightening the screws into the table surface, be careful to prevent applying a torque to the guide.

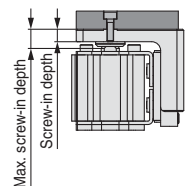

Model	Bolt	Tightening torque [N·m]	Screw-in depth [mm]	Max. screw-in depth [mm]
MXZ12	M3 x 0.5	0.63	5	6
MXZ16	M3 x 0.5		5	6
MXZ20	M3 x 0.5		5.5	6.3
MXZ25	M3 x 0.5		6.5	8.3



MXZ Series

Specific Product Precautions 2

Be sure to read this before handling the products. Refer to the back cover for safety instructions. For actuator and auto switch precautions, refer to the “Handling Precautions for SMC Products” and the “Operation Manual” on the SMC website: <http://www.smc.eu>

Operating Environment

⚠ Caution

1. Do not use in the environment, where the product could be exposed to the liquid such as cutting oil etc.

Using in the environment where the product could be exposed to cutting oil, coolant or oil mist, etc., could result in looseness, increased sliding resistance, or air leakage, etc.

2. Do not use in the environment, where the product could be exposed directly to the foreign matter such as powder dust, blown dust, cutting chip, spatter, etc.

This could result in looseness, increased sliding resistance, air leakage, etc. Please consult with SMC regarding use in this kind of environment.

3. Do not use in direct sunlight.

4. When there are heat sources in the surrounding area, block them off.

When there are heat sources in the surrounding area, radiated heat may cause the product's temperature to rise and exceed the operating temperature range. Block off the heat with a cover etc.

5. Do not subject it to excessive vibration and/or impact.

Please consult with SMC regarding use in this kind of environment, as this can cause damage and malfunction. Sufficient strength is secured for the table, but when it is damaged, never touch it with bare hands as the broken section and the fragments will be like a sharp-edged tool.

6. Use caution for the anti-corrosiveness of linear guide section.

Martensitic stainless steel is used for the table and guide block. But, use caution that anti-corrosiveness is inferior to the austenitic stainless steel. Especially, rust may be generated in an environment where water drops are likely to adhere due to condensation etc.

Others

⚠ Warning

1. Do not place your hands or fingers between the table and the bracket.

Hands or fingers could get caught between the table and the bracket when the piston rod retracts. If hands or fingers are caught, it can lead to injury.

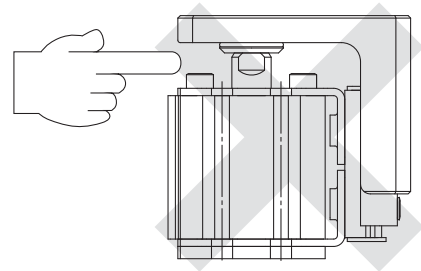

⚠ Caution

1. Do not disassemble and modify the product.

2. If the cylinder is stopped at an intermediate position by external stopper, position of the steel balls that make up the liner guide may become displaced.

When the intermediate stop is released while the steel ball position is displaced, the cylinder may not be able to achieve a full stroke with minimum operating pressure.

In this case, increase the supply pressure once up to the full stroke, then use the cylinder with the specified pressure.



3. Performance stability

The piston speed in the specification table shows the average speed. The actual speed of this product may vary slightly during the stroke depending on the operating conditions such as the change of load resistance and pressure.

If a stable operation at low speed is necessary, please consult local SMC sales office.

Safety Instructions

These safety instructions are intended to prevent hazardous situations and/or equipment damage. These instructions indicate the level of potential hazard with the labels of “Caution,” “Warning” or “Danger.” They are all important notes for safety and must be followed in addition to International Standards (ISO/IEC)*1), and other safety regulations.

-  **Caution:** Caution indicates a hazard with a low level of risk which, if not avoided, could result in minor or moderate injury.
-  **Warning:** Warning indicates a hazard with a medium level of risk which, if not avoided, could result in death or serious injury.
-  **Danger:** Danger indicates a hazard with a high level of risk which, if not avoided, will result in death or serious injury.

- *1) ISO 4414: Pneumatic fluid power – General rules relating to systems.
- ISO 4413: Hydraulic fluid power – General rules relating to systems.
- IEC 60204-1: Safety of machinery – Electrical equipment of machines. (Part 1: General requirements)
- ISO 10218-1: Manipulating industrial robots - Safety. etc.

Warning

- 1. The compatibility of the product is the responsibility of the person who designs the equipment or decides its specifications.**
Since the product specified here is used under various operating conditions, its compatibility with specific equipment must be decided by the person who designs the equipment or decides its specifications based on necessary analysis and test results. The expected performance and safety assurance of the equipment will be the responsibility of the person who has determined its compatibility with the product. This person should also continuously review all specifications of the product referring to its latest catalogue information, with a view to giving due consideration to any possibility of equipment failure when configuring the equipment.
- 2. Only personnel with appropriate training should operate machinery and equipment.**
The product specified here may become unsafe if handled incorrectly. The assembly, operation and maintenance of machines or equipment including our products must be performed by an operator who is appropriately trained and experienced.
- 3. Do not service or attempt to remove product and machinery/equipment until safety is confirmed.**
 1. The inspection and maintenance of machinery/equipment should only be performed after measures to prevent falling or runaway of the driven objects have been confirmed.
 2. When the product is to be removed, confirm that the safety measures as mentioned above are implemented and the power from any appropriate source is cut, and read and understand the specific product precautions of all relevant products carefully.
 3. Before machinery/equipment is restarted, take measures to prevent unexpected operation and malfunction.
- 4. Contact SMC beforehand and take special consideration of safety measures if the product is to be used in any of the following conditions.**
 1. Conditions and environments outside of the given specifications, or use outdoors or in a place exposed to direct sunlight.
 2. Installation on equipment in conjunction with atomic energy, railways, air navigation, space, shipping, vehicles, military, medical treatment, combustion and recreation, or equipment in contact with food and beverages, emergency stop circuits, clutch and brake circuits in press applications, safety equipment or other applications unsuitable for the standard specifications described in the product catalogue.
 3. An application which could have negative effects on people, property, or animals requiring special safety analysis.
 4. Use in an interlock circuit, which requires the provision of double interlock for possible failure by using a mechanical protective function, and periodical checks to confirm proper operation.

Limited warranty and Disclaimer/ Compliance Requirements

The product used is subject to the following “Limited warranty and Disclaimer” and “Compliance Requirements”.
Read and accept them before using the product.

Limited warranty and Disclaimer

1. The warranty period of the product is 1 year in service or 1.5 years after the product is delivered, whichever is first.*2)
Also, the product may have specified durability, running distance or replacement parts. Please consult your nearest sales branch.
2. For any failure or damage reported within the warranty period which is clearly our responsibility, a replacement product or necessary parts will be provided. This limited warranty applies only to our product independently, and not to any other damage incurred due to the failure of the product.
3. Prior to using SMC products, please read and understand the warranty terms and disclaimers noted in the specified catalogue for the particular products.

*2) Vacuum pads are excluded from this 1 year warranty.

A vacuum pad is a consumable part, so it is warranted for a year after it is delivered. Also, even within the warranty period, the wear of a product due to the use of the vacuum pad or failure due to the deterioration of rubber material are not covered by the limited warranty.

Compliance Requirements

1. The use of SMC products with production equipment for the manufacture of weapons of mass destruction (WMD) or any other weapon is strictly prohibited.
2. The exports of SMC products or technology from one country to another are governed by the relevant security laws and regulations of the countries involved in the transaction. Prior to the shipment of a SMC product to another country, assure that all local rules governing that export are known and followed.

Caution

- 1. The product is provided for use in manufacturing industries.**
The product herein described is basically provided for peaceful use in manufacturing industries.
If considering using the product in other industries, consult SMC beforehand and exchange specifications or a contract if necessary.
If anything is unclear, contact your nearest sales branch.

Caution

SMC products are not intended for use as instruments for legal metrology.
Measurement instruments that SMC manufactures or sells have not been qualified by type approval tests relevant to the metrology (measurement) laws of each country. Therefore, SMC products cannot be used for business or certification ordained by the metrology (measurement) laws of each country.

Safety Instructions

Be sure to read “Handling Precautions for SMC Products” (M-E03-3) before using.

SMC Corporation (Europe)

Austria	☎ +43 (0)2262622800	www.smc.at	office@smc.at	Lithuania	☎ +370 5 2308118	www.smclt.lt	info@smclt.lt
Belgium	☎ +32 (0)33551464	www.smcpnematics.be	info@smcpneumatics.be	Netherlands	☎ +31 (0)205318888	www.smcpnematics.nl	info@smcpneumatics.nl
Bulgaria	☎ +359 (0)2807670	www.smc.bg	office@smc.bg	Norway	☎ +47 67129020	www.smc-norge.no	post@smc-norge.no
Croatia	☎ +385 (0)13707288	www.smc.hr	office@smc.hr	Poland	☎ +48 222119600	www.smc.pl	office@smc.pl
Czech Republic	☎ +420 541424611	www.smc.cz	office@smc.cz	Portugal	☎ +351 226166570	www.smc.eu	postpt@smc.smces.es
Denmark	☎ +45 70252900	www.smcdk.com	smc@smcdk.com	Romania	☎ +40 213205111	www.smcromania.ro	smcromania@smcromania.ro
Estonia	☎ +372 6510370	www.smcpnematics.ee	smc@smcpneumatics.ee	Russia	☎ +7 8127185445	www.smc-pneumatik.ru	info@smc-pneumatik.ru
Finland	☎ +358 207513513	www.smc.fi	smc@smc.fi	Slovakia	☎ +421 (0)413213212	www.smc.sk	office@smc.sk
France	☎ +33 (0)164761000	www.smc-france.fr	info@smc-france.fr	Slovenia	☎ +386 (0)73885412	www.smc.si	office@smc.si
Germany	☎ +49 (0)61034020	www.smc.de	info@smc.de	Spain	☎ +34 902184100	www.smc.eu	post@smc.smces.es
Greece	☎ +30 210 2717265	www.smchellas.gr	sales@smchellas.gr	Sweden	☎ +46 (0)86031200	www.smc.nu	post@smc.nu
Hungary	☎ +36 23511390	www.smc.hu	office@smc.hu	Switzerland	☎ +41 (0)523963131	www.smc.ch	info@smc.ch
Ireland	☎ +353 (0)14039000	www.smcpnematics.ie	sales@smcpneumatics.ie	Turkey	☎ +90 212 489 0 440	www.smcpnomatik.com.tr	info@smcpnomatik.com.tr
Italy	☎ +39 0292711	www.smcitalia.it	mailbox@smcitalia.it	UK	☎ +44 (0)845 121 5122	www.smcpnematics.co.uk	sales@smcpneumatics.co.uk
Latvia	☎ +371 67817700	www.smc.lv	info@smclv.lv				

SMC CORPORATION Akihbara UDX 15F, 4-14-1, Sotokanda, Chiyoda-ku, Tokyo 101-0021, JAPAN Phone: 03-5207-8249 FAX: 03-5298-5362